

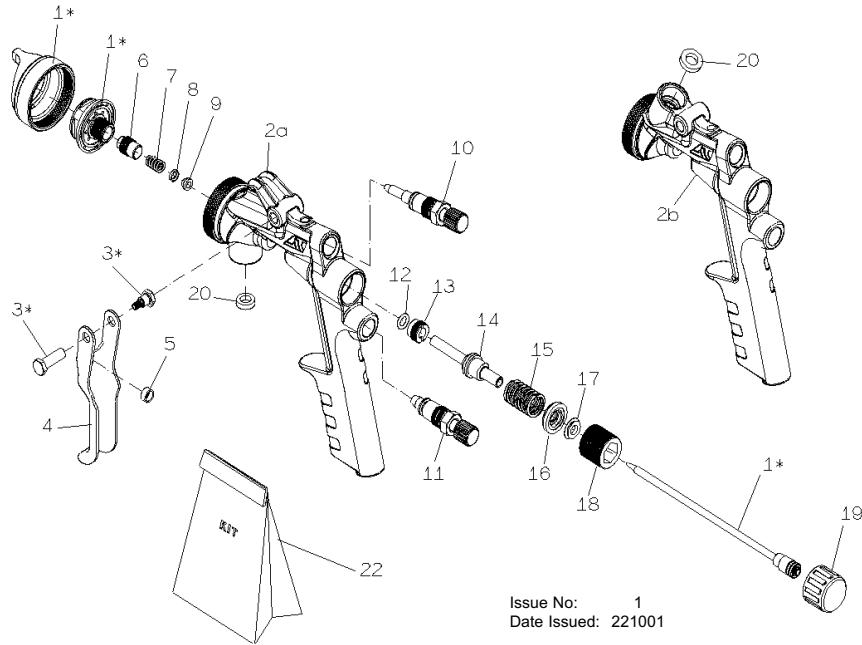

PARTS FOR:
HVLP SPRAY GUNS

Models: HVLP-750.V2 & HVLP-751.V2



Issue No: 1
Date Issued: 221001

| Item | Part No. | Description | Item | Part No. | Description |
|------|---------------|-----------------------------|------|--------------|-------------------------------|
| 1 | 142/BH0880186 | 1.3 Complete Nozzle | 10 | 142/BH088494 | Upper Complete Regulator |
| 1 | 142/BH0880187 | 1.5 Complete Nozzle | 11 | 142/BH088506 | Lower Complete Regulator |
| 1 | 142/BH0880188 | 1.7 Complete Nozzle | 12 | 142/BD088082 | O-Ring 2025 PTFE |
| 1 | 142/BH0880189 | 1.9 Complete Nozzle | 13 | 142/BS088084 | Piston Gland |
| 2a | 142/BH0880190 | Complete Body - HVLP-750.V2 | 14 | 142/BH088165 | Complete Piston |
| 2b | 142/BH0880191 | Complete Body - HVLP-751.V2 | 15 | 142/BA108014 | Spring |
| 3 | 142/BF088632 | Rivet, 6 x 26.5 Zinc Plated | 16 | 142/BS088085 | Washer |
| 4 | 142/BL089617 | Trigger | 17 | 142/BD088086 | O-Ring FC 2025 |
| 5 | 142/BS088450 | Piston Guard | 18 | 142/BS088118 | Sleeve |
| 6 | 142/BS088775 | Packing Gland | 19 | 142/BI088114 | Needle Ring Nut |
| 7 | 142/BA088773 | Spring Gland | 20 | 142/BE088732 | 1/4" Cup Gasket - HVLP-750.V2 |
| 8 | 142/BS088774 | Washer Gland | 20 | 142/BC088081 | 3/8" Cup Gasket - HVLP-751.V2 |
| 9 | 142/BC088765 | Gasket | 22 | 142/BH138010 | Service Kit |

NOTE: It is our policy to continually improve products and as such we reserve the right to alter data, specifications and component parts without prior notice.
IMPORTANT: No responsibility is accepted for incorrect use of this product.
WARRANTY: Guarantee is 12 months from purchase date, proof of which will be required for any claim.
INFORMATION: For a copy of our latest catalogue and promotions call 01284 757525 and leave your name and address, including postcode.

Sole UK Distributor,
Sealey Group,
 Bury St. Edmunds, Suffolk.

01284 757500

01284 703534

E-mail: sales@sealey.co.uk



INSTRUCTIONS FOR:
HVLP SPRAY GUNS

Models: HVLP-750.V2 & HVLP-751.V2

Thank you for purchasing a Sealey product. Manufactured to a high standard this product will, if used according to these instructions and properly maintained, give you years of trouble free performance.

IMPORTANT: PLEASE READ THESE INSTRUCTIONS CAREFULLY. NOTE THE SAFE OPERATIONAL REQUIREMENTS, WARNINGS AND CAUTIONS. USE THIS PRODUCT CORRECTLY AND WITH CARE FOR THE PURPOSE FOR WHICH IT IS INTENDED. FAILURE TO DO SO MAY CAUSE DAMAGE AND/OR PERSONAL INJURY AND WILL INVALIDATE THE WARRANTY. PLEASE KEEP INSTRUCTIONS SAFE FOR FUTURE USE.

1. SAFETY INSTRUCTIONS

- Familiarise yourself with the application, limitations and potential hazards peculiar to the spray gun.
 - WARNING!** Disconnect the spray gun from the air supply before changing accessories, servicing or performing any maintenance.
- Maintain the spray gun in good condition (use an authorised service agent).
- Replace or repair damaged parts. *Use recommended parts only. Unauthorised parts may be dangerous and will invalidate the warranty.*
- Keep the spray gun clean for best and safest performance.
- Ensure that the compressed air system can supply the spray gun air consumption (550l/min - 19.4cfm).
- Wear approved safety respiratory protection and safety eye goggles.
- If spraying isocyanate based finisher, wear approved respirator/clean air breathing apparatus and cover exposed skin with latex gloves and an impervious hooded coverall.
- Remove ill fitting clothing. Remove ties, watches, rings and other loose jewellery and tie back long hair.
- Locate the spray gun in a suitable work area. Keep area clean and tidy and free from unrelated materials and ensure that there is adequate ventilation and lighting.
- Keep children and unauthorised persons away from the work area.
- When not in use, ensure that the air supply is turned off.
- Avoid unintentional operation of spray gun.
- DO NOT point spray gun at yourself, other persons or animals.
- DO NOT direct air from the air hose at yourself, other persons or animals.
- DO NOT carry the spray gun by the hose, or yank the hose from the air supply.
- DO NOT exceed the maximum air pressure of 58psi (4 bar).
- DO NOT use the spray gun for any purpose other than that for which it is designed.
- DO NOT allow untrained persons to operate the spray gun.
- DO NOT get the spray gun wet or use in damp or wet locations or in areas where there is condensation.
- DO NOT operate the spray gun if any parts are missing or damaged as this may cause failure and/or personal injury.
- When not in use, disconnect the spray gun from the air supply, clean thoroughly and store safely.

2. DESCRIPTION & SPECIFICATIONS

The HVLP spray gun has an anodised body which resists corrosion and has a low affinity for paint, making this unit easy to clean. The gun also has adjustable paint and fan width controls. HVLP (High Volume, Low Pressure) uses lower air pressure but at a far higher throughput. The result of this is that very much more of the paint stays on the panel and less disappears into the atmosphere.

SPECIFICATIONS

Model HVLP-750.V2 Suction Feed

Standard set-up1.7mm
 Available set-ups1.3, 1.5, 1.9mm
 Working pressure range .29 - 37.7psi (2 - 2.6 bar)
 Max. safe pressure58psi (4 bar)
 Air consumption . .14.6 - 19.4cfm (414 - 550l/min)

Model HVLP-751.V2 Gravity Feed

Standard set-up1.5mm
 Available set-ups1.3, 1.7, 1.9mm
 Working pressure range .29 - 37.7psi (2 - 2.6 bar)
 Max. safe pressure58psi (4 bar)
 Air consumption . .14.6 - 19.4cfm (414 - 550l/min)

3. AIR SUPPLY

Recommended supply system is shown below.

- 3.1. Ensure that the spray gun trigger is in the "off" position before connecting to the air supply.
- 3.2. You will require an air pressure between 30 and 40psi, and an air flow according to the specification.

WARNING! Ensure that the air supply is clean and does not exceed 58psi while operating the spray gun. Too high an air pressure and/or unclean air will shorten the product life, due to excessive wear, and may cause damage and/or personal injury.
- 3.3. Drain the air tank daily. Water in the air line will damage the spray gun and **invalidate your warranty**.
- 3.4. Clean compressor air inlet filter weekly.
- 3.5. Line pressure should be increased to compensate for unusually long air hoses (over 8 metres).
 The minimum hose diameter should be 1/4" I.D. and fittings must have the same inside dimensions.
- 3.6. Keep hose away from heat, oil and sharp edges. Check hoses for wear, and make certain that all connections are secure.

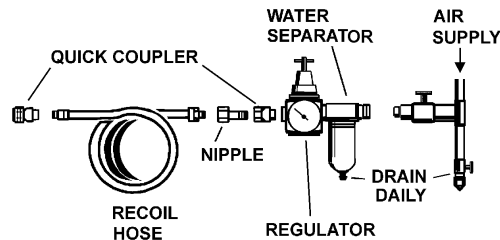

4. OPERATING INSTRUCTIONS

- 4.1. For best results, handle the gun correctly. It should be held perpendicular to the surface being sprayed and moved parallel to it. Start the stroke before squeezing the trigger and release the trigger before finishing the stroke. This will give more accurate control of the gun and the material (see right).
- 4.2. Spray from a distance of 6 to 10 inches, depending on the material and the atomizing pressure. The material deposited should always be even and wet. Each stroke must overlap the preceding stroke to obtain a uniform finish. To reduce over-spray and obtain maximum efficiency, spray with the lowest possible atomizing air pressure.
- 4.3. Controlling the fluid and the fan spray:
 - a) As the width of the spray is altered so the fluid flow must be adjusted to maintain the same coverage. Use the fluid control screw ('C' in Section 6).
 - c) The direction of the fan spray, either horizontal or vertical, is adjusted by turning the air nozzle to the desired position and then tightening the retaining ring.

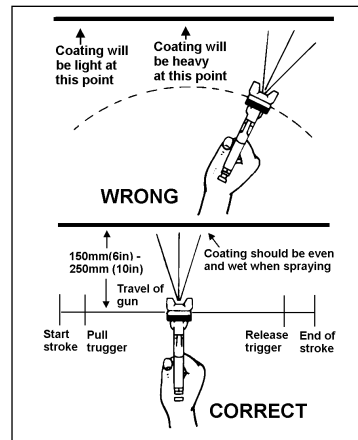

5. MAINTENANCE & CLEANING

Disconnect from the air supply before attempting any maintenance or cleaning. When reassembling after maintenance, be sure to take care when screwing parts together. At first screw parts hand tight to avoid cross-threading. If a part cannot easily be turned by hand, check that you have the correct part, or unscrew, realign and try again. **DO NOT** use excessive force when reassembling.

- 5.1. **Spray gun**
 - 5.1.1. Immerse the *front end of the gun only* in solvent until the solvent just covers the fluid connection.
 - 5.1.2. Use a bristle brush and solvent to wash off accumulated paint.



- 5.1.3. Do not immerse the entire gun in solvent. This will cause lubricants to dissolve and packing to dry out. Dirty solvent may also clog the narrow passages in the gun.
- 5.1.4. Wipe the outside of the gun with a dampened solvent rag.
- 5.1.5. Lubricate the gun daily with a light machine oil. Be sure to lubricate the fluid needle packing, air valve packing, side port control packing and trigger pivot point. Do not use lubricants containing silicone.
- 5.1.6. When finished spraying, flush the gun through with clean thinners.
- 5.2. **Air nozzle, fluid nozzle and needle assembly**
 - 5.2.1. To clean the nozzles, soak them in solvent to dissolve any dried material then blow them clean with air. Handle all nozzles carefully and do not make any alterations in the gun.
 - 5.2.2. If you need to probe the holes in the nozzles, be sure to use a tool that is softer than brass; do not use metal instruments.
 - 5.2.3. Adjust the fluid needle valve so that when the gun is triggered, air flow occurs before fluid flow.

6. TROUBLESHOOTING

| THE PROBLEM | THE CAUSE | THE SOLUTION |
|--|---|--|
| Poor atomization/heavy centre pattern | Fluid flow is too high for the air pressure and flow | <ol style="list-style-type: none"> 1. Increase air pressure by adjusting regulator (A) and increase flow adjusting regulator (B). 2. Reduce paint flow with regulator (C). 3. Paint may be too thick. If so, dilute it. |
| Heavy atomization, poor centre pattern | Air pressure and flow too high for fluid flow | <ol style="list-style-type: none"> 1. Reduce air pressure by adjusting regulator (A). 2. Reduce air flow by adjusting regulator (B) and increase fluid flow with regulator (C). |
| Intermittent spray pattern | Air entering the fluid supply | <ol style="list-style-type: none"> 1. Tighten the connection between the gun and the cup. 2. Tighten fluid nozzle with gun spanner. 3. Check if cup vent hole is blocked. 4. Check if cup is empty. |
| Heavy right or left side pattern | Horn hole (A) blocked. In order to check, turn the air cap 180°, if the faulty pattern is now upside down the hole must be cleaned. | <ol style="list-style-type: none"> 1. Place the air cap in solvent. 2. Clean hole with compressed air or with a wooden toothpick. DO NOT use a metal probe which will damage the hole. |
| Top heavy or bottom heavy pattern | Possible paint build-up between fluid nozzle and air cap (A). | <ol style="list-style-type: none"> 1. Clean the air cap and the fluid nozzle, check that they match. 2. Check needle for damage. |

7. DECLARATION OF CONFORMITY

Declaration of Conformity We, the sole importer into the UK, declare that the products listed here are in conformity with the following standards and directives.

Spray Guns
Models HVLP-750.V2 & HVLP-751.V2
 97/23/EC Pressure Equipment Directive
 93/68/EEC CE Marking Directive



The construction files for these products are held by the manufacturer and may be inspected, by a national authority, upon request to Jack Sealey Ltd.

Signed by Mark Sweetman

For Jack Sealey Ltd. Sole importer into the UK of Sealey Power Products.

22nd October 2001