

Thank you for purchasing a Sealey product. Manufactured to a high standard this product will, if used according to these instructions and properly maintained, give you years of trouble free performance.



**IMPORTANT: PLEASE READ THESE INSTRUCTIONS CAREFULLY. NOTE THE SAFE OPERATIONAL REQUIREMENTS, WARNINGS AND CAUTIONS. USE THE PRODUCT CORRECTLY AND WITH CARE FOR THE PURPOSE FOR WHICH IT IS INTENDED. FAILURE TO DO SO MAY CAUSE DAMAGE OR PERSONAL INJURY, AND WILL INVALIDATE THE WARRANTY. PLEASE KEEP INSTRUCTIONS SAFE FOR FUTURE USE.**

### 1. SAFETY INSTRUCTIONS

#### 1.1. ELECTRICAL SAFETY. **WARNING!** It is the user's responsibility to read, understand and comply with the following:

You must check all electrical equipment and appliances to ensure they are safe before using. You must inspect power supply leads, plugs and all electrical connections for wear and damage. You must ensure the risk of electric shock is minimised by the installation of appropriate safety devices. An RCCB (Residual Current Circuit Breaker) should be incorporated in the main distribution board. We also recommend that an RCD (Residual Current Device) is used with all electrical products. It is particularly important to use an RCD together with portable products that are plugged into an electrical supply not protected by an RCCB. If in doubt consult a professional electrician. You may obtain a Residual Current Device by contacting your Sealey dealer. **You must** also read and understand the following instructions concerning electrical safety.

- 1.1.1. The **Electricity At Work Act 1989** requires all portable electrical appliances, if used on a business premises, to be tested by a qualified Electrician at least once a year by using a Portable Appliance Tester (PAT).
- 1.1.2. The **Health & Safety at Work Act 1974** makes owners of electrical appliances responsible for the safe condition of the appliance, and the safety of the appliance operator. **If in doubt about electrical safety, contact a qualified electrician.**
- 1.1.3. Ensure the insulation on all cables and the product itself is safe before connecting to the mains power supply. See 1.1.1. & 1.1.2. above and use a Portable Appliance Tester (PAT).
- 1.1.4. Ensure that cables are always protected against short circuit and overload.
- 1.1.5. Regularly inspect power supply, leads, plugs and all electrical connections for wear and damage, especially power connections, to ensure that none are loose.
- 1.1.6. **Important:** Ensure the voltage marked on the product is the same as the electrical power supply to be used, and check that plugs are fitted with the correct capacity fuse. See fuse rating at right.
- 1.1.7. DO NOT pull or carry the powered appliance by its power supply lead.
- 1.1.8. DO NOT pull power plugs from sockets by the power cable.
- 1.1.9. DO NOT use worn or damaged leads, plugs or connections. Immediately replace or have repaired by a qualified Electrician. A U.K. 3 pin plug with ASTA/BS approval is fitted. In case of damage, cut off and fit a new plug according to the following instructions (discard old plug safely). (UK only - see diagram at right). **Ensure the unit is correctly earthed via a three-pin plug.**
  - a) Connect the GREEN/YELLOW earth wire to the earth terminal 'E'.
  - b) Connect the BROWN live wire to live terminal 'L'.
  - c) Connect the BLUE neutral wire to the neutral terminal 'N'.

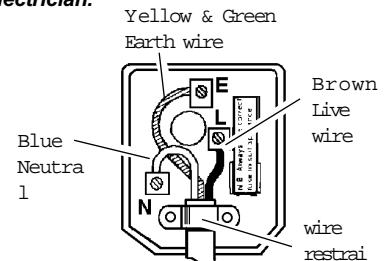

**THIS PRODUCT MUST BE FITTED WITH A: 3 AMP FUSE**

**After wiring, check there are no bare wires, that all wires have been correctly connected and that the wire restraint is tight.** Double insulated products are often fitted with live (BROWN) and neutral (BLUE) wires only. Double insulated products are always marked with this symbol To re-wire, connect the brown & blue wires as indicated above. **DO NOT** connect the brown or blue to the earth terminal.

- 1.1.10. Cable extension reels. DO NOT use an extension lead unless it has been approved by an electrical authority. When a cable extension reel is used it should be fully unwound before connection. A cable reel with an RCD fitted is recommended since any product which is plugged into the cable reel will be protected. The section of the cable on the cable reel is important. We recommend that at least 1.5mm<sup>2</sup> section cable but to be absolutely sure that the capacity of the cable reel is suitable for this product and for others that may be used in the other output sockets, we recommend the use of 2.5mm<sup>2</sup> section cable.

#### 1.2 GENERAL SAFETY

- 3 Disconnect the fan from the mains power when not in use, and before servicing or performing any maintenance.
- 3 Use the fan in dry areas only. Do not use in wet or area with high condensation such as showers, pools etc.
- 3 **WARNING!** If a fan falls into water or other liquid, immediately switch off and disconnect from the mains power supply. Do not touch the fan until the mains power supply has been disconnected.
- 3 Always disconnect the fan from the power supply when moving it from one location to another and ensure fan is stood on a level surface.
- 3 The fan air flow is powerful. Before using ensure there are no materials or items that may be erroneously moved by the stream of air.
- 3 Keep the fan clean and maintained in good condition. For electrical components or motor service contact an authorised service agent.
- 3 Use recommended parts only (non genuine parts may be dangerous, and will invalidate your warranty).
- 7 DO NOT operate the fan where there is harmful, explosive or flammable gases, fumes or hazardous substances.
- 7 DO NOT stand the fan on its electrical power cable.
- 7 DO NOT insert any objects through the fan guard.
- 7 DO NOT cover the fan when in use.
- 7 DO NOT immerse the fan in water or any other liquid.
- 7 DO NOT allow children to operate the fan.
- 7 DO NOT stand the fan where it may be knocked over or off a surface, or where the lead may cause a person to trip.
- 7 DO NOT use the fan outdoors.
- 7 DO NOT use an extension cord unless it has been approved by an electrical authority.
- 7 DO NOT modify speed control or attempt to fit any additional external speed control device to the fan.
- 3 When not in use place the fan in its original box or cover the fan to protect from dust, and store in a safe, dry, childproof location.

## 2. SPECIFICATIONS

### HVF14

Fan diameter 14"  
Power supply 230V  
Motor 70W 50Hz

### HVF18

Fan diameter 18"  
Power supply 230V  
Motor 170W 50Hz

## 3. ASSEMBLY & OPERATING

### 3.1. ASSEMBLY.

Unpack carton and assemble the fan as follows:

- 3.1.1. Remove the holding screw (fig 1.2) from the rear of the fan control box (1).
- 3.1.2. Push the fan control box fixing pin (4) through the hole in the right leg of the fan base (3).
- 3.1.3. Fix with the holding screw (2) and firmly tighten the fan control box onto the leg.  
NOTE: Ensure you install the control box with the power lead (5) running directly from the rear of the fan motor around the right leg to control box and not tucked under or through the base leg.

### 3.2. FAN OPERATION.

**WARNING! Ensure you read, understand and apply safety instructions before using fan.**

- 3.2.1. Use handle to carry the fan and place in a suitable location.
- 3.2.2. Check that the speed control box (1) is set to "0" (off), plug into the mains power supply and switch the power on.
- 3.2.3. The Fan has three speeds in order to meet various air circulation requirements. Settings "1" (Low) and "2" (Medium) should meet most workshop needs. For maximum output select speed "3".
- 3.2.4. Adjust the air stream by moving the base from side to side and tilting the fan up or down.
- 3.2.5. When you have finished using the fan ensure you turn the speed control switch to "0" (off) and disconnect the fan from mains power.

fig 1

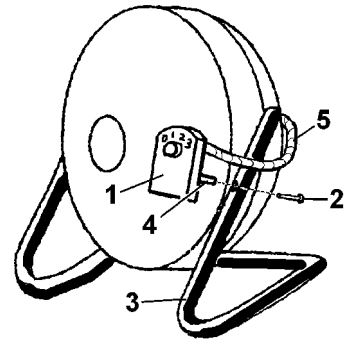

## 4. CARE OF FAN

**WARNING! Ensure the fan is disconnected from the mains power supply before attempting any of the following:**

- 4.1. Use a soft, damp cloth to clean the fan.  
DO NOT immerse the fan in water and never allow water to drip onto the motor housing.  
DO NOT use solvents, petroleum, paint thinner or other chemicals to clean the fan.
- 4.2. To clean the fan blade, use 2 screw drivers to disengage the hooks (fig 2.) which hold the front and back grills together. Remove the front grill and wipe the blade and inside the grill.  
Reassemble the fan by snapping the front grill into place.
- 4.3. Should the motor, speed control box or the power leads require service or maintenance contact your local service agent.
- 4.4. When not in use place the fan in its original box or cover the fan to protect from dust, and store in a safe, dry, childproof location.

fig 2

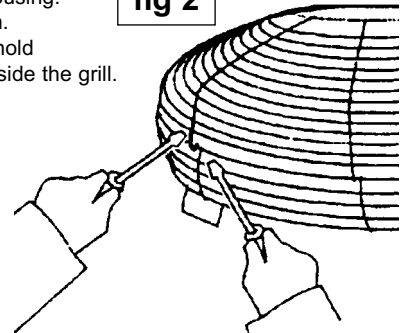

**Declaration of Conformity** We, the sole importer into the UK, declare that the products listed below are in conformity with the following EEC standards and directives

#### HIGH VELOCITY FAN Models HVF14 & HVF18

EN 60335-2-80  
89/336/EEC Electromagnetic Compatibility  
73/23/EEC Low Voltage Directive



The construction files for these products are held by the Manufacturer and may be inspected on request by contacting Jack Sealey Ltd

Signed by Mark Sweetman

16th February 2000

For Jack Sealey Ltd.  
Sole importer into the UK  
of Sealey Power Products

**NOTE:** It is our policy to continually improve products and as such we reserve the right to alter data, specifications and component parts without prior notice.

**IMPORTANT:** No liability is accepted for incorrect use of product. **WARRANTY:** Guarantee is 12 months from purchase date, proof of which will be required for any claim. **INFORMATION:** Call us for a copy of our latest catalogue on 01284 757525 and leave your full name and address including your postcode.



Sole UK Distributor  
Sealey Group.  
Bury St. Edmunds, Suffolk.



01284 757500



01284 703534

E-mail: sales@sealey.co.uk