

Thank you for purchasing a Sealey product. Manufactured to a high standard this product will, if used according to these instructions and properly maintained, give you years of trouble free performance.



IMPORTANT: PLEASE READ THESE INSTRUCTIONS CAREFULLY. NOTE THE SAFE OPERATIONAL REQUIREMENTS, WARNINGS AND CAUTIONS. USE THE PRODUCT CORRECTLY AND WITH CARE FOR THE PURPOSE FOR WHICH IT IS INTENDED. FAILURE TO DO SO MAY CAUSE DAMAGE AND/OR PERSONAL INJURY, AND WILL INVALIDATE THE WARRANTY. PLEASE KEEP INSTRUCTIONS SAFE FOR FUTURE USE.

1. SAFETY INSTRUCTIONS

1.1. ELECTRICAL SAFETY

WARNING! It is the responsibility of the owner and the operator to read, understand and comply with the following:
You must check all electrical products, before use, to ensure that they are safe. You must inspect power cables, plugs, sockets and any other connectors for wear or damage. You must ensure that the risk of electric shock is minimised by the installation of appropriate safety devices. A Residual Current Circuit Breaker (RCCB) should be incorporated in the main distribution board. We also recommend that a Residual Current Device (RCD) is used. It is particularly important to use an RCD with portable products that are plugged into a supply which is not protected by an RCCB. If in any doubt consult a qualified electrician. You may obtain a Residual Current Device by contacting your Sealey dealer.
You must also read and understand the following instructions concerning electrical safety.

1.1.1. The **Electricity at Work Act 1989** requires all portable electrical appliances, if used on business premises, to be tested by a qualified electrician, using a Portable Appliance Tester (PAT), at least once a year.

WARNING! The switch on this fan has components fitted to protect it against a possible voltage surge. When carrying out regular appliance checks, a voltage no higher than 250V should be applied for the purposes of insulation testing.

1.1.2. The **Health & Safety at Work Act 1974** makes owners of electrical appliances responsible for the safe condition of those appliances and the safety of the appliance operators. **If in any doubt about electrical safety, contact a qualified electrician.**

1.1.3. Ensure that the insulation on all cables and on the appliance is safe before connecting it to the power supply. See 1.1.1. and 1.1.2. and use a Portable Appliance Tester.

1.1.4. Ensure that cables are always protected against short circuit and overload.

1.1.5. Regularly inspect power supply cables and plugs for wear or damage and check all connections to ensure that none are loose.

1.1.6. **Important:** Ensure that the voltage marked on the appliance matches the power supply to be used and that the plug is fitted with the correct fuse - see fuse rating at right.

1.1.7. **DO NOT** pull or carry the appliance by the power cable.

1.1.8. **DO NOT** pull the plug from the socket by the cable.

1.1.9. **DO NOT** use worn or damaged cables, plugs or connectors. Immediately have any faulty item repaired or replaced by a qualified electrician. When an ASTA/BS approved UK 3 pin plug is damaged, cut the cable just above the plug and **dispose of the plug safely.** Fit a new plug according to the following instructions (UK only).

a) **Connect the GREEN/YELLOW earth wire to the earth terminal 'E'.**

b) **Connect the BROWN live wire to the live terminal 'L'.**

c) **Connect the BLUE neutral wire to the neutral terminal 'N'.**

d) **After wiring, check that there are no bare wires, that all wires have been correctly connected, that the cable outer insulation extends beyond the cable restraint and that the restraint is tight.**

Double insulated products, which are always marked with this symbol , are fitted with live (brown) and neutral (blue) wires only. To rewire, connect the wires as indicated above - **DO NOT** connect either wire to the earth terminal.

1.1.10. Products which require more than 13 amps are supplied without a plug. In this case you must contact a qualified electrician to ensure that a suitably rated supply is available. We recommend that you discuss the installation of an industrial round pin plug and socket with your electrician.

1.1.11. If an extension reel is used it should be fully unwound before connection. A reel with an RCD fitted is preferred since any appliance plugged into it will be protected. The cable core section is important and should be at least 1.5mm², but to be absolutely sure that the capacity of the reel is suitable for this product and for others which may be used in the other output sockets, we recommend the use of 2.5mm² section cable. If extension reel is to be used outdoors, ensure it is marked for outdoor use.

1.2. GENERAL SAFETY

WARNING! If a fan falls into water or other liquid, immediately switch off and disconnect from the mains power supply. Do not touch the fan until the mains power supply has been disconnected.

DO NOT stand the fan on its electrical power cable.

DO NOT insert any objects through the fan guard.

DO NOT cover the fan when in use.

DO NOT immerse the fan in water or any other liquid.

DO NOT allow children to operate the fan.

DO NOT stand the fan where it may be knocked over or off a surface, or where the lead may cause a person to trip.

DO NOT use the fan outdoors.

DO NOT use an extension cord unless it has been approved by an electrical authority.

DO NOT modify speed control or attempt to fit any additional external speed control device to the fan.

DO NOT operate the fan where there are harmful, explosive or flammable gases, fumes or hazardous substances.

When not in use place the fan in its original box or cover the fan to protect from dust, and store in a safe, dry, childproof location.

Use recommended parts only (non genuine parts may be dangerous, and will invalidate your warranty).

Always disconnect the fan from the power supply when moving it from one location to another and ensure the fan is stood on a level surface.

The fan air flow is powerful. Before using ensure there are no materials or items that may be erroneously moved by the stream of air.

Keep the fan clean and maintained in good condition. For electrical components or motor service contact an authorised service agent.

Disconnect the fan from the mains power when not in use, and before servicing or performing any maintenance.

Use the fan in dry areas only. Do not use in wet or areas with high condensation such as showers, pools etc.

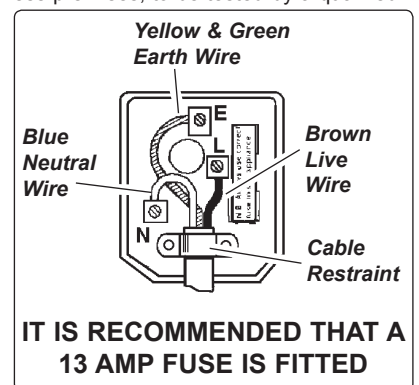

2. SPECIFICATION

DIAMETER:24"
 INPUT VOLTAGE: 230V
 MOTOR POWER:210 - 280W
 SPEED RANGE:900 - 1100rpm
 WEIGHT: 20kg

3. OPERATION

3.1. FAN OPERATION.

- WARNING! Ensure you read, understand and apply safety instructions before using the fan.**
- 3.1.1. The fan is easily transportable by means of the wheels provided. Lift by the handle on the main body of the fan on the side opposite the wheels and manoeuvre the fan into position. Ensure that there is nothing in front of the fan that may be disturbed when the fan is switched on.
- 3.1.2. Check that the speed control box situated in the recess in the rear grille of the fan is set to "OFF". Uncoil the power lead from its stowage position and plug into the mains power supply. Ensure that the power lead is not stretched or positioned in such a way as to cause a hazard. Switch the power on.
- 3.1.3. Turn the fan on by rotating the control knob from "OFF" to "1". If a greater air flow is required turn the knob to the "2 or 3" setting.
- 3.1.4. Adjust the direction of air flow by tilting the fan up or down within its frame or moving the whole unit from side to side.
- 3.1.5. When you have finished using the fan ensure you turn the speed control switch to "0" (off) and disconnect the fan from mains power.
- 3.1.6. Recoil the lead onto the stowage hooks situated within the recess in the rear grille.

4. MAINTENANCE

- WARNING! Ensure the fan is disconnected from the mains power supply before attempting any of the following:**
- 4.1. Use a soft, damp cloth to clean the body of the fan.
DO NOT splash water onto the fan and never allow water to drip onto the motor housing.
DO NOT use solvents, petroleum, paint thinner or other chemicals to clean the fan.
- 4.2. If it becomes necessary to clean the fan blades or inside the fan body, remove the front grille by undoing the 6 screws. Wipe with a damp cloth only. Replace the grille and refix using the screws and rectangular washers.
- 4.3. Should the motor, speed control box or the power lead require service or maintenance, contact your local service agent.
- 4.4. When not in use, place the fan in its original box, or cover the fan to protect from dust, and store in a safe, dry, childproof location.

5. SPARE PARTS

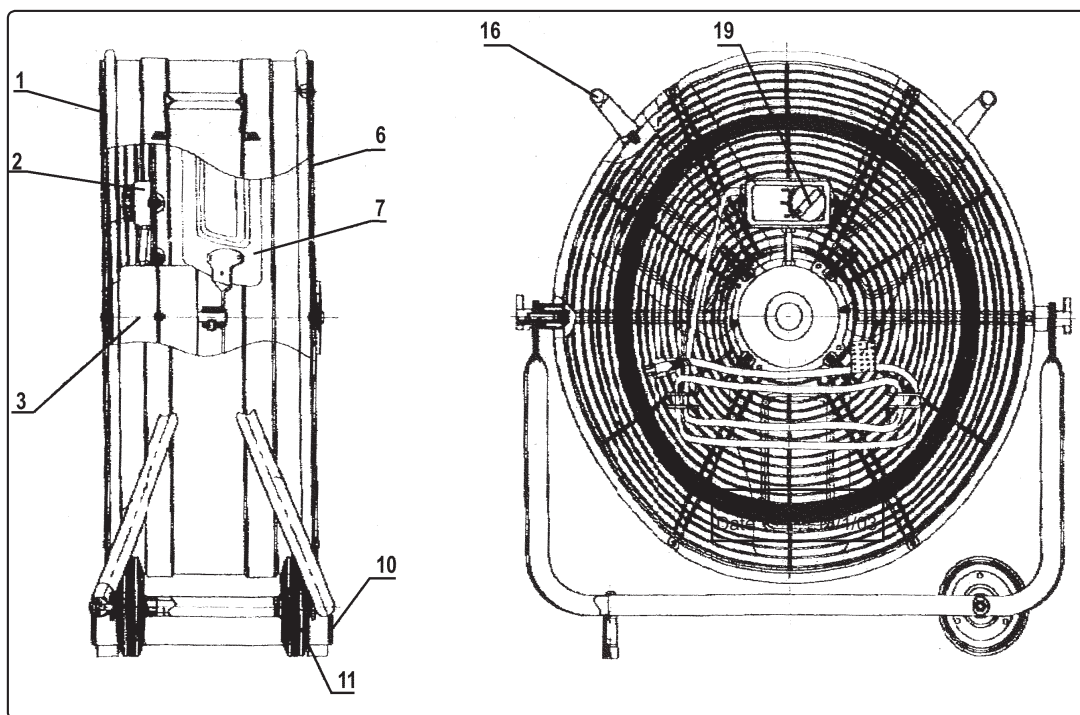

ITEM	PART NO.	DESCRIPTION	ITEM	PART NO.	DESCRIPTION
1	HVD24.01	REAR GRILLE	10	HVD24.10	PLASTIC PLUG
2	HVD24.02	SWITCH	11	HVD24.11	WHEEL
3	HVD24.03	MOTOR	16	HVD24.16	HANDLE
6	HVD24.06	FRONT GRILLE	19	HVD24.19	SWITCH KNOB
7	HVD24.07	BLADE			

NOTE: It is our policy to continually improve products and as such we reserve the right to alter data, specifications and component parts without prior notice.

IMPORTANT: No liability is accepted for incorrect use of this product.

WARRANTY: Guarantee is 12 months from purchase date, proof of which will be required for any claim.

INFORMATION: For a copy of our latest catalogue and promotions call us on 01284 757525 and leave your full name and address, including postcode.



Sole UK Distributor, Sealey Group,
 Kempson Way, Suffolk Business Park,
 Bury St. Edmunds, Suffolk,
 IP32 7AR

01284 757500

www.sealey.co.uk

01284 703534

sales@sealey.co.uk