



HEAD TORCH 1.8W SMD LED INTRINSICALLY SAFE ATEX/IECEX APPROVED

MODEL NO: **HT452IS.V2**

Thank you for purchasing a Sealey product. Manufactured to a high standard, this product will, if used according to these instructions, and properly maintained, give you years of trouble free performance.

IMPORTANT: PLEASE READ THESE INSTRUCTIONS CAREFULLY. NOTE THE SAFE OPERATIONAL REQUIREMENTS, WARNINGS & CAUTIONS. USE THE PRODUCT CORRECTLY AND WITH CARE FOR THE PURPOSE FOR WHICH IT IS INTENDED. FAILURE TO DO SO MAY CAUSE DAMAGE AND/OR PERSONAL INJURY AND WILL INVALIDATE THE WARRANTY. KEEP THESE INSTRUCTIONS SAFE FOR FUTURE USE.



Refer to instructions

1. SAFETY

- WARNING! DO NOT** change batteries in hazardous locations.
- WARNING!** To reduce the risk of explosion **DO NOT** mix new batteries with used batteries, or mix batteries from different manufacturers or from different types.
- WARNING!** Remove the batteries when unused for a period of time to prevent battery leakage in the device.
- The screw shall be secured tightly after opening and closing of the enclosure.
- Substitution of components may impair the head torches intrinsic safety.
- Clean the head torch only with damp cloth to avoid static electricity.
- DO NOT** flash the light beam directly to humans eyes.
- Always use the device following the regulations of each country.

2. INTRODUCTION

Single high power 1.8W SMD LED produces extremely bright, white light with an output of 216/100 lumens (high/low) and a working range up to 100m. Three mode push-button for high, low and off settings. Operating time 5/12 hours. Intrinsically safe for use in hazardous locations. Lightweight, tough and durable casing which will sustain high impacts and drops. Adjustable headband attaches to hard hat or head. Light angle adjustable by up to 90° to suit every situation. Built-in gas release vent. Battery compartment secured with screws to prevent inadvertent opening in hazardous area.

3. SPECIFICATION

Model No:	HT452IS
Battery:	3 x AAA (not included)
LED Type:	1.8W SMD
Lumen Output:	High/Low; 216/100lm

4. OPERATION

- 4.1. Adjust head strap to fit the circumference of your head.
- 4.2. Push the top button to operate. The sequence is high and then low mode, fig.1.

5. MAINTENANCE

- 5.1. **BATTERY REPLACEMENT (FIG.2):**
 - 5.1.1. Remove the screws to gain access to the battery case.
 - 5.1.2. Use only AAA batteries (not included).
 - 5.1.3. Clean the head torch only with damp cloth to avoid static electricity
 - 5.1.4. Store lamp in a dry, childproof area.



fig.1

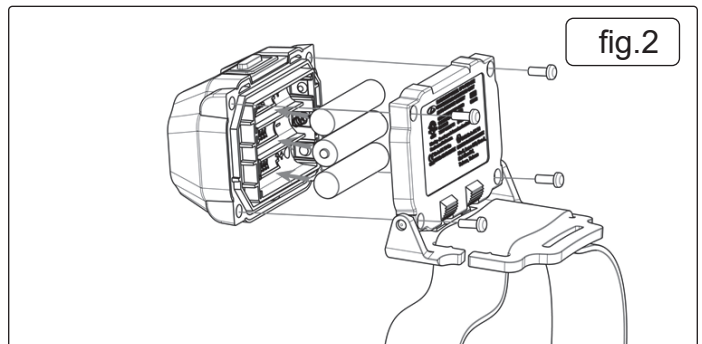

fig.2



ENVIRONMENT PROTECTION

Recycle unwanted materials instead of disposing of them as waste. All tools, accessories and packaging should be sorted, taken to a recycling centre and disposed of in a manner which is compatible with the environment. When the product becomes completely unserviceable and requires disposal, drain any fluids (if applicable) into approved containers and dispose of the product and fluids according to local regulations.



WEEE REGULATIONS

Dispose of this product at the end of its working life in compliance with the EU Directive on Waste Electrical and Electronic Equipment (WEEE). When the product is no longer required, it must be disposed of in an environmentally protective way. Contact your local solid waste authority for recycling information.



BATTERY REMOVAL SEE SECTION 5

Under the Waste Batteries and Accumulators Regulations 2009, Jack Sealey Ltd are required to inform potential purchasers of products containing batteries (as defined within these regulations), that they are registered with Valpak's registered compliance scheme. Jack Sealey Ltd Batteries Producer Registration Number (BPRN) is BPRN00705.

Note: It is our policy to continually improve products and as such we reserve the right to alter data, specifications and component parts without prior notice.

Important: No Liability is accepted for incorrect use of this product.

Warranty: Guarantee is 12 months from purchase date, proof of which is required for any claim.

Sealey Group, Kempson Way, Suffolk Business Park, Bury St Edmunds, Suffolk. IP32 7AR



01284 757500



sales@sealey.co.uk



www.sealey.co.uk