

Thank you for purchasing a Sealey Product. Manufactured to a high standard this product will, if used according to these instructions and properly maintained, give you years of trouble free performance.



IMPORTANT

PLEASE READ THESE INSTRUCTIONS CAREFULLY. NOTE THE SAFE OPERATIONAL REQUIREMENTS, WARNINGS AND CAUTIONS. USE THIS PRODUCT CORRECTLY AND WITH CARE FOR THE PURPOSE FOR WHICH IT IS INTENDED. FAILURE TO DO SO MAY CAUSE DAMAGE AND/OR PERSONAL INJURY AND WILL INVALIDATE THE WARRANTY. PLEASE KEEP INSTRUCTIONS SAFE FOR FUTURE USE.



GENERAL RULES

Read instruction manual carefully before using the headlamp beam setter (HBS).

TO AVOID DAMAGE ENSURE THE FOLLOWING ARE STRICTLY APPLIED.

- DO NOT allow unqualified persons to operate the HBS.
- DO NOT use the HBS in direct sunlight.
- DO NOT splash the HBS with water or any other liquid.
- DO ensure the work area is well ventilated.

- DO ensure that there is good lighting.
- DO apply handbrake on vehicle.
- DO avoid sudden changes in temperature.
- DO avoid sudden vibration.

1. DESCRIPTION

The SEALEY HEADLAMP BEAM SETTER, HBS971 series, is supplied with a rotating column, mirror and visor. The HBS97 series has the addition of a rail set. Either HEADLAMP BEAM SETTER may be used for checking headlights on cars, heavy goods vehicles and motorcycles.

SPECIFICATION:	Height1750mm	Maximum height of beam measurement1410mm
	Width650/670mm	Minimum height of beam measurement240mm
	Length690mm	Focal length500mm

2. ASSEMBLY

A	BASE	D	MIRROR-VISOR
B	COLUMN	E	OPTICAL SYSTEM
C	VERTICAL SLIDING SYSTEM	F	BRAKE

- 2.1. Insert the pivot pin end of column B into the bearings in base A.
- 2.2. Retain column by screwing special washer onto end of pivot pin.
- 2.3. Lock column using brake pedal F. If necessary, realign pedal on shaft by loosening the two clamp screws, rotating pedal to a suitable position and retightening the screws.
- 2.4. Attach mirror-visor D to mounting plate at the top of column B with the two screws provided (in end of visor).
- 2.5. Fit the optical system E to the vertical sliding system C using the two screws and washers provided (fit larger washer over slotted hole).

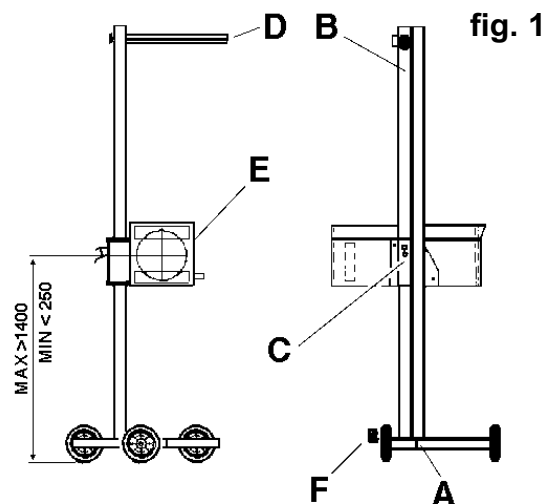

3. WORKING SURFACE

- 3.1. Position the vehicle on the designated headlamp aim standing area.
- 3.2. When positioning the HBS ensure the floor is perfectly even and level.
- 3.3. If this is not possible the vehicle and HBS must be on the same slope, which must not exceed 0.5°.
- 3.4. Headlights must not be checked where surface angle exceeds 0.5° (see fig. 2).

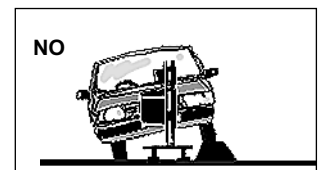
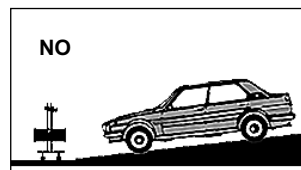
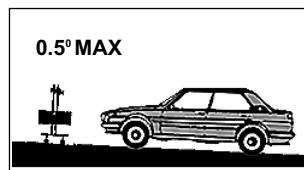
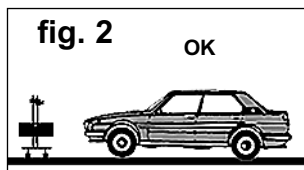

4. VEHICLE PREPARATION

4. 1. Straighten vehicle wheels.
4. 2. Check the tyre pressures.
4. 3. Ensure the headlights are clean and dry.
4. 4. If the vehicle is fitted with manual or electric headlamp levelling device, ensure this is set for vehicle with normal load.
4. 5. Remove anything which could alter the attitude of the vehicle, i.e. load, snow, ice, mud, etc.

5. OPTICAL POSITIONING

5.1. Positioning

Locate the HBS approximately 200 to 500mm from the vehicle headlamp.

- 5.1.1. Standing behind the HBS, use the visor to align with a horizontal, or two symmetrical points on the vehicle i.e. the bonnet lip or the bottom of the windscreen.
- 5.1.2. Ensure the visor line is parallel with the horizontal, or symmetrical selection, by rotating the column, to ensure that the HBS is square with the front of the vehicle.
- 5.1.3. Measure the height of the centre of the headlamp from the floor - say 650mm as an example.
- 5.1.4. Squeeze the locking lever (fig. 3. C) on the vertical sliding system and move the system up or down the column until the top edge of the slider (fig. 3.D) aligns with 65cm (650mm) on the column scale. Release locking lever. Centre of lens will now be at the same height (650mm) as the centre of the headlamp.
- 5.1.5. Use the sighting line on the top of the optical system housing to horizontally align the HBS with the centre of the headlamp.

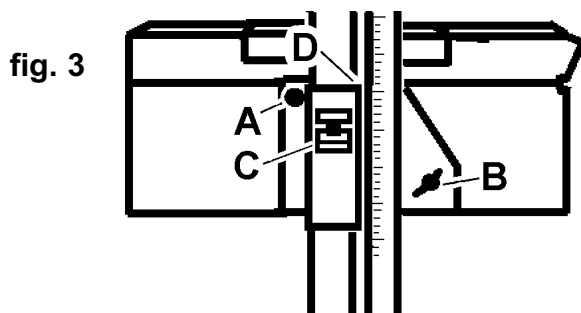

fig. 3

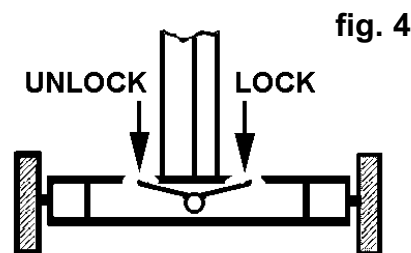

fig. 4

5.2. HBS Column Brake

The HBS is fitted with a rotating column, which aids correct alignment. To release or apply the column brake put pressure on foot pedal (fig. 4).

6. METHOD OF INSPECTION

- 6.1. Start engine, so that battery is not drained.
- 6.2. Align the HBS with the centre of the headlamp to be tested, as in Section 5.
- 6.3. With an assistant sitting in the driving seat, switch on the headlamp to the beam, dip or main, which is to be checked.
Note: When checking headlamp aim on vehicles with hydropneumatic suspension systems, it is necessary to have the engine idling.
- 6.4. Determine the appropriate dip beam image and the aim (see figs. 6 & 7). Headlamps of older vehicles (approx. pre 1950) may have beam images which do not conform. In such cases check:
 - a) **DIP BEAM** headlamps are aimed so they do not dazzle, ie the brightest part of the beam image is aimed at least 0.5% below the horizontal, or, for headlamps which cannot be checked on dip beam, check:
 - b) **MAIN BEAM** headlamps are aimed so that the beam image centre is on or slightly below the horizontal (fig. 8).

6.5. Graduated Screen

IMPORTANT

The HBS system uses a fixed graduated screen in accordance with the requirements of the MOT regulations.

CORRECT LIGHT PROJECTION ON THE LINE 0.5% (BEAM LIGHT)

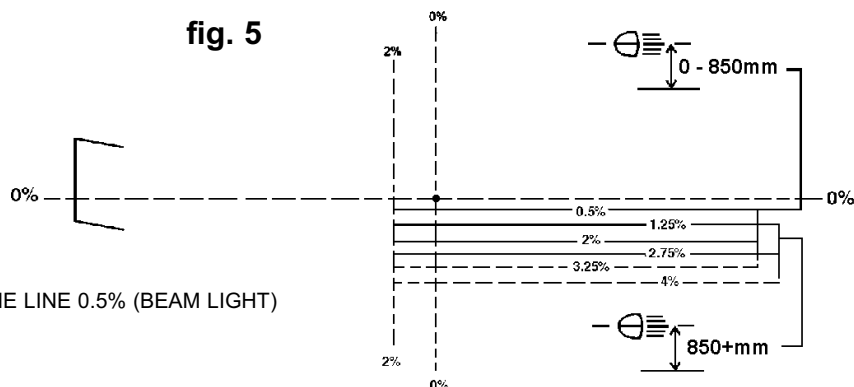
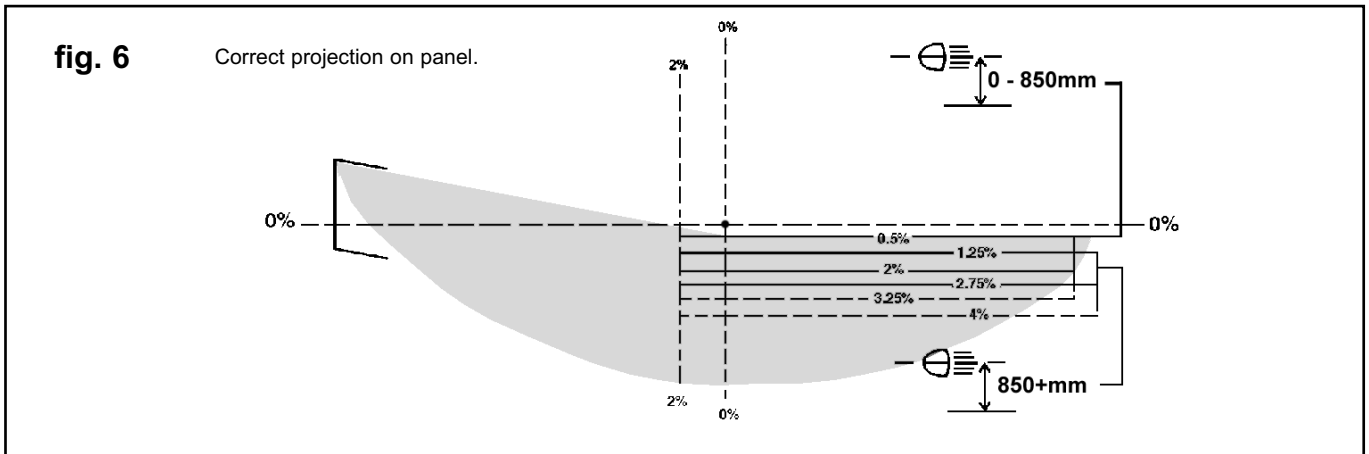

fig. 5

6.6. Dipped Beam

- 6.6.1. Prepare the HBS and the car as previously instructed, then turn on the dipped beam.
- 6.6.2. Check that the headlamp beam tolerances are in accordance with the MOT inspection manual and are within the operating tolerances specified by the manufacturer.
- 6.6.3. Adjust the headlight(s) until you obtain the required result.
- 6.6.4. When testing the more commonly used asymmetrical headlight (see fig. 6), remember that the projection will light up a section on the **LEFT** hand side of the plate at an angle of about 15° above the horizontal plane. Just under the centre, on the left, a small zone will appear brighter than the rest of the projection.

ASYMMETRICAL DIPPED BEAM



SYMMETRICAL DIPPED BEAM

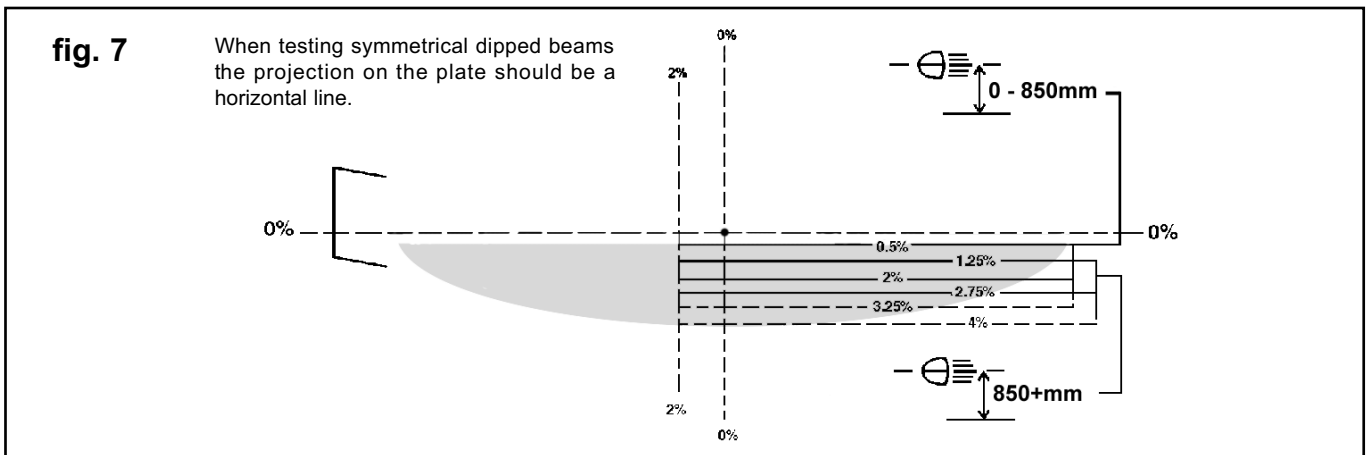

MAIN BEAM

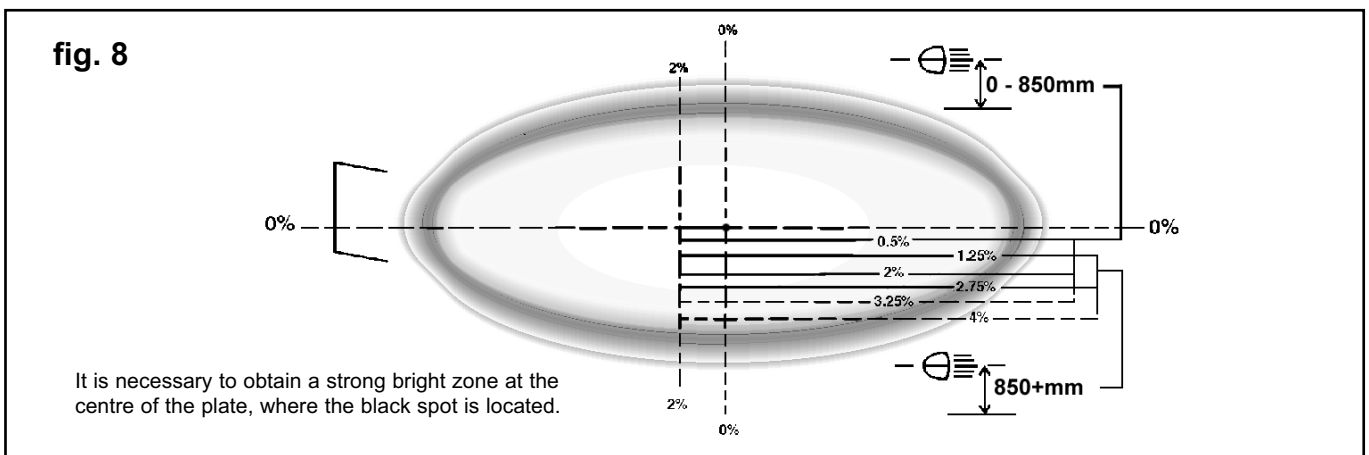

7. THE LUXMETER

In addition to the numerically calibrated scales the luxmeter has a colour coded scale for main beam intensity which should be read as follows:

Main Beam

1. Indicator at RED/GREEN (BAD/GOOD) limit: Acceptable for vehicles travelling under 30mph (48km/h) and motorcycles.
2. Indicator at the centre of GREEN (GOOD): Acceptable for vehicles travelling over 30mph (48km/h).
3. Indicator on BLUE (HALOGEN): Acceptable for vehicles with halogen headlights.

8. CALIBRATION

We suggest that the unit has periodic calibration checks in situ. If the unit is covered by a service agreement with the MOT package installer, they will carry this out on your behalf. You may however, wish to calibrate the unit yourself.

The headlamp beam setter can be recalibrated using a laser alignment calibration unit. We recommend the Sealey AK9999 (available from your authorised Sealey dealer).

We recommend that the laser calibration device be set up and levelled first of all, the beam setter can then be manoeuvred easily on its stand with reference to the position of the laser. The laser can be placed on any surface such as a car bonnet, box, table etc of suitable height.

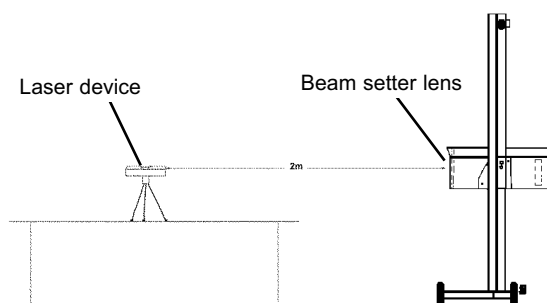

- 8.1 Using the calibrated spirit level within the laser alignment calibration device, ensure that the unit is flat and level.
- 8.2 Switch the laser on. Manoeuvre the beam setter in order to centre the laser beam in the beam setter lens. This must be done "by eye". There is a $\pm 20\text{mm}$ tolerance on centralisation of the beam through the lens. The beam setter should be approximately 2m from the laser.
- 8.3 The dot projected onto the aiming screen should bisect the 0° line, at the far left, centre and far right of the screen. It is necessary at this point to rotate the column through the vertical axis, to track the beam from one side of the aiming screen to the other. Take care to ensure that the laser remains level throughout.

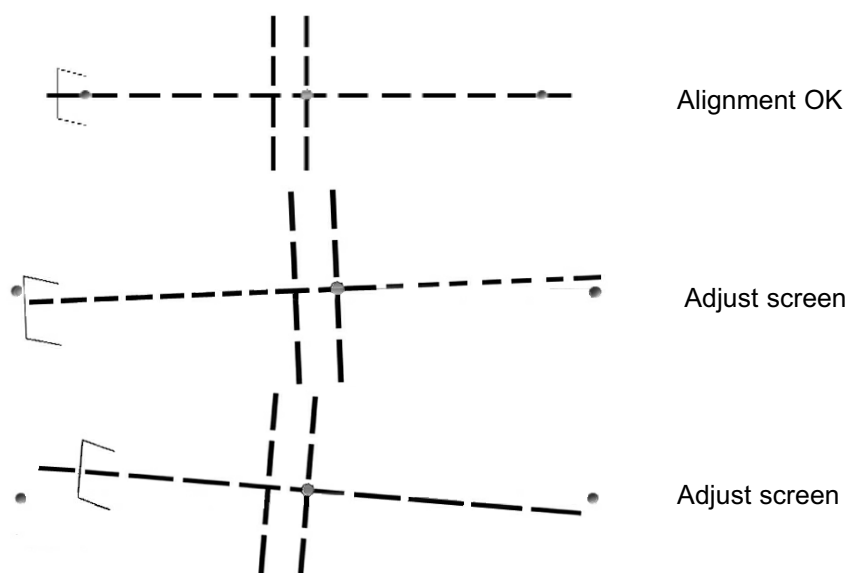

- 8.4 To adjust the aiming screen, use the two holding screws.
 - 8.4.1 Loosen the screws and reposition the screen, so that the projected laser dot correctly bisects the 0° line.
 - 8.4.2 Retighten the screws, taking care not to move the screen back out of position.

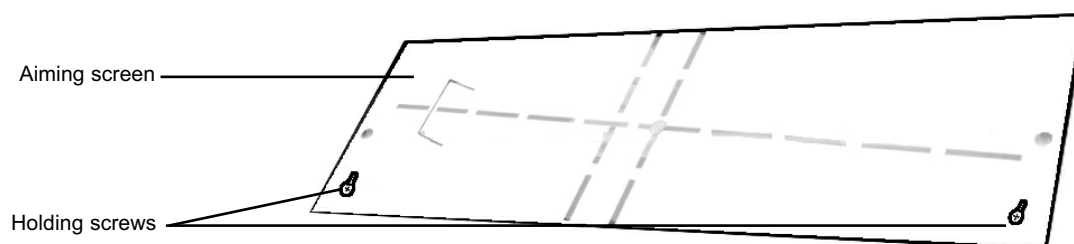

9. OTHER INFORMATION

The Headlamp Beam Setter is equipped with a spirit level located on the base of the optical box, which is visible through the transparent panel. To level the box, loosen screws (fig.3.A & B) located on the side of the box and adjust the box until the spirit level registers horizontal. Re-tighten the screws. The box level must be checked every time it is used on a different working surface.

10. CARE OF THE BEAM SETTER

- 10.1. The paint work is detergent resistant. Clean with a damp cloth, removing any stains. A small amount of alcohol may be applied to stubborn areas of grime.
- 10.2. DO NOT leave the machine in areas where corrosive vapour is present, i.e. from battery charging or paint spraying etc.
- 10.3. DO NOT oil the column.
- 10.4. An optical box dust cover is available upon request.

NOTE: It is our policy to continually improve products and as such we reserve the right to alter data, specifications and component parts without prior notice.

IMPORTANT: No liability is accepted for incorrect use of the product.

WARRANTY: Guarantee is 12 months from purchase date, proof of which will be required for any claim.

INFORMATION: For a copy of our latest catalogue and promotions call us on 01284 757525 and leave your full name and address, including postcode.



**Sole UK Distributor,
Sealey Group,
Bury St. Edmunds, Suffolk.**

 01284 757500

 01284 703534

 sales@sealey.co.uk

 www.sealey.co.uk