



# INSTRUCTIONS FOR: GALVANIZED STEEL SHED 1.5 x 0.8 x 1.9m WITH SIDE DOOR.

MODEL NO: **GSS150819SDG**

Thank you for purchasing a Sealey product. Manufactured to a high standard, this product will, if used according to these instructions, and properly maintained, give you years of trouble free performance.



**IMPORTANT:** PLEASE READ THESE INSTRUCTIONS CAREFULLY. NOTE THE SAFE OPERATIONAL REQUIREMENTS, WARNINGS & CAUTIONS. USE THE PRODUCT CORRECTLY AND WITH CARE FOR THE PURPOSE FOR WHICH IT IS INTENDED. FAILURE TO DO SO MAY CAUSE DAMAGE AND/OR PERSONAL INJURY AND WILL INVALIDATE THE WARRANTY. KEEP THESE INSTRUCTIONS SAFE FOR FUTURE USE.

## 1. SAFETY

- WARNING!** Ensure Health & Safety, local authority, and general workshop practice regulations are adhered to when building this shed.
- Keep the work area clean, uncluttered and ensure there is adequate lighting.
- Keep children and unauthorised persons away from the working area.
- DO NOT** use the shed for any purpose other than that for which it is designed.
- Use appropriate safety clothing including eye protection.
- Note:** The assembly of this product will require assistance.
- DO NOT** attempt to assemble in windy weather.

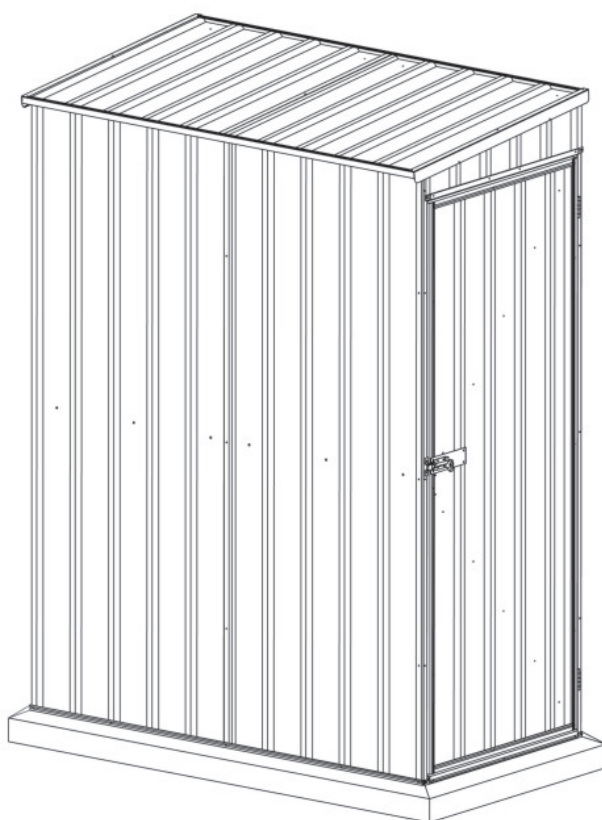

## 2. INTRODUCTION

Galvanized, steel panels easily assembled to form a rigid and secure shed. Has skillion (sloping) roof and single door. Door are secured by cross bolt and eyelet which will accept a padlock (not included) for additional security. Supplied with bolt-down fixing kit.

## 3. SPECIFICATION

Model No: ..... **GSS150819SDG**  
 Overall Size (W x D x H\*): ..... 1500 x 800 x 1900mm  
 Roof Type: ..... Skillion  
 \* Minimum wall height

## 4. CONCRETE PLINTH SLAB

**Concrete Slab:** It is recommended that your new shed is secured to a concrete slab as shown below.

Please ensure that your site is level. It is recommended that your slab is 100mm thick, you use a plastic membrane and a suitable reinforcing mesh. We recommend that you make your slab 100mm bigger than the base dimensions of your shed. This will allow for a 50mm edge around your shed. We recommend that you slope the 50mm edges downward by 10mm so that rain water will drain away from your shed.

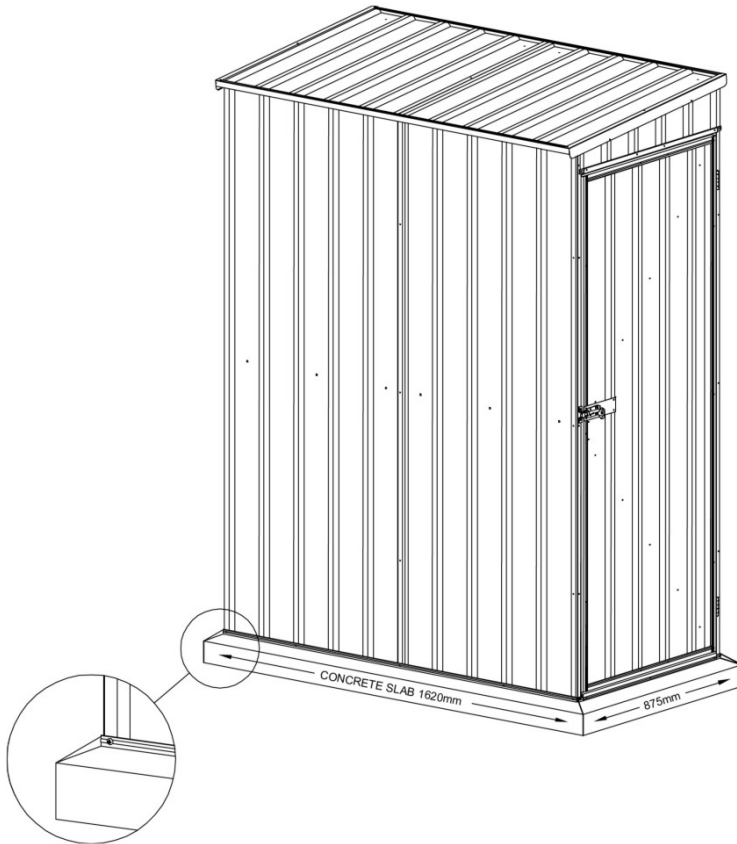

## 5. TOOLS REQUIRED

Electric Drill



Cordless Drill



Tape Measure



Phillips Screw Driver



8mm Masonary Bit



Pop Rivet Gun



Rubber Mallet



Step Ladder (2)



Adjustable spanner



3mm Masonary bit



Saw Horse/Trestle



Pencil



Gloves













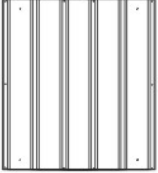

Protective Eyewear

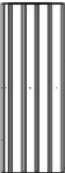









## 6. CONTENTS

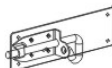

**Check contents:** Lay out all components with the part numbers facing upwards and check off against the parts lists on the next four pages. In the unlikely event of a missing component please contact your local Sealey dealer.

Picture	Description	Component	Location	Part No.	QTY	Check
	Sheet	sheet 1980 x 770	rear wall	1L	1	
	Sheet	sheet 1980 x 770	rear wall	1A	1	
	Sheet	sheet 1900-1980 x 770	side wall	2E	1	
	Sheet	sheet 80-160 x 770	side wall	2F	1	
	Sheet	sheet 855 x 770	roof	3	2	
	Sheet	sheet 1900 x 770	front	9S	1	
	Sheet	sheet 1900 x 770	front	9A	1	
	Door	sheet 1780 x 720	door	5C	1	
	Channel	channel 1508	roof	20A	2	

	Jamb	Jamb 1898	side wall	41F	1	
	Jamb	Jamb 1898	side wall	41G	1	
	Jamb	Jamb 723	side wall	D2	1	
	Lip	lip 856	roof	50	2	

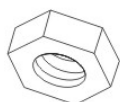
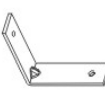
#### FITTINGS PACK

Picture	Component	QTY	Picture	Component	QTY
	Self tapping screws(10mm)	120		Self tapping screws(16mm)	12
	Ø4 x 10mm Rivet	6		Ø3 x 10mm Rivet	6
	Pad shoot bolt Part No 70	1		Keeper Part No 71	1
	Bracket	6		5/16*19mm Hexagonal bolt	6
	5/16 Hexagonal Nut	6		Mid height wall bracket Part No 72	2

	Self tapper safety cover	25		Channel safety cover (L type)	1
	Channel safety cover (R type)	1		Sleeve anchor bolt	6

6.1. Please note some component descriptions may differ in manual text to listings, always use pictures from listings to double check component identity. ie M8 fixings may be supplied in lieu of 5/16”.

# 7. PARTS DIAGRAM

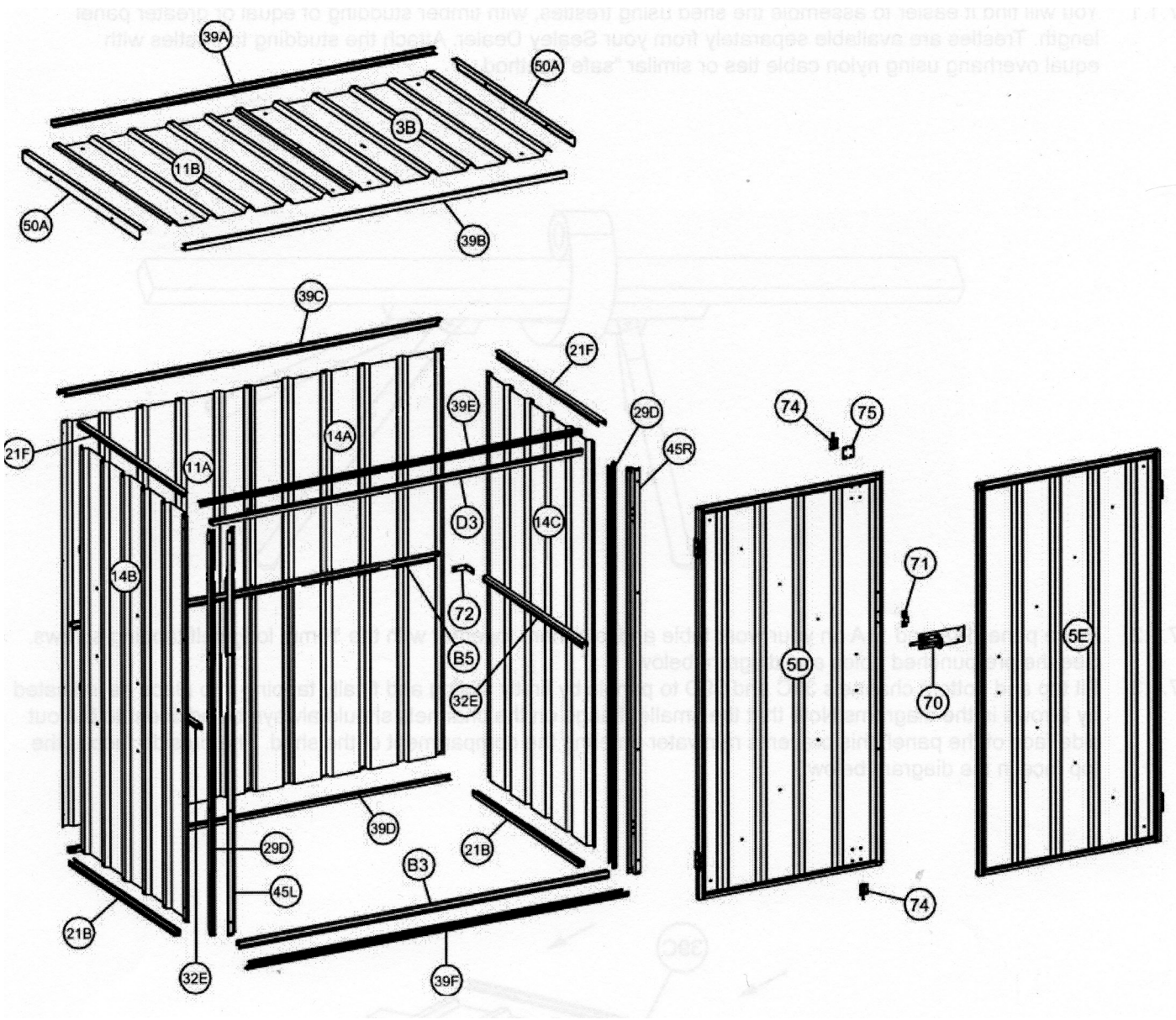

## 8. ASSEMBLY

### 8.1. ASSEMBLE THE REAR WALL PANELS

- 8.1.1. You will find it easier to assemble the shed using trestles with timber studding of equal or greater panel length. Trestles can be supplied separately by your Jack Sealey dealership. Attach the studding to trestles with equal overhang using nylon cable ties or similar "safe" method.

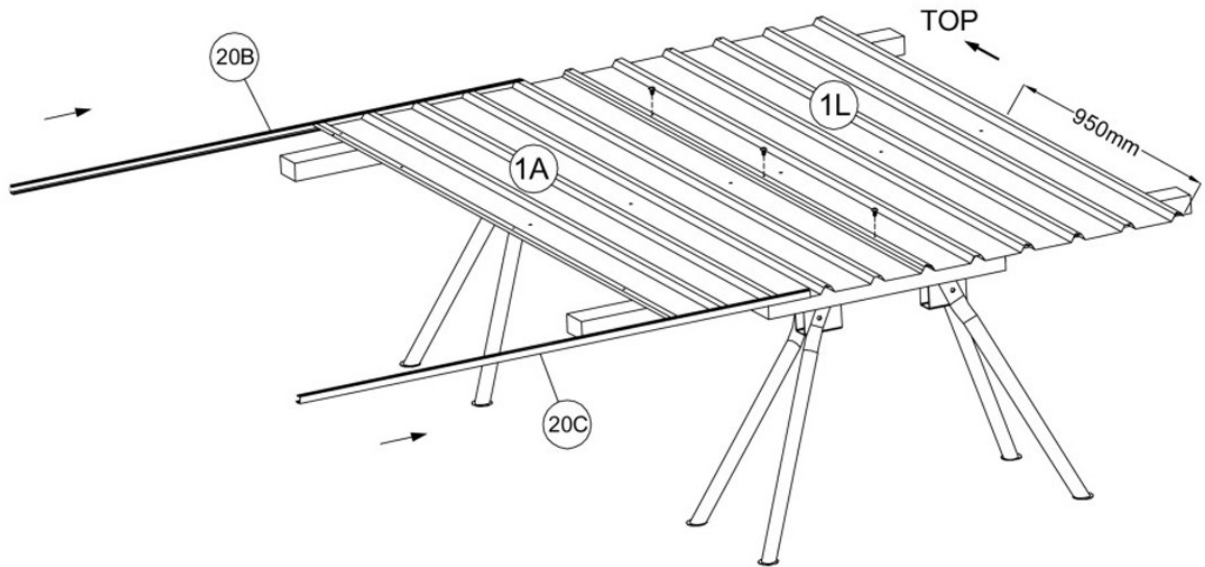

- 8.1.2. Place panel 1A and 1L on your work table and join them together with the 10mm long self tapping screws. See the pre-punched holes and both diagrams.
- 8.1.3. Fit top and bottom channels 20B and 20C to panels by firstly sliding and finally tapping into place as indicated by arrows in the diagrams. Note that the smaller flange on the channels should always be adjacent to the out side face of the panel; this prevents rainwater entering the compartment of the shed. The outside face is the top face in both diagrams.

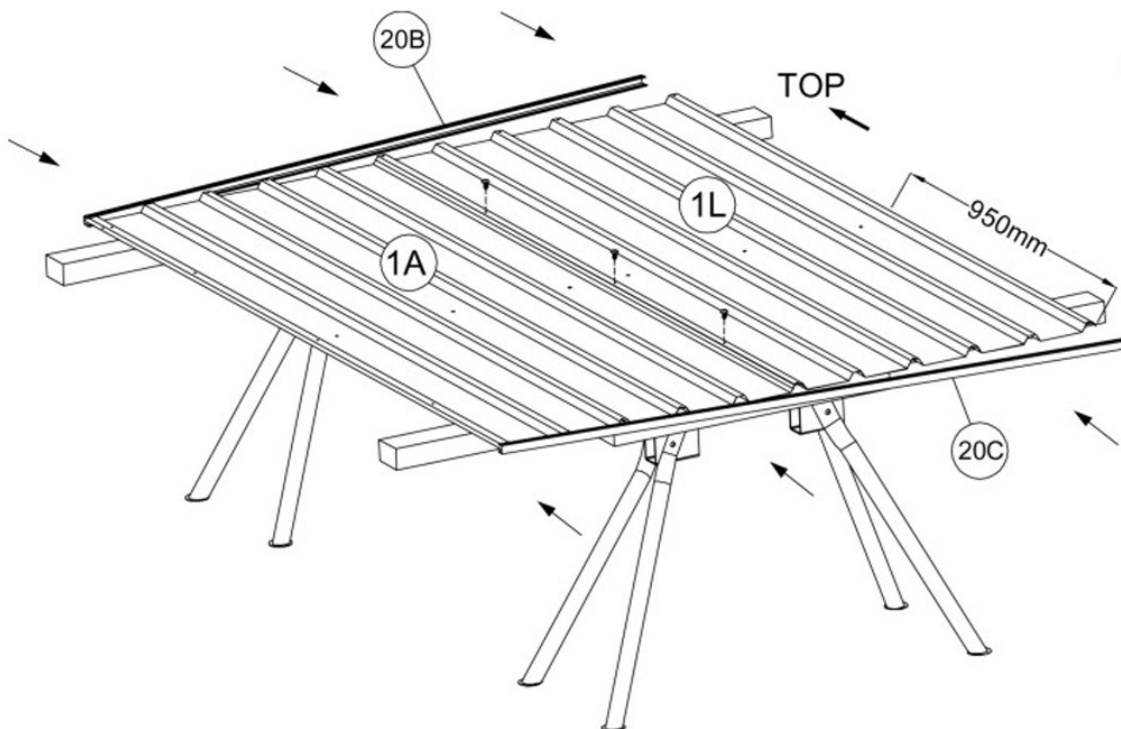

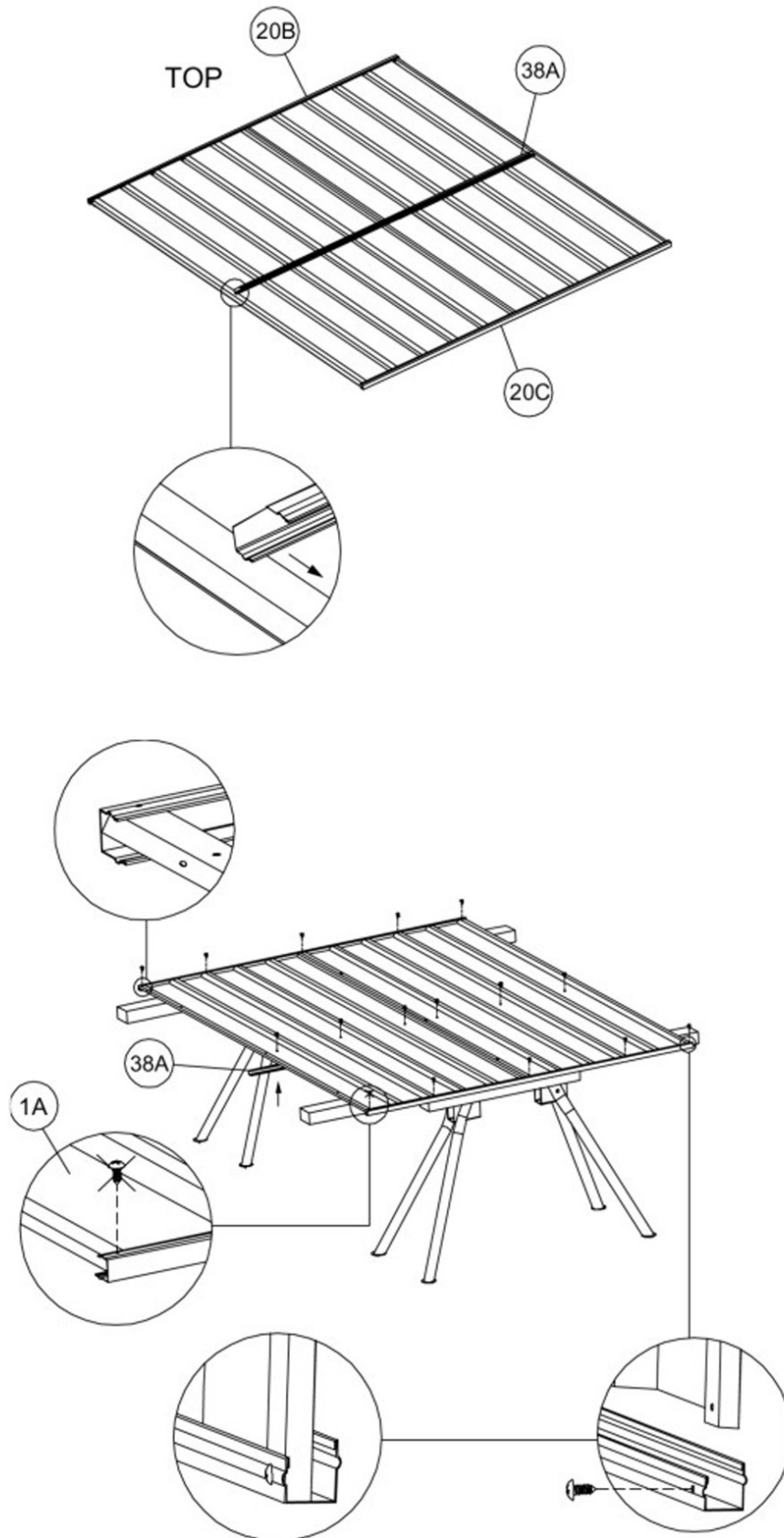

- 8.1.4. Fit item 38A the mid height wall channel to the panel and position it by the pre-punched holes and 10mm long self tapping screws. Note this channel is fitted with the flat face uppermost.
- 8.1.5. With self tapping screws fix items 20B and 20C to top and bottom edges.

8.2. ASSEMBLE THE END WALL PANEL (opposite door).

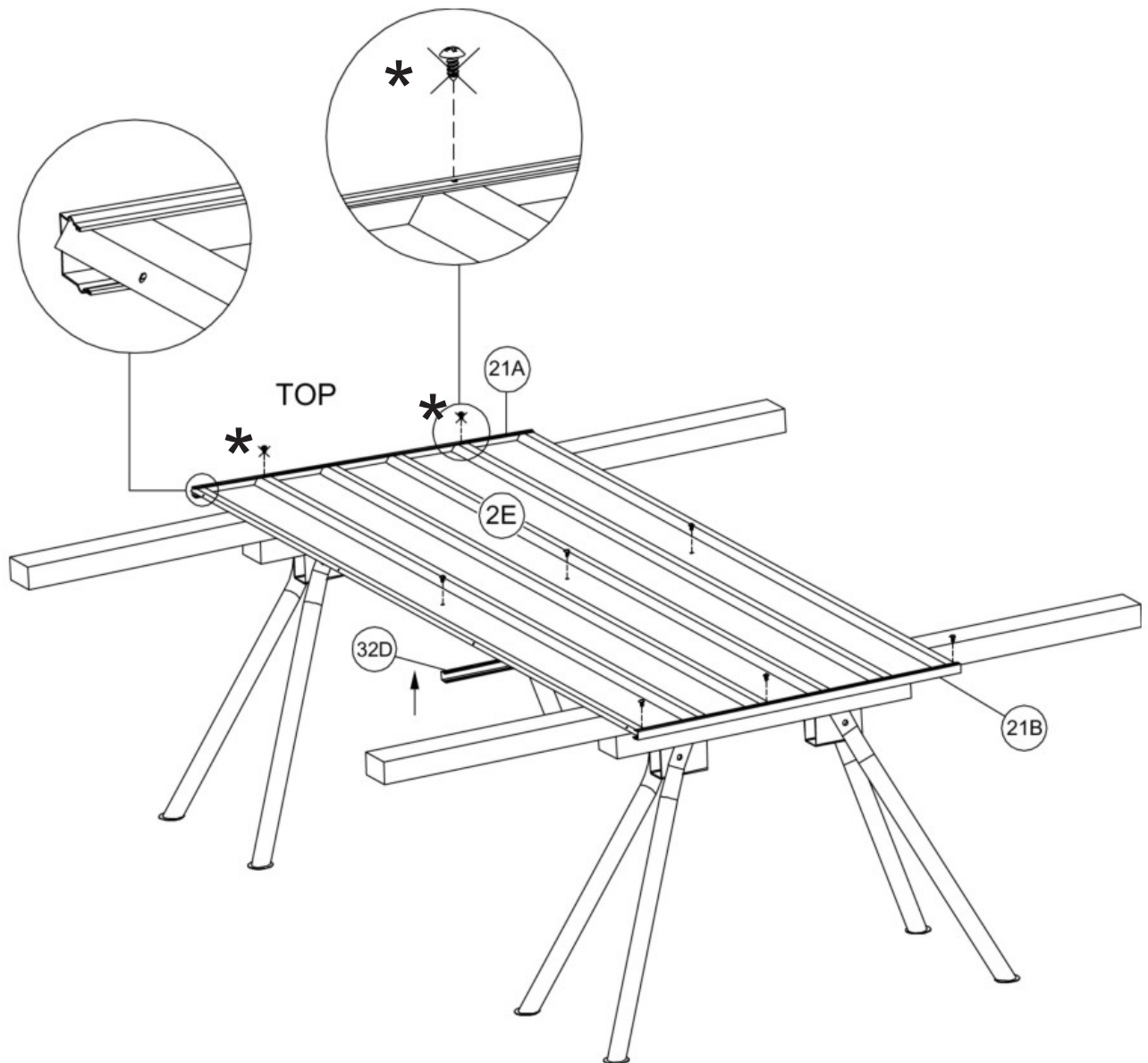

- 8.2.1. Place panel 2E on your work table.
- 8.2.2. Fit top and bottom channels 21A and 21B to panel by firstly sliding and finally tapping into place as indicated by arrows in the diagrams. Note that the smaller flange on the channels should always be adjacent to the out side face of the panel. The outside face is the top face in both diagrams.
- 8.2.3. Fit item 32D the mid height wall channel to the panel and position it by the pre-punched holes and 10mm long self tapping screws. Note this channel is fitted with the flat face uppermost, ie. nearest the "top".
- 8.2.4. With self tapping screws fix item 21B to bottom edge, but do not screw fix item 21A to top edge at this stage, see places marked with asterisk \*.



8.3. ASSEMBLE THE FRONT WALL PANELS

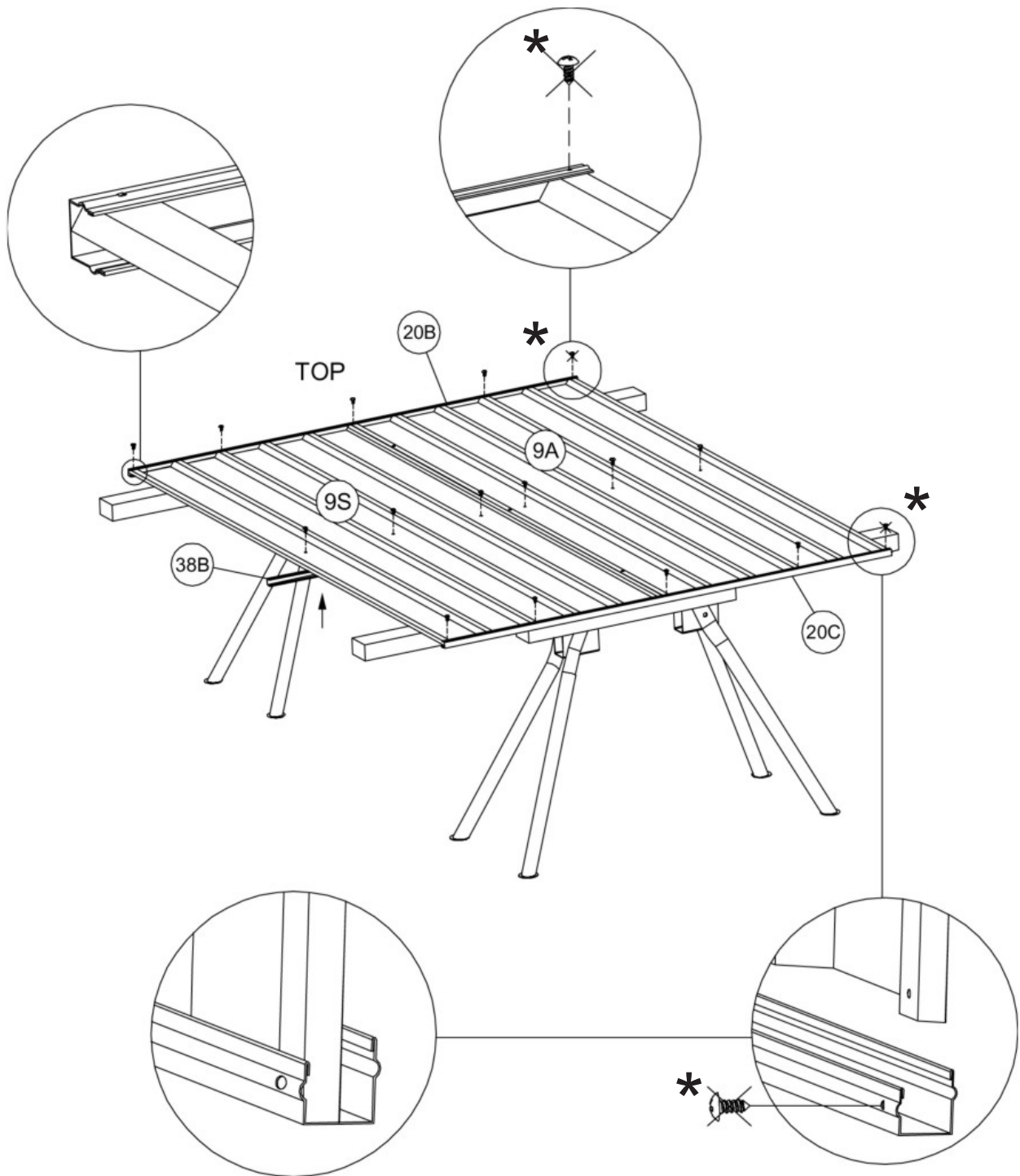

- 8.3.1. Place panel 9A and 9S on your work table and join them together with the 10mm long self tapping screws. See the pre-punched holes and both diagrams.
- 8.3.2. Fit top and bottom channels 20B and 20C to panels by firstly sliding and finally tapping into place. Note that the smaller flange on the channels should always be adjacent to the outside face of the panel. The outside face is the diagram. Fix both with 10mm long self tapping screws except for positions marked with asterisk \*, which are not fixed at this stage.

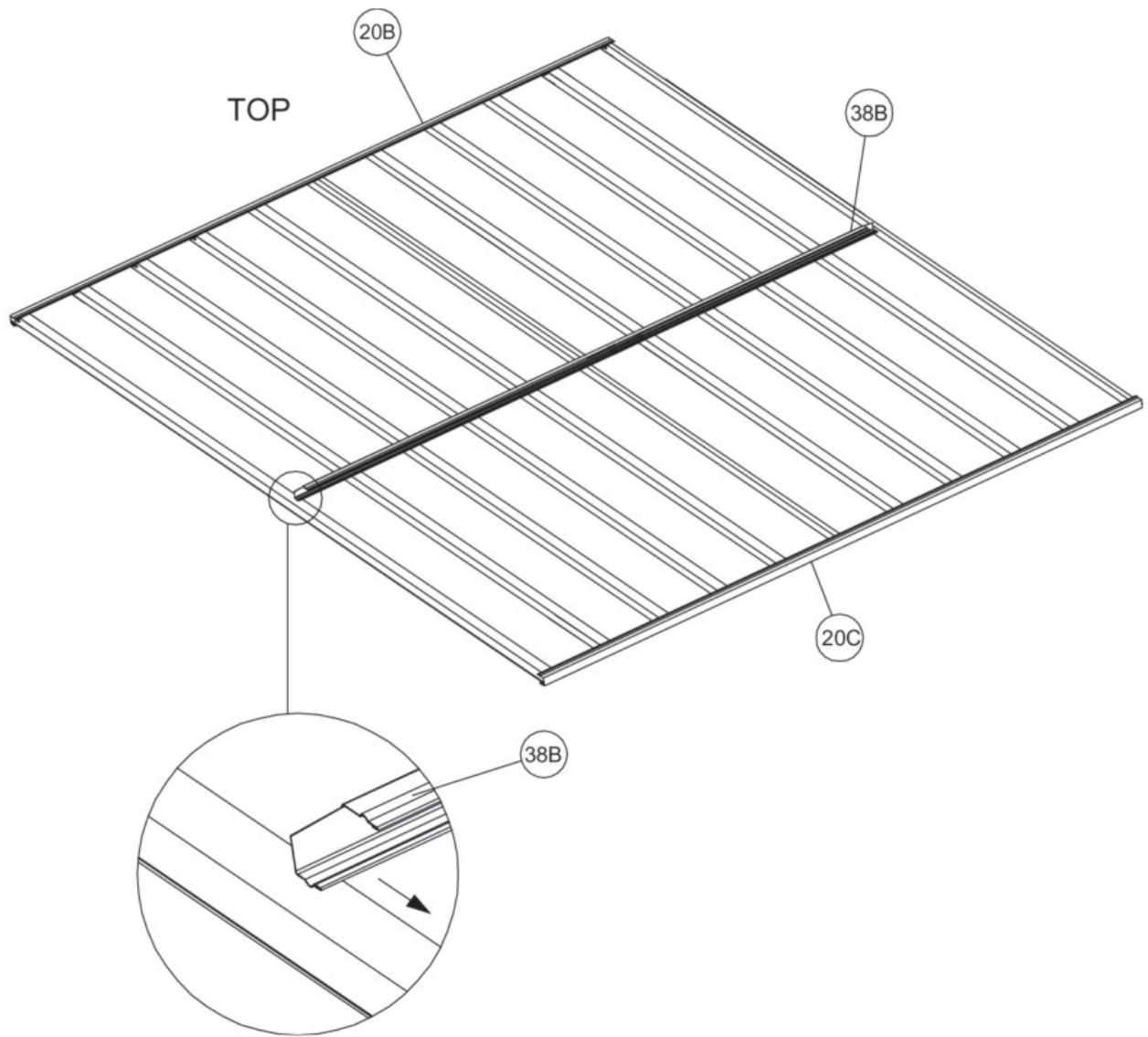

- 8.3.3. Fit item 38B the mid height wall channel to the panel and position it by the pre-punched holes and 10mm long self tapping screws. Note this channel is fitted with the flat face uppermost, ie. nearest the “top”.

#### 8.4. ASSEMBLE THE ROOF PANEL

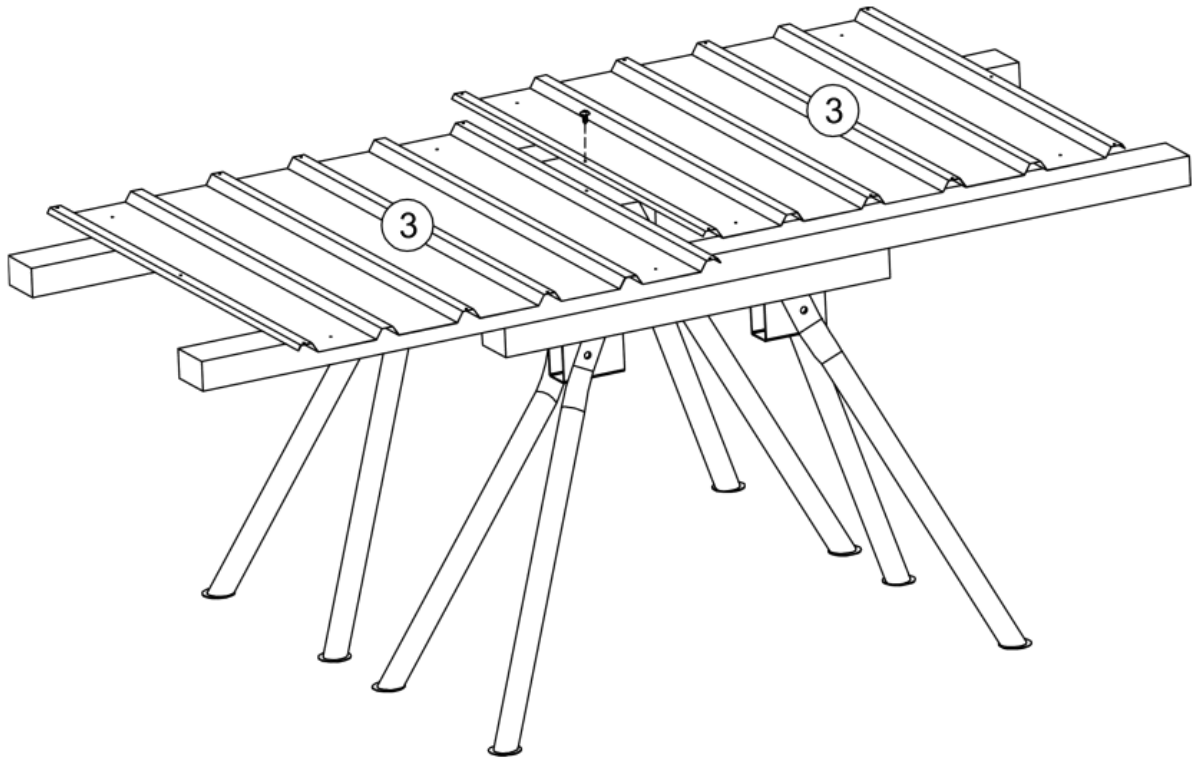

- 8.4.1. Place both panels item 3 on your work table and join them together with the 10mm long self tapping screws. See the pre-punched holes and both diagrams.
- 8.4.2. Fit top and bottom channels item 20A to panels by firstly sliding and finally tapping into place as previously explained in 8.1.3. Note that the smaller flange on the channels should always be adjacent to the outside face of the panel. The outside face is the top face in both diagrams.

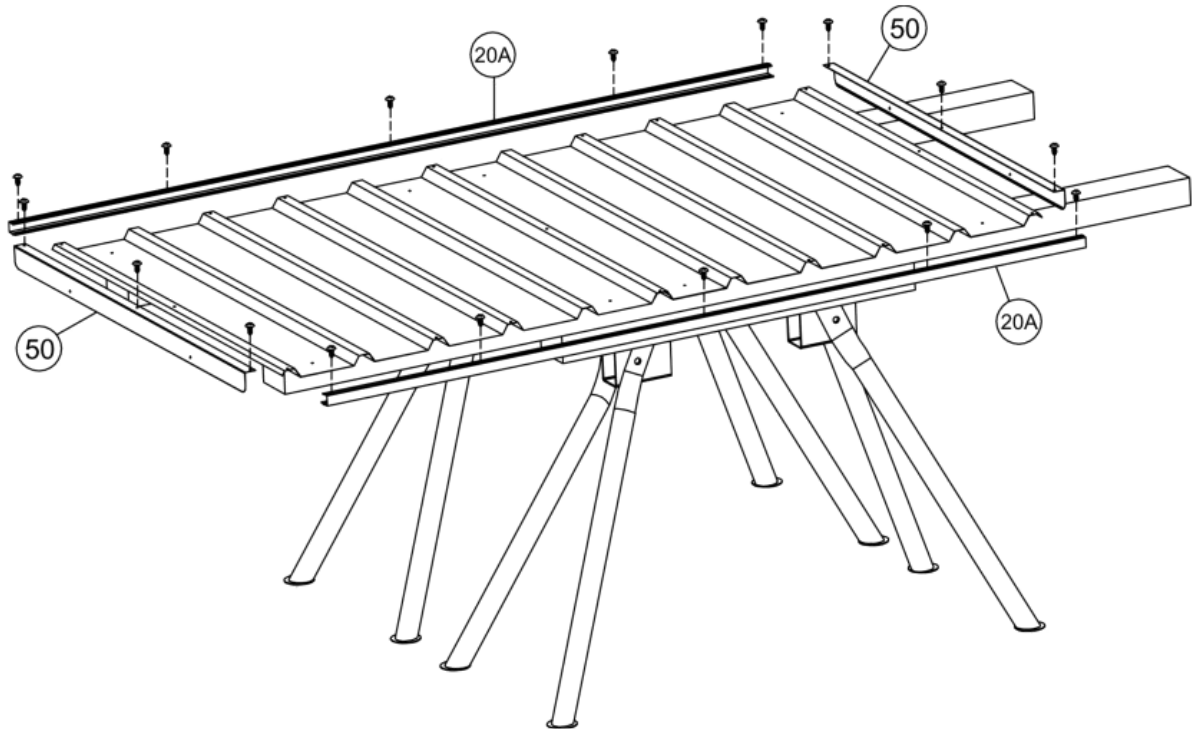

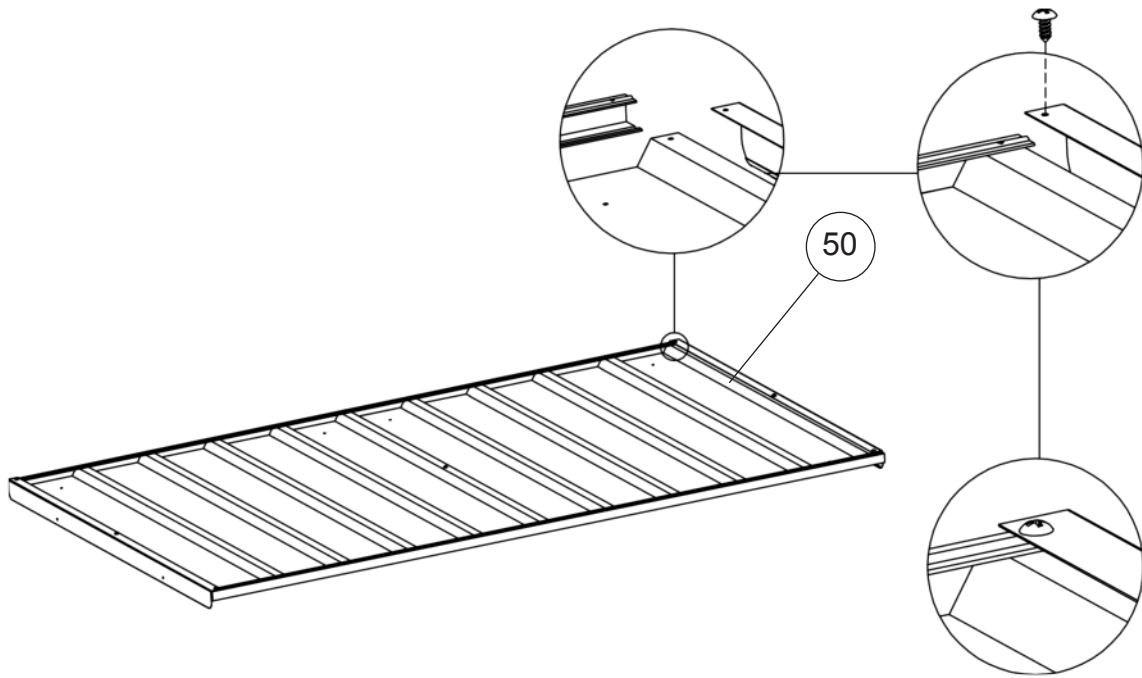

8.4.3. Fit item 50 (angles) to each edge, refer to diagram this page for flange orientation. Fix with 10mm long self tapping screws.

**8.5. FIT THE SUB ASSEMBLED REAR SIDE AND FRONT PANELS TOGETHER.**

8.5.1. Attach the side wall 2E to the rear wall 1A & 1L, then the front wall 9A & 9S. Fix all walls with the 10mm long self tapping screws.

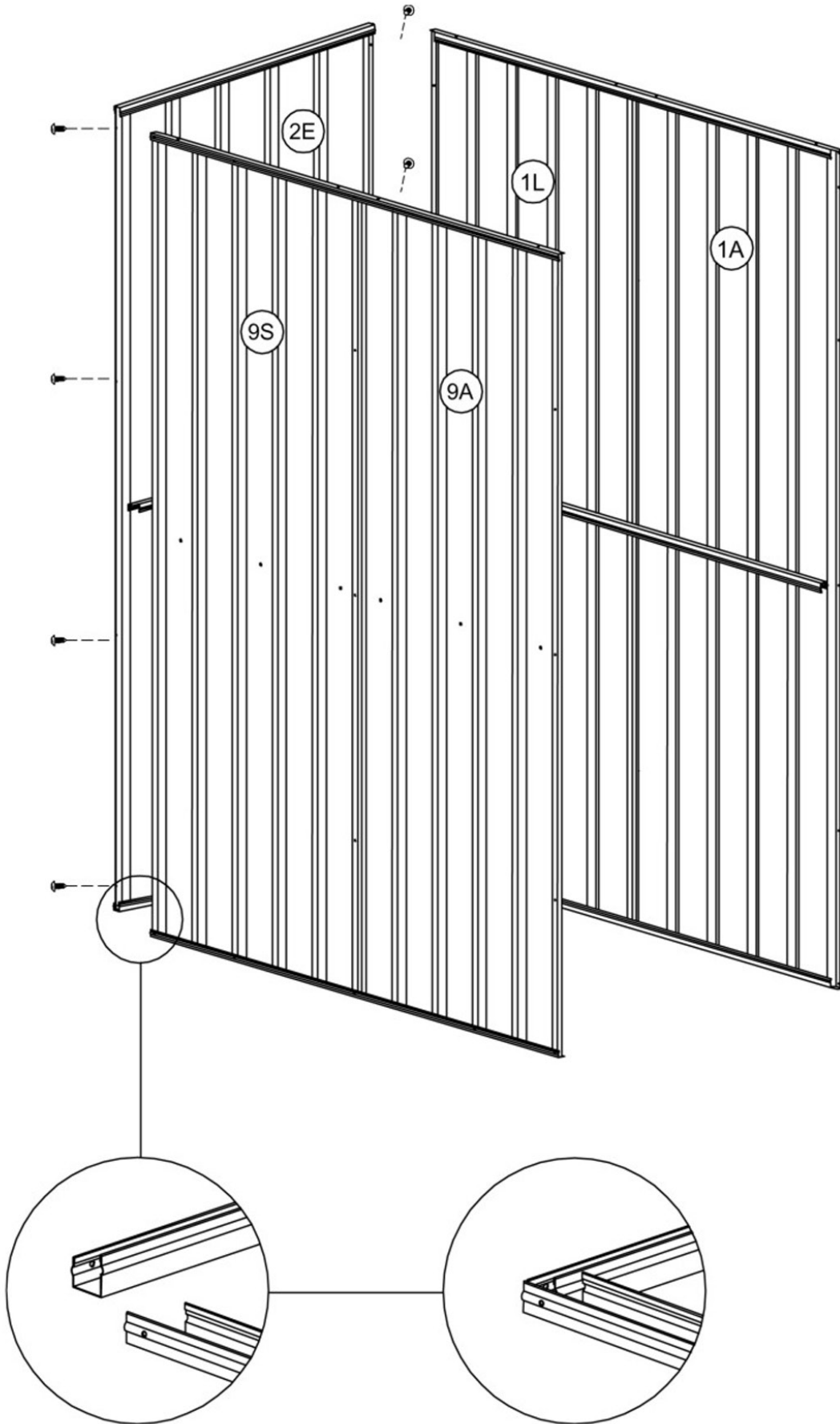

**8.6. INSTALL THE DOOR FRAME**

8.6.1. Install the front frame per following diagrams. The door mullion sections are fixed with 16mm long self tapping screws. Do not fix self tapping screws marked \* in enlarged ballooned views at this stage.

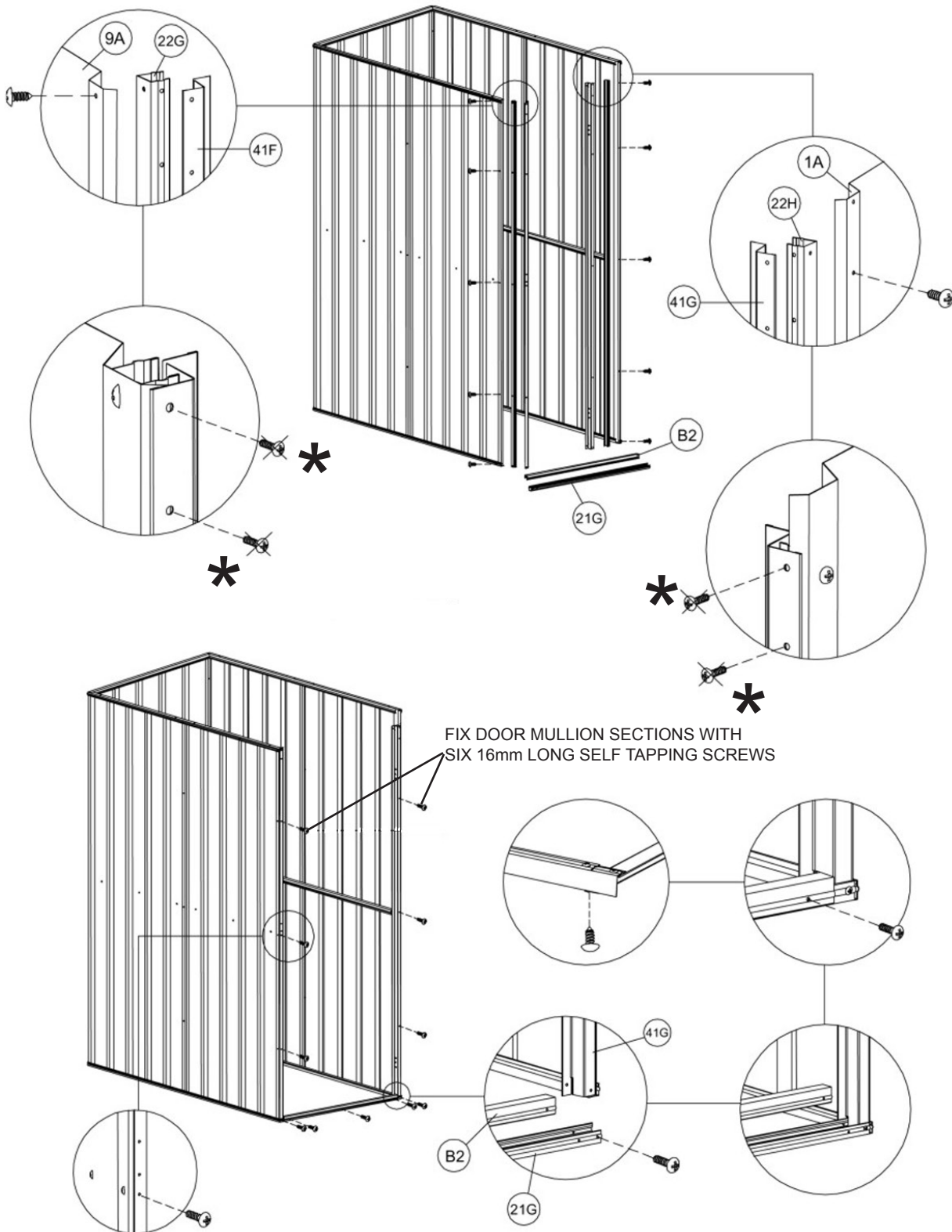

8.6.2. Fit the panel item 2F and the channel item 21H, fix with 16mm long self tapping screws.

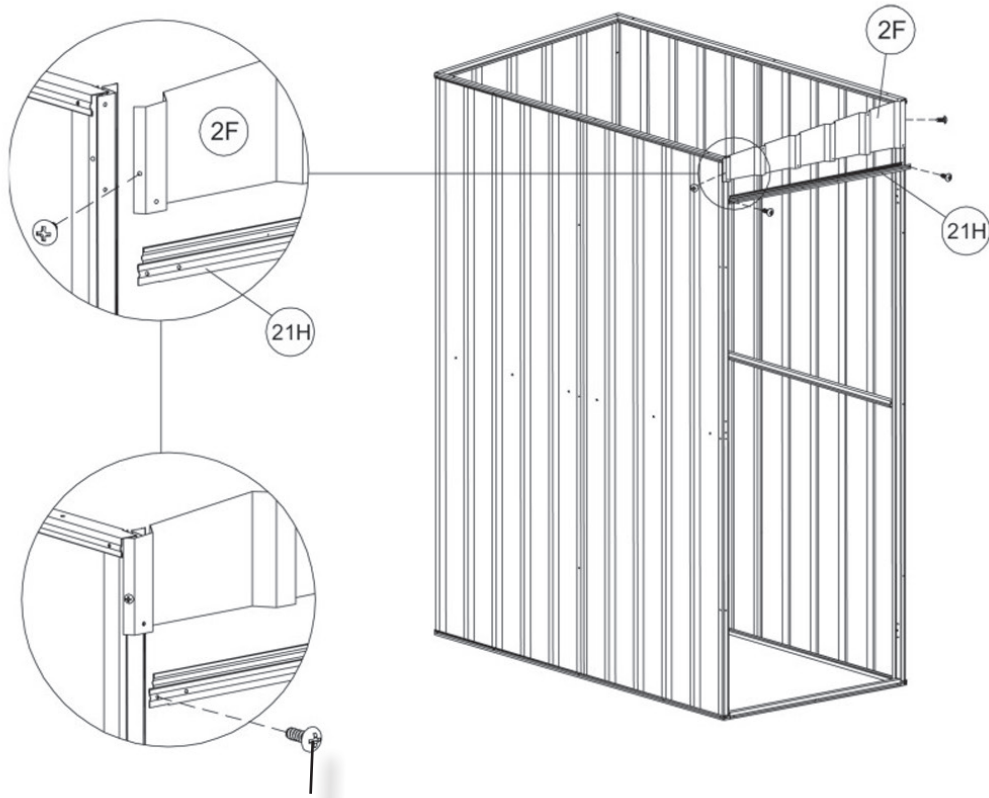

Fix the channel item 21H with 16mm long self tapping screws.

8.6.3. Slide and tap on top channel item 21J, but do not screw fix at this stage.

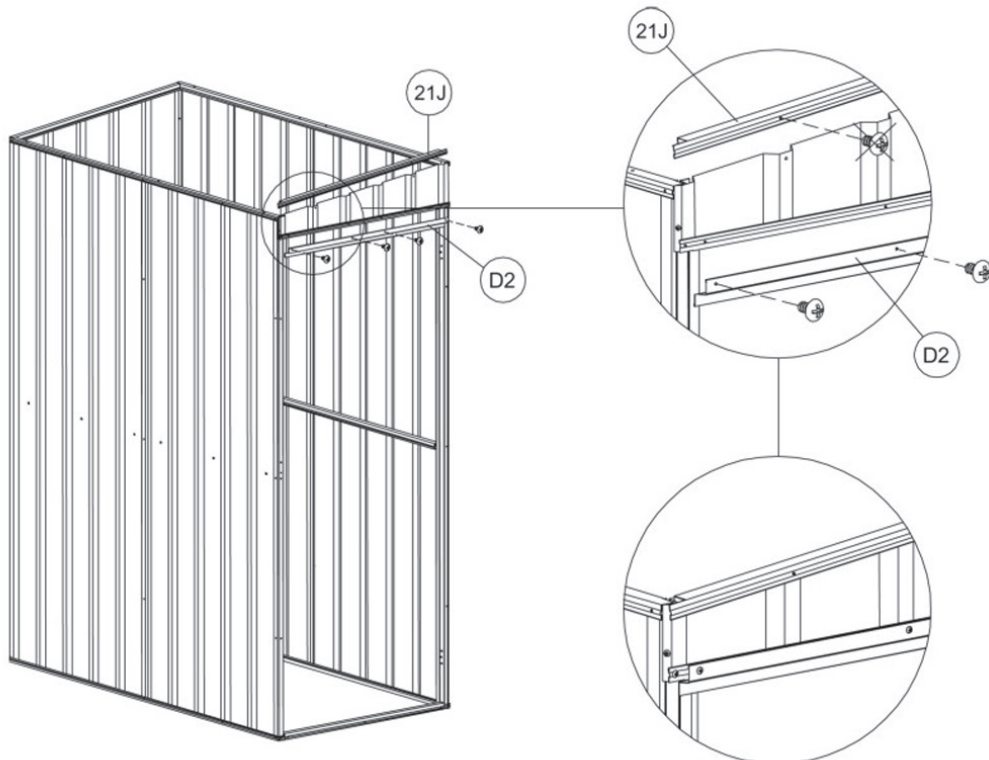

## 8.7. INSTALL THE DOOR

- 8.7.1 Fit the pre assembled door item 5C to the rear panel via the hinges. Fix hinges into pre-punched holes with 4mm diameter rivets. Check action of door before crimping rivets.
- 8.7.2 Fit the shoot bolt item 70 and the bolt keeper item 71 and fix with 10mm long self tapping screws or 4mm diameter rivets, (fitting method A or B)

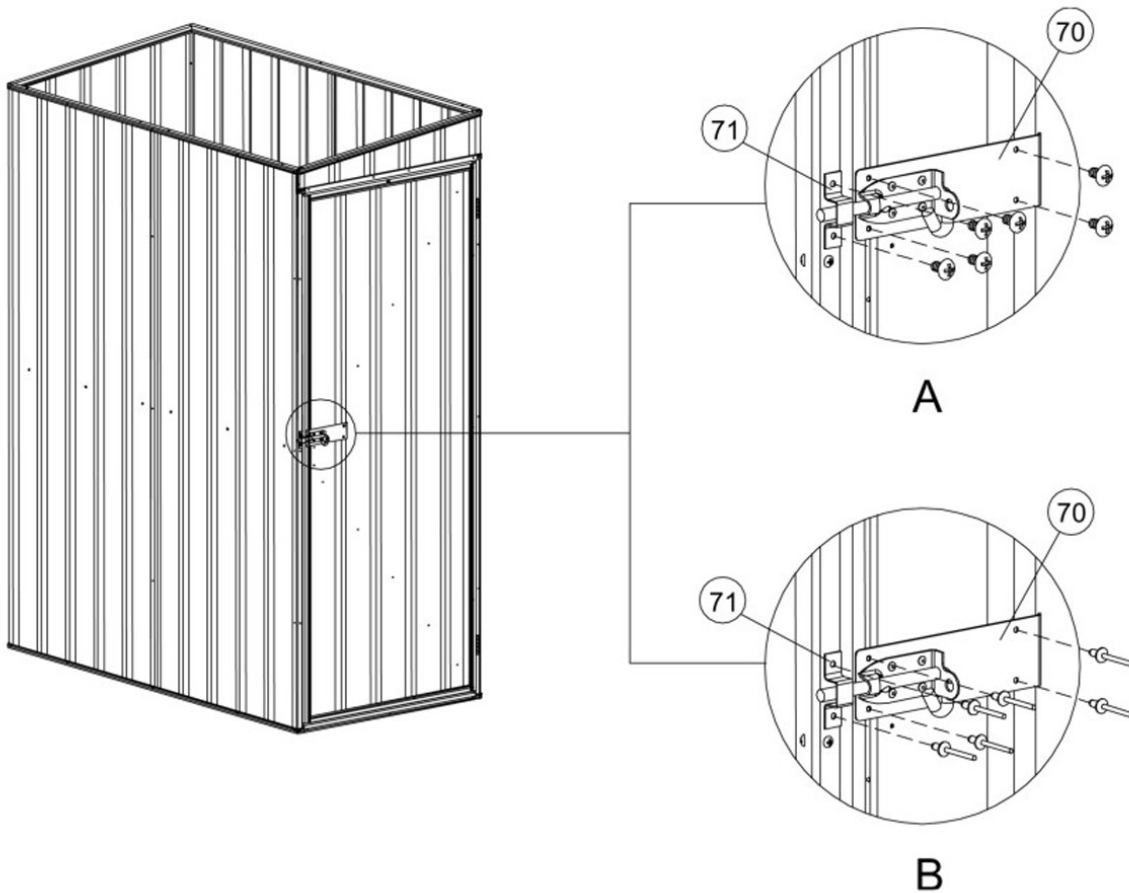
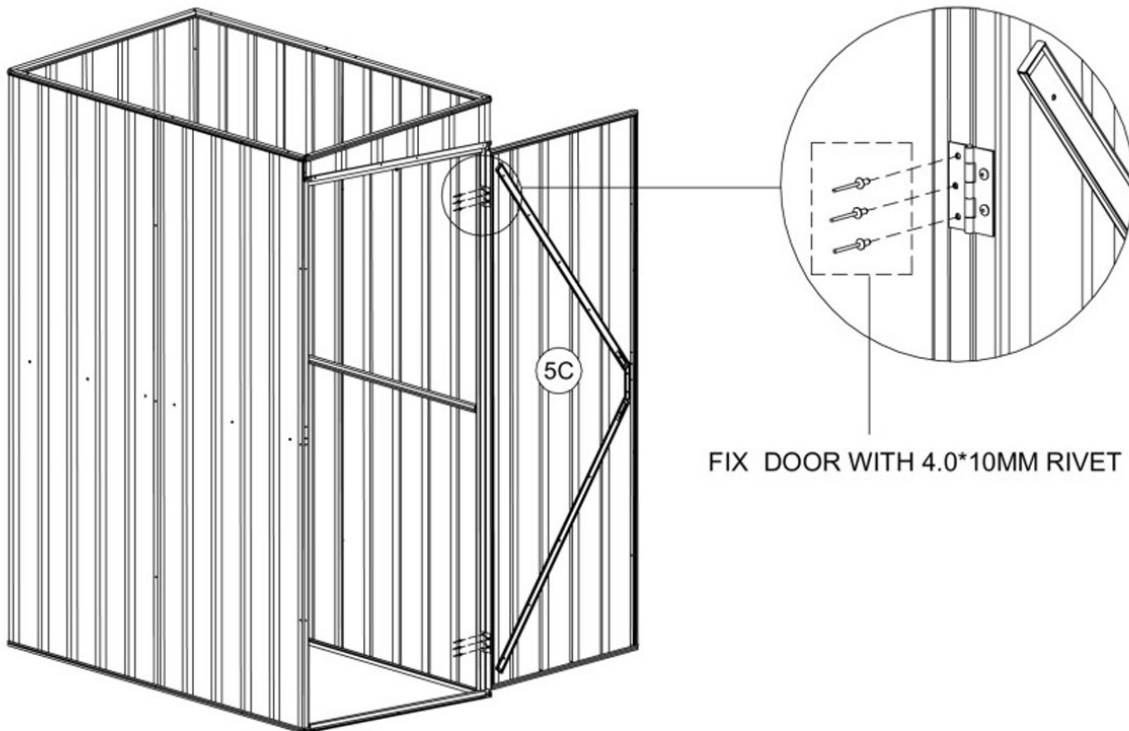



## 8.8. INSTALL THE ROOF

- 8.8.1. Self tapping screw fix the pre-assembled roof panel from 8.4.2; comprising items 3, 20A and 50.
- 8.8.2. With the shed located centrally about the plinth slab, position the 6 anchor steel angles, M8 machine screw fix to internal compartment. This will require "spotting" and drilling 8mm diameter holes through to shed panels. Spot through holes to plinth slab, remove anchor angles and masonry drill slab for anchor bolts. Please note anchor bolts and M8 machine screws are supplied, see "FITTINGS PACK".
- 8.8.3. Insert anchor bolts, re-fit steel angles and anchor shed to plinth slab.

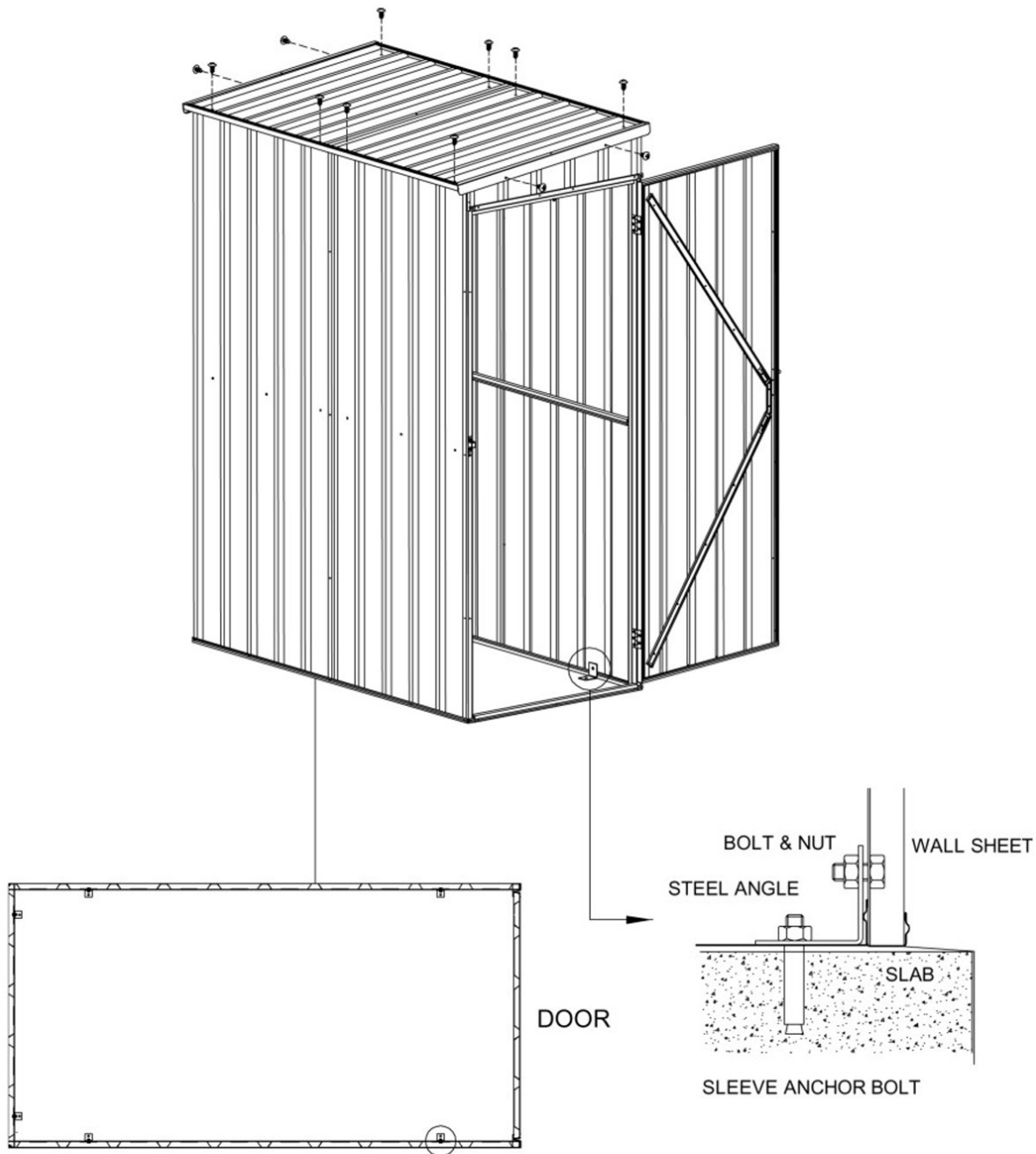

**8.9. SHED RIGIDITY AND USER SAFETY.**

- 8.9.1. For shed rigidity, self tapping screw fix the 2 mid height wall brace brackets, item 72.
- 8.9.2. Fit safety covers L to 38B and R to 38A and any projecting screws to be made safe with self taper covers.

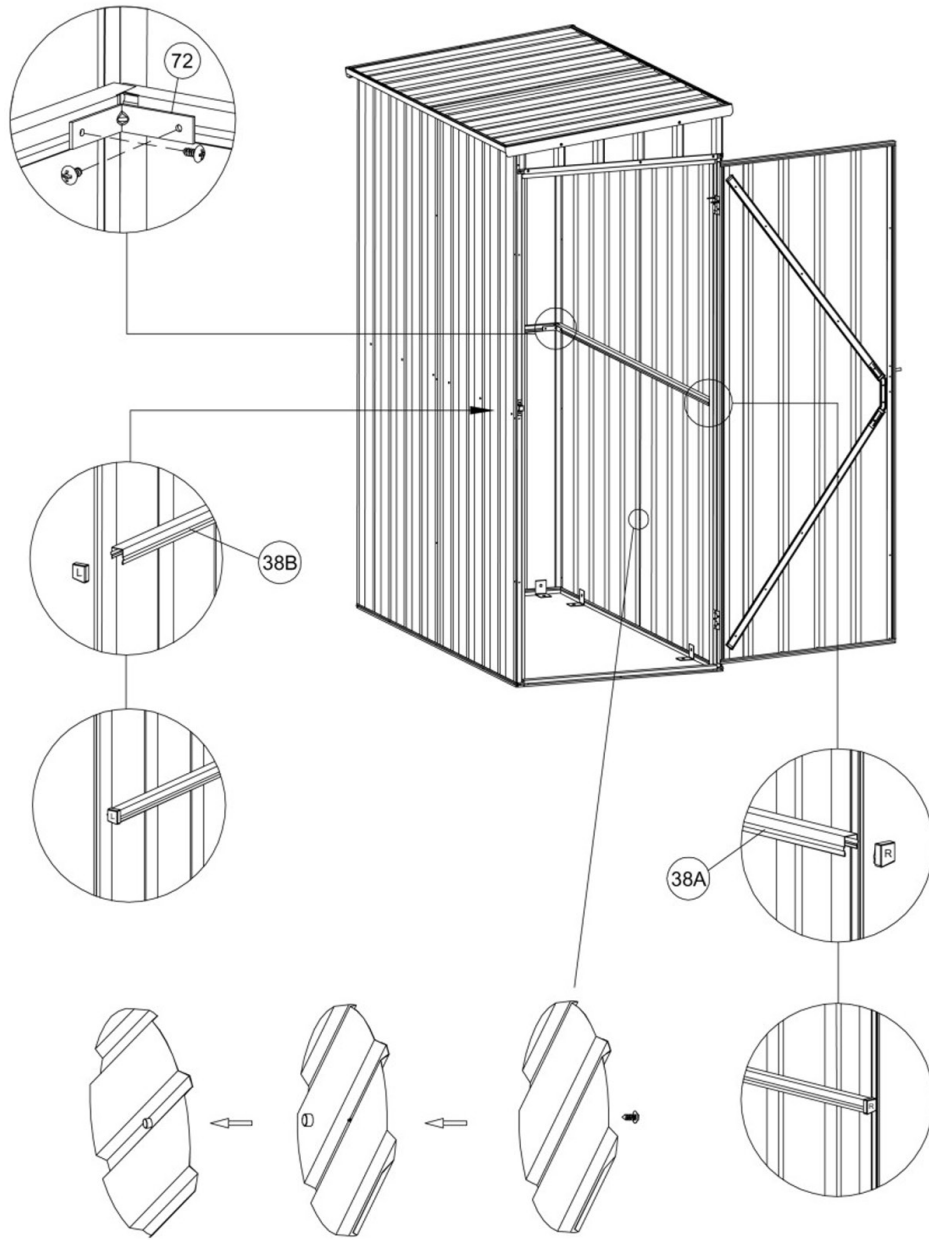

Parts support is available for this product. To obtain a parts listing and/or diagram, please log on to [www.sealey.co.uk](http://www.sealey.co.uk), email [sales@sealey.co.uk](mailto:sales@sealey.co.uk) or telephone 01284 757500.



**Environmental Protection**  
 Recycle unwanted materials instead of disposing of them as waste. All tools, accessories and packaging should be sorted, taken to a recycling centre and disposed of in a manner which is compatible with the environment. When the product becomes completely unserviceable and requires disposal, drain off any fluids (if applicable) into approved containers and dispose of the product and the fluids according to local regulations.

**NOTE:** It is our policy to continually improve products and as such we reserve the right to alter data, specifications and component parts without prior notice.



**IMPORTANT:** No liability is accepted for incorrect use of this product.



**WARRANTY:** Guarantee is 12 months from purchase date, proof of which will be required for any claim.

**INFORMATION:** For a copy of our latest catalogue and promotions call us on 01284 757525 and leave your full name and address, including postcode.



**Sole UK Distributor, Sealey Group,**  
 Kempson Way, Suffolk Business Park,  
 Bury St. Edmunds, Suffolk,  
 IP32 7AR

 01284 757500  
 01284 703534

 [www.sealey.co.uk](http://www.sealey.co.uk)  
 [sales@sealey.co.uk](mailto:sales@sealey.co.uk)