

1/2" Air Composite Impact Wrench(Twin Hammer)

Model No.:BW-112F (BW-112E,BW-112B,BW-112J),

BW-112F2 (BW-112E2,BW-112B2,BW-112J2)

BW-134F1(BW-134E1,BW-134B1,BW-134J1)

INSTRUCTION MANUAL



IMPORTANT:

Upon receipt of the product, read and follow all safety rules, operating instructions before first use it. And retain this manual for future reference.



Contain:

- ⊙ Technical Data
- ⊙ Important safety rules
- ⊙ Operating Instructions
- ⊙ Maintenance
- ⊙ Trouble Shooting
- ⊙ Parts List

※ Technical Data

Square drive.....	1/2"/13mm
Free speed.....	8,500rpm
Working Torque	737.5 ft-lbs/1000N.M)
Working Torque (BW-134F1).....	811ft-lbs/1100 N.M)
Max Loosening torque in Reverse.....	1100ft/lb(1492N.m)
Max Loosening torque in Reverse(BW-112F2).....	1062ft/lb(1442N.m)
Max Loosening torque in Reverse(BW-134F1).....	1150ft/lb(1560N.m)
Avg. air consumption.....	6.cfm (170 L/min)
Standard Operating pressure.....	90psi(6.3bar)
Air inlet size.....	1/4"(6.35mm)
Air Hose (ID).....	3/8" (10 mm)
Weight.....	4.62Lbs (2.1 kgs)
Weight(BW-112F2).....	3.6Lbs(1.65 kgs)
Standard Bolt Capacity	5/8" (16mm)
EN ISO 15744:2008 & EN ISO 4871 & EN ISO 11148-6:2012	
A weighted sound pressure level.....	89.9dB(A), k=3dB(A)
Sound power level.....	100.9dB(A) , k=3dB(A)
ISO 28927-2 & EN 12096	
Vibration in the handle.....	6.847m/s ² ,k=1.5m/s ²

※ Important Safety Rules

1. Always wear safety goggles or glasses.
2. Always ensure machine is switched off before connecting to air supply.
3. Disconnect any machine from the air supply before changing blades or discs, and before servicing any type of machine.
4. Always keep your air tool clean and lubricated. Daily lubrication is essential to avoid internal corrosion and possible failure.
5. Do not wear watches, rings bracelets or loose clothing when using air tools.
6. Using only light weight coil hoses from a tool to the wall or compressor coupling. Do not fit quick change couplings onto the machine as vibration can cause the coupling to fail.
7. Do not overload the machine. Allow the tool to operate at its optimum speed for maximum efficiency.
8. Do not increase the air pressure above the manufacturers recommended level, as excessive overload can cause the machine casing to split. Also this creates excessive wear on moving parts and possible failure.
9. In the interests of safety and possible damage to the machine/operator, always ensure that the machine has stopped before putting it down after use.
10. Always ensure that the workpiece is firmly secured leaving both hands free to control the machine.
11. Always ensure that the accessories such as blades, discs, sockets, etc. are designed for use with the machine. Also correctly and securely fastened before connecting the machine to the air supply.
12. When grinding, sanding or cutting always wear an appropriate face mask or respiratory equipment.

※ Operating Instruction

Description

1/2" twin hammer mechanism composite air impact wrench, working torque for most of automotive repairing job or garage working;1492 N.M of ultimate max loosening torque in reverse, twin hammer mechanism is durable and quickly remove stubborn bolts under tough working conditions,Sealed in oil bath lubrication keeps impact mechanism lubricated for less wear, Robust Fiberglass reinforced composite housing helps insulate users' hand from cold and Reduce vibration for less user fatigue, 6 vane rotor provides faster motor start up and greater performance with high torque,Three torque setting in forward, Full Power torque in reverse, Full teasing trigger for improved operator control, best power to weight ratio in economic cost.

Air supply

1. Ensure wrench air valve (or trigger) is in the "off" position before connecting to the air supply.
2. You will require an air pressure of 90psi, and an air flow according to specification.
3. **WARNING!** Ensure the air supply is clean and does not exceed 90psi while operating the wrench.

Too high an air pressure and unclean air will shorten the product life due to excessive wear, and may be dangerous causing damage or personal injury.

4. Drain the air tank daily. Water in the air line will damage the wrench.
5. Clean air inlet filter weekly.
6. Line pressure should be increased to compensate for unusually long air hoses (over 8 metres). The minimum hose diameter should be 3/8" I.D. and fittings must have the same inside dimensions.
7. Keep hose away from heat, oil and sharp edges. Check hose for wear, and make certain that all connections are secure.

Lubrication

An automatic in-line filter-regulator-lubricator is recommended (Fig4) as it increases tool life and keeps the tool in sustained operation. The in-line lubricator should be regularly checked and filled with air tool oil.

Proper adjustment of the in-line lubricator is performed by placing a sheet of paper next to the exhaust ports and holding the throttle open approximately 30 seconds. The lubricator is properly set when a light stain of oil collects on the paper. Excessive amounts of oil should be avoided.

In the event that it becomes necessary to store the tool for an extended period of time (overnight, weekend, etc.), it should receive a generous amount of lubrication at that time. The tool should be run for approximately 30 seconds to ensure oil has been evenly distributed throughout the tool. The tool should be stored in a clean and dry environment.

- It is most important that the tool be properly lubricated by keeping the air line lubricator filled and correctly adjusted. Without proper lubrication the tool will not work properly and parts will wear prematurely.
- Use the proper lubricant in the air line lubricator. The lubricator should be of low air flow or changing air flow type, and should be kept filled to the correct level. Use only recommended lubricants,

specially made for pneumatic applications. Substitutes may harm the rubber compounds in the tools O-rings and other rubber parts.

IMPORTANT!!!

If a filter/regulator/lubricator is not installed on the air system, air operated tools should be lubricated at least once a day or after 2 hours work with 2 to 6 drops of oil, depending on the work environment, directly through the male fitting in the tool housing.

Fig 4.

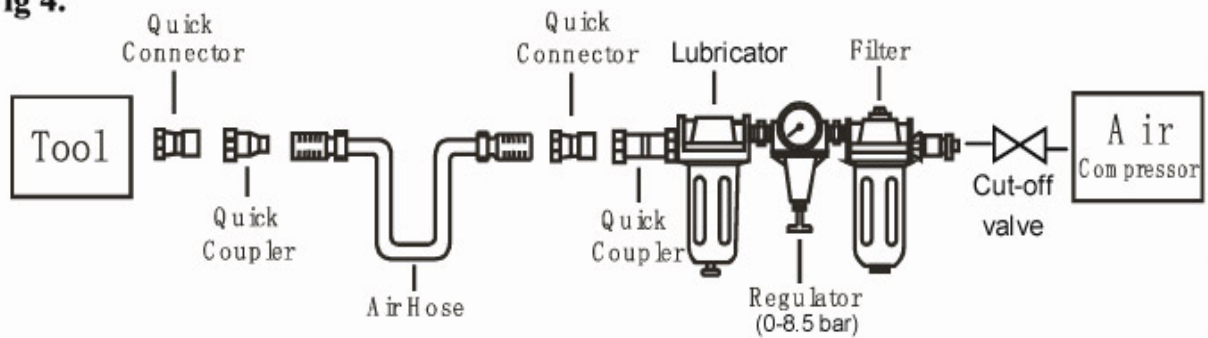

Assembly, Loading and operation

⚠️WARNING: Ensure you read, understand and apply safety instructions before use.

As a standard practice, drain water from the air compressor tank and air lines prior to use each day (reference your compressor operators manual for detailed instructions)

1. Remove the air inlet protective cap (Fig 1)
2. Thread the male plug by hand into the inlet bushing (Fig 2)
male plug should have seal tap on its male threads.
3. Add 2-3 drops oil into male plug before each use (Fig 3)
4. Connect to air source with quick coupler (Fig 4)
5. Insert the sockets on socket retainer (Fig 5)

Attention: Only use sockets which are specifically designed for use with this tool.

6. One thing shall make sure the direction of rotation before actuate this tool.
The Three Circles indicates Forward and the One Circle indicates reverse. Forward is defined as clockwise direction seen from the operator's position. (FIG 6)
7. Torque adjusting: Forward torque have 3 steps (small circles to big circles) on right side with Three Circles mark; Reverse torque have only one step on left side with One Circle mark (FIG 6)

DO NOT use any additional force upon the tool in order to work
DO NOT allow tool to free run for an extended period of time
as this will shorten its life.

Turn on the air compressor and allow it to build up pressure once all of jobs done. Adjust the air compressor's regulator or the supply line regulator to 90PSI. Squeeze trigger gently.

FIG 6



FIG1

FIG2

FIG3

FIG4

FIG5



⚠️WARNING: Disconnect wrench from air supply before changing accessories, servicing or performing maintenance. *Replace or repair damaged parts. Use genuine parts only. Non-authorized parts may be dangerous*

1. Lubricate the air wrench daily with a few drops of air tool oil dripped into the air inlet
2. DO NOT use worn, or damaged sockets.
3. Loss of power or erratic action may be due to the following:
 - a) Excessive drain on the air line. Moisture or restriction in the air pipe. Incorrect size or type of hose connectors. To remedy check the air supply and follow instructions .
 - b) b) Grit or gum deposits in the wrench may also reduce performance. If your model has an air strainer (located in the area of the air inlet), remove the strainer and clean it..
4. When not in use, disconnect from air supply, clean wrench and store in a safe, dry, childproof location.

⚠️WARNING: before you store air impact wrench after working, please add 2 to 3 drops oil into tools,run the tools for 25 to 30 seconds after lubricating, it will ensure the oil lubrications will be distributed through out the tools completely,

⚠️WARNING: when you assembly tools,please make sure rear4 bolts (Right picture) will be tighten equally through Plum blossom head rice type hands wrench.



※ **Trouble Shooting**

The following form lists the common operating system with problem and solutions. Please read the form carefully and follow it.

⚠️WARNING: If any of the following symptoms appears during your operating, stop using the tool immediately, or serious personal injury could result. Only a qualified persons or an authorized service center can perform repairs or replacement of tool.

Disconnect tool from air supply before attempting repair or adjustment. When replacing O-rings or Cylinder, lubricate with air tool oil before assembly.

PROBLEMS	POSSIBLE CAUSES	REMEDIES
Tool runs at normal speed but loses under load	<ul style="list-style-type: none"> ■. Motor parts worn. ■ Cam clutch worn or sticking due to lack of lubricant. 	<p>GREASE LUBRICATED:</p> <ul style="list-style-type: none"> ■Lubricate clutch housing. ■ Check for excess clutch oil. Clutch cases need only be half full. Overfilling can cause drag on high speed clutch parts, ie. a typical oiled/lubricated torque wrench requires 1/2 ounce of oil. <p>NOTE: Heat usually indicates insufficient grease in chamber. Severe operating conditions may require more frequent lubrication.</p> <p>Have a qualified service technician replace the worn motor parts.</p>

<p>Tool runs slowly. Air flows slightly from exhaust</p>	<ul style="list-style-type: none"> ■ Motor parts jammed with dirt particles ■ Power regulator in closed position ■ Air flow blocked by dirt. 	<ul style="list-style-type: none"> ■ Check air inlet filter for blockage. ■ Pour air tool lubricating oil into air inlet as per instructions. ■ Operate tool in short bursts quickly reversing rotation back and forth where applicable. ■ Repeat above as needed.
<p>Tools will not run. Air flows freely from exhaust</p>	<ul style="list-style-type: none"> ■ One or more motor vanes stuck due to material build up. 	<ul style="list-style-type: none"> ■ Pour air tool lubricating tool into air inlet. ■ Operate tool in short bursts of forward and/or reverse rotation where applicable. ■ Tap motor housing gently with plastic mallet. ■ Disconnect supply. Free motor by rotating drive shank manually where applicable
<p>Tool will not shut off</p>	<ul style="list-style-type: none"> ■ 'O' rings throttle valve dislodged from seat inlet valve. 	<ul style="list-style-type: none"> ■ Replace 'O' ring.
<p style="text-align: center;">Note: Repairs should be carried out by a qualified person.</p>		

Spare Parts Drawing

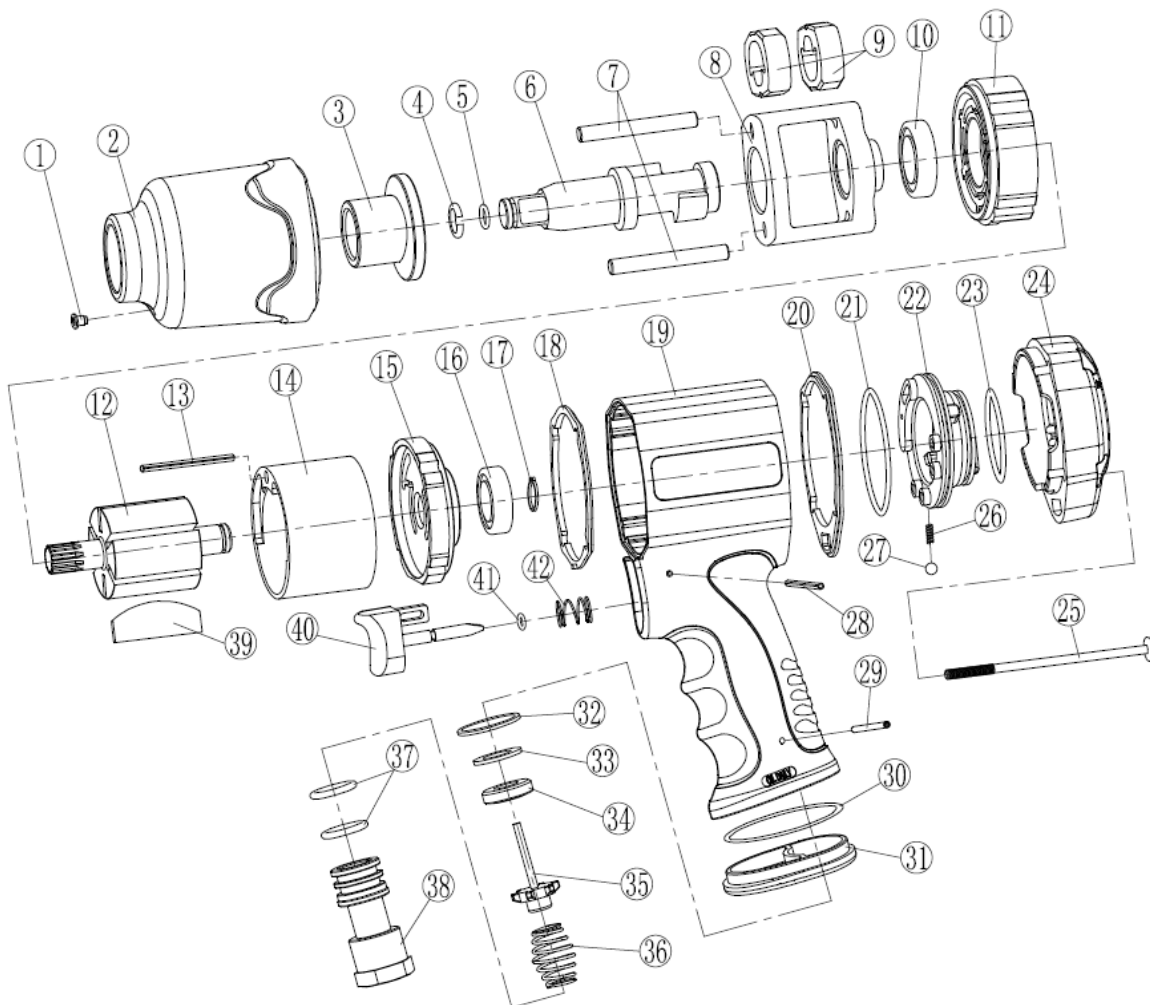

Parts List

Sep 27th,2018

NO.	ASSY NO.	DESCRIPTION	Q'TY	NO.	ASSY NO.	DESCRIPTION	Q'TY
1	A	Press-Oiling Cup	1	25		End cap screw	1
2	A	Hammer Case	1	26	E	Steel ball spring	1
3	A	Bushing	1	27	E	Steel Ball	1
4	B	Retainer	1	28	D	Trigger Pin 2.5x2.4	1
5	B	O-ring	1	29	D	Pin 2.5x30	1
6	B	Anvil	1	30	D	O-ring 3x1	1
7	B	Hammer Pin	1	31	D	Exhaust Deflector	1
8	B	Hammer Frame	1	32	D	Washer	1
9	B	Hammer Dog	2	33	D	Intake Gasket	1
10	C	Bearing	1	34	D	Throttle valve	1
11	C	Front Cylinder Plate	1	35	D	Throttle	1
12	C	Rotor	1	36	D	Throttle Spring	1
13	C	Pin	1	37	D	O-ring	2
14	C	Cylinder	1	38	D	Air inlet	1
15	C	Rear Cylinder Plate	1	39	C	Rotor Blade	6
16	C	Bearing	1	40	D	Trigger	1
17	D	Gasket	1	41	D	O-ring 3x1	1
18		Front Seal washer	1	42	D	Trigger Spring	1
19	D	Housing	1				
20	E	Rear Seal Washer	1	NS-A		Hammer Case Kit	1
21	E	O-ring	1	NS-B		Anvil Kit	1
22	E	Reverse Switch	1	NS-C		Cylinder Kit	1
23	E	O-ring 52.7 x 1.8mm	1	NS-D		Housing Kit	1
24	E	End cap	1	NS-E		Rear Cover Kit	1

EC DECLARATION OF CONFORMITY

DECLARAÇÃO CE DE CONFORMIDADE

Manufacturer : Taizhou Beswell Machinery Co.,Ltd.
(Fabricante)
: JingQi Road,Economic Development Zone,Taizhou
(Morada) ZHEJIANG,CHINA

Declares, that the product(s)
Declara que os produtos

Product Name : AIR IMPACT WRENCH
(Nome do produto)

Model Number(s) : BW-112F,BW-112E, BW-112B, BW-112E2, BW-112F2, BW-112B2, BW-112E3,
BW-112F3, BW-134E1, BW-134F1, BW-134B1, BW-134E2, BW-134F2, BW-134B2,BW-112J, BW-112M,
BW-134H, BW-112K, BW-112N2, BW-112X, BW-134N, BW-112V, BW-112S, BW-112U, BW-134J,
BW-134K,BW-112C

Conform(s) the following standarts and/or product specifications,
Estão em conformidade com as seguintes normas

Relevant Standard(s) : EN ISO 11148-6:2012
Hand-held Non-electric Power Tools-Safety Requirements-
Part 6: Assembly power tools for threaded fasteners
Specification(s)/Directive(s) ZEK01.04-08/11.11
the Machinery Directive 98/37/EC
the Machinery Directive 2006/42/EC

Date : 23 / April / 2018

Authorized Signature :
(Assinatura)

Taizhou Beswell Machinery Co.,Ltd