



# GARDEN HOSE TROLLEY 60M CAPACITY

MODEL NO: **GH60.V2**

Thank you for purchasing a Sealey product. Manufactured to a high standard, this product will, if used according to these instructions, and properly maintained, give you years of trouble free performance.



**IMPORTANT:** PLEASE READ THESE INSTRUCTIONS CAREFULLY. NOTE THE SAFE OPERATIONAL REQUIREMENTS, WARNINGS & CAUTIONS. USE THE PRODUCT CORRECTLY AND WITH CARE FOR THE PURPOSE FOR WHICH IT IS INTENDED. FAILURE TO DO SO MAY CAUSE DAMAGE AND/OR PERSONAL INJURY AND WILL INVALIDATE THE WARRANTY. KEEP THESE INSTRUCTIONS SAFE FOR FUTURE USE.

## 1. SAFETY

- ❑ **WARNING!** Disconnect the hose reel from the water supply before changing accessories, servicing or performing any maintenance.
- ✓ Maintain the hose reel trolley in good condition.
- ✓ Replace or repair damaged parts. *Use recommended parts only. Unauthorised parts may be dangerous and will invalidate the warranty.*
- ✗ **DO NOT** operate the hose reel trolley if any parts are damaged or missing as this may cause failure and/or personal injury.
- ✗ **DO NOT** exceed the rated capacity of the hose reel trolley.
- ✗ **DO NOT** use the hose reel trolley for any purpose other than that for which it is designed.
- ✗ **DO NOT** operate the hose reel when you are tired or under the influence of alcohol, drugs or intoxicating medication.
- ✗ **DO NOT** direct water from the water hose at yourself or others.

## 2. INTRODUCTION

Lightweight tubular steel frame with tough plastic snap-together parts - no tools required. Fitted with two composite wheels for easy manoeuvrability and two angled 1/2" hose connectors. Reel holds up to 60m of Ø13mm hose.

## 3. SPECIFICATION

Model No:..... **GH60.V2**  
 Hose Capacity:..... 60m x Ø13mm  
 Inlet/Outlet Diameter: ..... 13mm

## 4. CONTENTS

4.1. Check parts against the parts list below. If anything is missing, contact your Sealey stockist.

NO.	DESCRIPTION	QTY
1	Left Hand Side Stand Holder	1
2	Right Hand Side Stand Holder	1
3	Handle	1
4	Stand	1
5	Axle	1
6	Reel End	2
7	Wheel	2
8	Wheel Cover	2
9	Reel Cross Piece	2
10	Crank Handle	1
11	Crank Handle Nut	1
12	Fixed Hose Connection	1
13	Angled Hose Connection	1

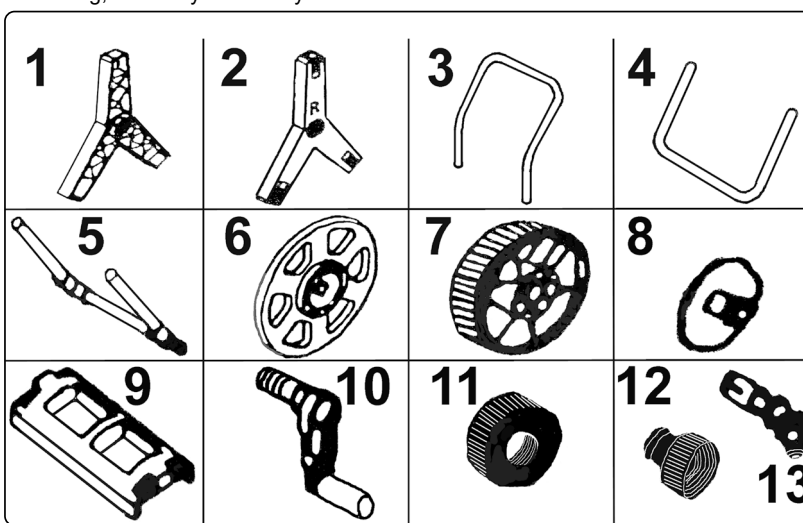

**NOTE: HOSE REEL NOT INCLUDED.**

## 5. ASSEMBLY

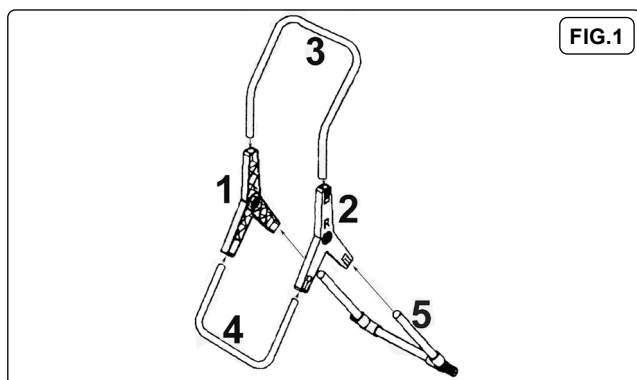

### 5.1. ASSEMBLING THE FRAME (FIG.1)

- 5.1.1. Attach the handle (3) to the left hand side stand holder (1) and the right hand side stand holder (2). Ensure that the embossed letters on each of the stand holders (1 & 2) are facing outermost and the letters are upright.
- 5.1.2. Attach the axle (5) to the stand holders (1 & 2).
- 5.1.3. Attach the stand (4) to the stand holders (1 & 2).

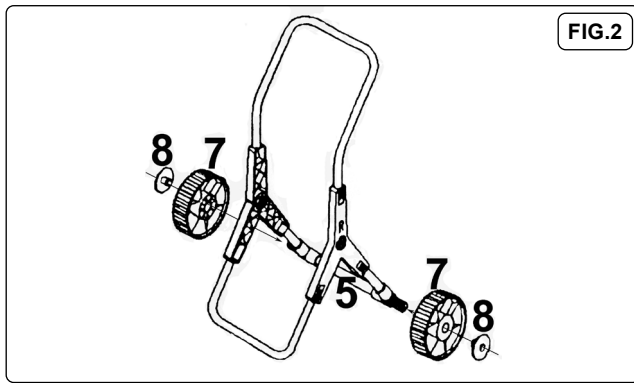

## 5.2. ATTACHING THE WHEELS (FIG.2)

- 5.2.1. Fit the wheels (7) to the axle (5) and secure by pressing the wheel covers (8) into the axle.

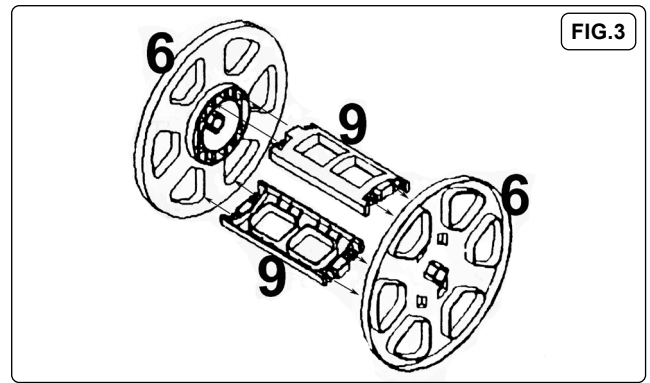

## 5.3. ASSEMBLING THE REEL (FIG.3)

- 5.3.1. Locate the reel cross pieces (9) into the slots in the reel ends (6) and push into place until they lock in position.

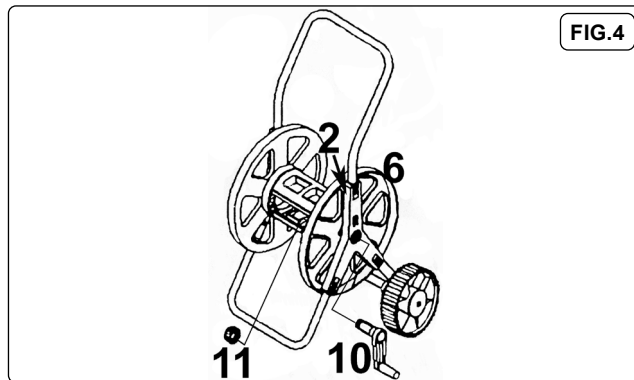

## 5.4. ATTACHING THE CRANK HANDLE (FIG.4)

- 5.4.1. Fit the crank handle (10) through the right hand side stand holder (2) and through the reel end (6) so that the threaded portion protrudes from the reel end (6).  
5.4.2. Screw the crank handle nut (11) onto the threads of the crank handle (10) and tighten.

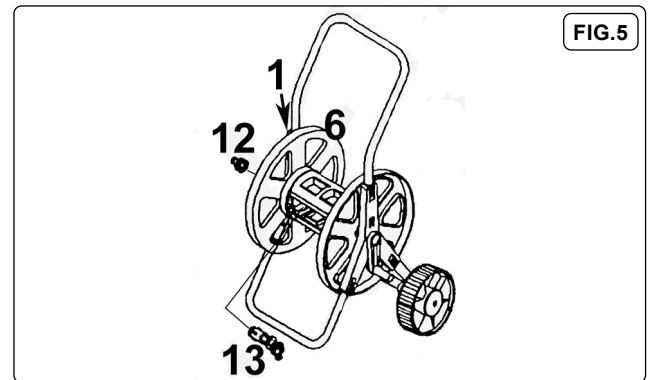

## 5.5. ATTACHING THE HOSE CONNECTIONS (FIG.5)

- 5.5.1. Fit the angled hose connection (13) through the reel end (6) and the left hand side stand holder (1) so that the threaded portion protrudes from the left hand side stand holder (1).  
5.5.2. Screw the fixed hose connection (12) onto the threads of the angled hose connection (13) and tighten. The hose trolley is now ready for use.

## 6. OPERATION

### 6.1. FITTING THE HOSE (NOT INCLUDED)

- 6.1.1. Attach the hose to the angled hose connection (13), and wind it onto the reel taking care to guide the hose from one side of the reel to the other to prevent bunching of the hose.  
6.1.2. Attach the supply hose to the fixed hose connection (12).

### 6.2. EXTENDING THE HOSE

- 6.2.1. Firmly hold the trolley and pull the hose from the reel. Pulling the hose directly from the reel may cause the hose trolley to tip over.

### 6.3. RETRACTING THE HOSE

- 6.3.1. When retracting the hose, always make sure the water supply is turned off, make sure there is plenty of space to perform the task. Free the hose's path of any obstructions and check for kinks in the hose before reeling in.  
6.3.2. Rotate the crank handle (10) clockwise whilst firmly holding the trolley taking care to guide the hose from one side of the reel to the other to prevent bunching of the hose.

## 7. STORAGE

- 7.1. Prior to storing the hose and reel, ensure that the water supply is turned off and any accessories are disconnected.  
7.2. Drain as much water from the hose as possible.  
7.3. Place in a dark, safe, dry, childproof location, where the hose will be protected from frost.



### ENVIRONMENT PROTECTION

Recycle unwanted materials instead of disposing of them as waste. All tools, accessories and packaging should be sorted, taken to a recycling centre and disposed of in a manner which is compatible with the environment. When the product becomes completely unserviceable and requires disposal, drain any fluids (if applicable) into approved containers and dispose of the product and fluids according to local regulations.



REGISTER YOUR PURCHASE HERE

**Note:** It is our policy to continually improve products and as such we reserve the right to alter data, specifications and component parts without prior notice. Please note that other versions of this product are available. If you require documentation for alternative versions, please email or call our technical team on [technical@sealey.co.uk](mailto:technical@sealey.co.uk) or 01284 757505.

**Important:** No Liability is accepted for incorrect use of this product.

**Warranty:** Guarantee is 12 months from purchase date, proof of which is required for any claim.

Sealey Group, Kempson Way, Suffolk Business Park, Bury St Edmunds, Suffolk. IP32 7AR



01284 757500



[sales@sealey.co.uk](mailto:sales@sealey.co.uk)



[www.sealey.co.uk](http://www.sealey.co.uk)