

Thank you for purchasing a Sealey product. Manufactured to a high standard this product will, if used according to these instructions and properly maintained, give you years of trouble free performance.



**IMPORTANT: PLEASE READ THESE INSTRUCTIONS CAREFULLY. NOTE THE SAFE OPERATIONAL REQUIREMENTS, WARNINGS & CAUTIONS. USE THE PRODUCT CORRECTLY AND WITH CARE FOR THE PURPOSE FOR WHICH IT IS INTENDED. FAILURE TO DO SO MAY CAUSE DAMAGE AND/OR PERSONAL INJURY AND WILL INVALIDATE THE WARRANTY. PLEASE KEEP INSTRUCTIONS SAFE FOR FUTURE USE.**

### 1. SAFETY INSTRUCTIONS

#### 1.1 GENERAL SAFETY

- ❑ **WARNING!** Ensure Health & Safety, local authority, and general workshop practice regulations are adhered to when using this equipment.
- ✓ Maintain the wheel aligner in good condition (use an authorised service agent).
- ✓ Replace or repair damaged parts. Use genuine parts only. Non-authorized parts may be dangerous and will invalidate the warranty.
- ✓ Locate wheel aligner in a suitable working area, keep area clean and tidy and free from unrelated materials.
- ❑ **WARNING!** Use aligner on vehicles that are parked on level and solid ground.
- ✓ Keep the gauge clean to ensure accurate performance.
- ✗ **DO NOT** use outside in damp or wet weather conditions.
- ✗ **DO NOT** allow untrained persons to operate the aligner.
- ✗ **DO NOT** leave the aligner unattended.
- ❑ **WARNING!** When setting front end alignment on commercial vehicles never make adjustments to drop arms or interconnecting links. Doing so could result in serious tyre, wheel and steering problems.
- ❑ **WARNING!** The warnings, cautions and instructions contained within this document cannot cover all possible conditions and situations that may occur. It must be understood that common sense and caution are factors which cannot be built into this product, but must be applied by the operator.
- ✓ Any alignment changes deemed necessary as a result of using this equipment must be made strictly in accordance with the vehicle manufacturer's recommendations.

#### 1.2 LASER SAFETY

The GA70 utilises a Class II laser that emits low levels of visible radiation (i.e. wavelengths between 400 and 700 nanometres) which are safe for the skin but not inherently safe for the eyes. The Class II emission limit is set at the maximum level for which eye protection is normally afforded by natural aversion responses to bright light. Accidental eye exposure is therefore normally safe, although the natural aversion response can be overridden by deliberately staring into the beam, and can also be influenced by the use of alcohol or drugs.



- ❑ **WARNING! DO NOT** look or stare into the laser beam as permanent eye damage could result.
- ✗ **DO NOT** direct the laser beam at any person's (or animal's) eyes as eye damage could result. If the beam is obstructed by a person during use, release the contact switch immediately.
- ✗ **DO NOT** use the equipment while under the influence of alcohol, drugs or whilst on medication.
- ✓ Be aware that reflections of the laser beam from mirrors or other shiny surfaces can be as hazardous as direct eye exposure.

### 2. INTRODUCTION

Fast, simple and accurate alignment of both front and rear wheels. Optimises vehicle performance and set up after installation or modification of steering or suspension components. Simple and fast to use, it is ideal for the busy professional workshop and has a fast return on investment - potentially adding value to every steering or suspension job. This fully portable kit is also ideal for track-day set up for the enthusiast. Works on practically all cars and light

### 3. CONTENTS



The GA70 kit consists of: Mobile storage unit (see above)

- |                                 |                             |
|---------------------------------|-----------------------------|
| 1. Laser Measuring Head x 2     | 3. Steering Wheel Clamp     |
| 2. Alignment Assembly Flags x 2 | 4. Dished Turning Plate x 2 |

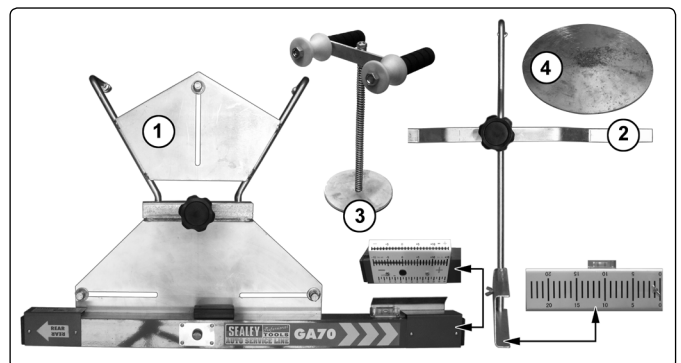

commercial vehicles with rim diameters between 320mm and 540mm. Supplied with steering wheel clamp, wheel turn plates and wheeled storage rack. Supplied with comprehensive operating instructions.

## 4. FOUR WHEEL ALIGNMENT

- 4.1. Accurate four wheel alignment should always take place with reference to the vehicles centre line to avoid problems similar the one shown in fig.1 where the vehicle will steer to the left resulting in the steering wheel having to be turned to the right to compensate. Basically, rear wheel tracking must be kept equal to the centre line and correctly toed in or out according to the vehicle manufactures specification in order for the vehicle to handle correctly. Check thrust lines are equal to centre line before proceeding.

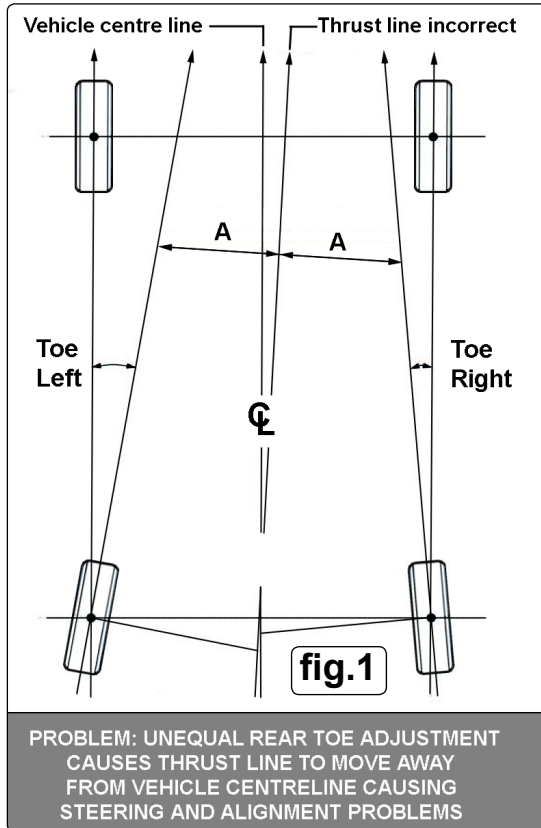

## 5. OPERATION

Prior to use, check that the tyre pressures are correct and if wheel covers are fitted, remove them. Ensure that the vehicle is on a smooth level surface with the wheels pointing straight ahead. **DO NOT** reverse the vehicle into position, but drive straight ahead into position. Ideally vehicle should be on a ramp or lift for easier access to the track rods, if adjustment is necessary.

### 5.1 FRONT TO REAR WHEEL ALIGNMENT.

- 5.1.1 Place both dished turn plates in front of the front wheels, with their curve facing downwards. Drive the vehicle onto the turn plates, ensuring they are central to the wheels (see fig.2).



- 5.1.2 Set steering wheel in straight ahead position and lock using the steering wheel clamp, (see fig.3).



- 5.1.3 Hang both laser measuring heads on the front wheels with toe scales positioned to the front of the vehicle, (see fig.4).

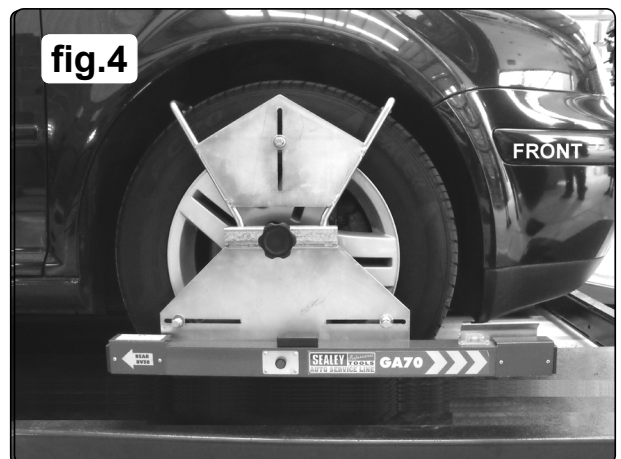

- 5.1.4 Hang the alignment assembly flags onto the top of the rear tyres and make adjustments, so that the horizontal bar is sitting at approximately the centre of the wheel and touching the tyre at both ends. Ensure that the scale is at 90° to the wheel. Check the spirit level to ensure the correct position is achieved, (see fig.5).



- 5.1.5 Turn on both front laser measuring heads. Now look to rear flags, refer to fig.6, you will have a reading on both sides, (the readings may not be the same). If you have two different readings on the rear flags, this means you now have to adjust both front track rod ends. You are now ensuring that the front wheels are in line with the rears.

The first step to achieving this, is to add both rear scale readings together and divide by 2.

For example:

N/S/R reading 2                      O/S/R reading 4 ( $2 + 4 = 6 \div 2 = 3$ )

You now need to adjust both front track rod ends until you achieve 3 on both rear flags.

## 5.2 CHECKING TOE ON FRONT WHEELS Refer to fig.7

- 5.2.1 Now that you have aligned front wheels with rear wheels, (using 5.1.5 instructions) you next have to check your toe readings on the front laser measuring head scales.

- 5.2.2 To obtain the toe, a small calculation is required. The reason for this is because you cannot ensure that both the O/S/F and N/S/F laser heads are positioned 100% equal to each other when fitted to the wheels.

### 5.2.3 Rules for calculation

If both lasers are hitting in the same colour zones, you have to add them together to obtain the vehicle's toe.

Example 1:

O/S/F Scale                      N/S/F Scale  
- 1 Red                              -2 Red (Your toe is currently -3 toe out)

Example 2:

O/S/F Scale    N/S/F Scale  
+ 1 Green      + 2 Green (Your toe is currently +3 toe in)

If the lasers are hitting in two different colour zones, you have to subtract the lesser number from the higher number.

Example 3:

O/S/F Scale    N/S/F Scale  
- 3 Red              + 4 Green (Your toe is currently + 1 toe in)

If the lasers are hitting in different colour zones but have equal readings, then the toe is 0.

Example 4:

## 5.3 ADJUSTING TOE

Now that you have obtained the vehicle's toe using 5.2 calculations, you may now need to adjust the toe according to the manufacturer's specifications.

When adjusting track rod ends, you must make sure you adjust equally on both sides. So if you adjust half a turn on the O/S/F then you must adjust half a turn on the N/S/F. Once you have obtained the desired toe, using the calculations, you must then check the rear flags to see whether they have equal readings on both sides.

**Please note:** If you have adjusted the toe then the rear flag reading will have changed from what you had originally set them to in step 5.1.5. If they are still equal then the job is complete.

If the rear flags are not equal then this would suggest you have not adjusted the O/S/F and N/S/F track rod ends equally when adjusting the toe, or the thrust angle is not equal on the rear wheels in relation to the centre line.

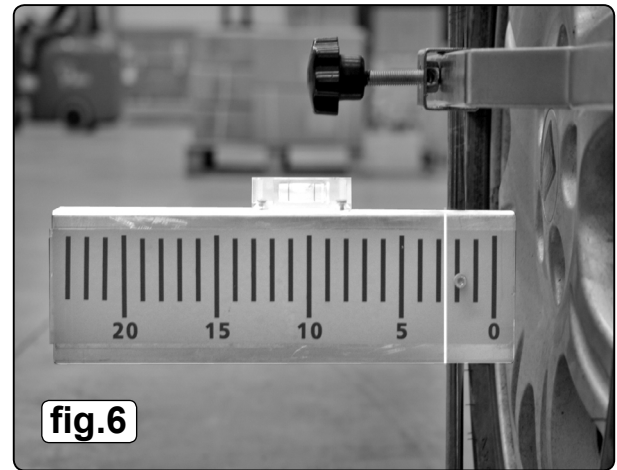

fig.6

RED SCALE = TOE OUT    ← | →    GREEN SCALE = TOE IN

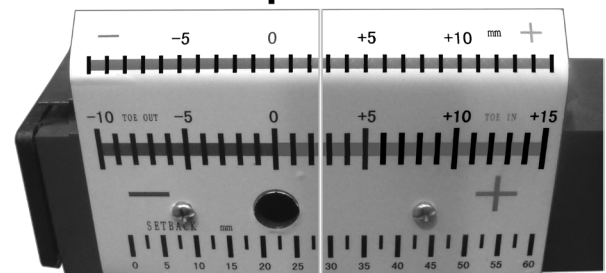

fig.7

SETBACK SCALE ALL BLACK

## 6. MAINTENANCE

- 6.1. After use, always secure all tools and measuring units back onto the mobile storage unit to minimise damage.
- 6.1.1. If a laser beam becomes difficult to see on the gauge, the batteries in question may need changing.
- 6.1.2. To replace the batteries, slide back the battery covers on the laser alignment unit to reveal the battery compartments and fit new batteries. Dispose of old batteries correctly (see Battery Removal section on next page). Refit the covers.
- 6.1.3. Periodically clean all the measuring units and tools with a slightly dampened cloth.
- 6.1.4. The lasers should be calibrated on a yearly basis and in particular if the units are damaged and there is doubt that the laser heads are still in alignment. Contact your Sealey dealer to arrange returning the unit for re-calibration.
- 6.1.5 Alternatively, a calibration rig (Model No: GA70CR) is available for purchase if required.



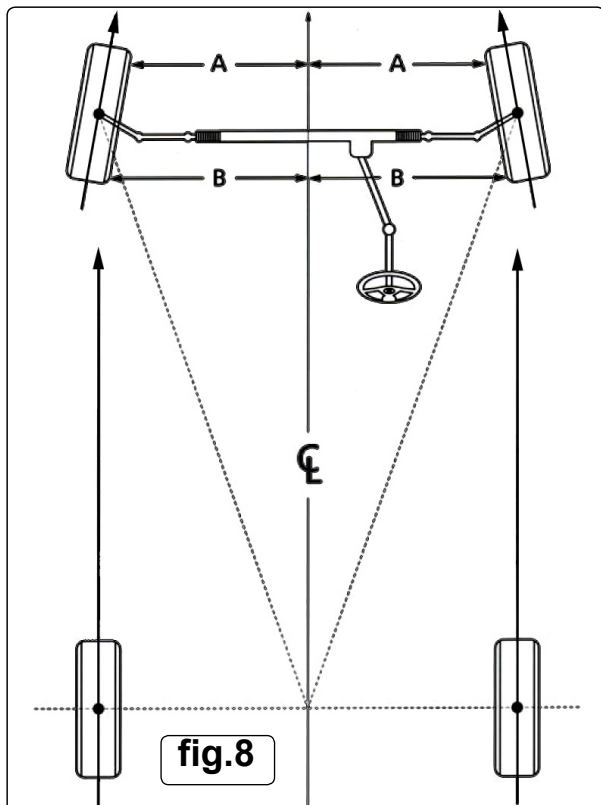

**FRONT WHEEL TRACKING  
(DIAGRAM SHOWS THE FRONT  
WHEELS 'TOED IN')**

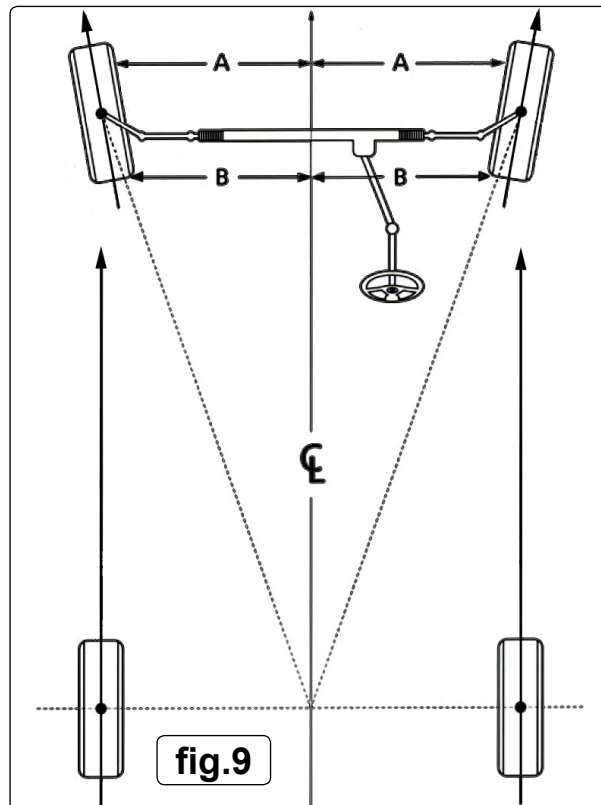

**FRONT WHEEL TRACKING  
(DIAGRAM SHOWS THE FRONT  
WHEELS 'TOED OUT')**

Parts support is available for this product. To obtain a parts listing and/or diagram, please log on to [www.sealey.co.uk](http://www.sealey.co.uk), email [sales@sealey.co.uk](mailto:sales@sealey.co.uk) or phone 01284 757500.

**Environmental Protection.**



Recycle unwanted materials instead of disposing of them as waste. All tools, accessories and packaging should be sorted, taken to a recycle centre and disposed of in a manner which is compatible with the environment.

When the product is no longer required, it must be disposed of in an environmentally protective way. Contact your local solid waste authority for recycling information.



**Battery Removal.**

- 1.Remove the battery covers on each laser alignment unit by unscrewing the cover screws, to reveal the battery compartment.
- 2.Remove the 4 AA batteries from their holder and dispose of the batteries according to local authority guidelines.



Under the Waste Batteries and Accumulators Regulations 2009, Jack Sealey Ltd are required to inform potential purchasers of products containing batteries (as defined within these regulations), that they are registered with Valpak's registered compliance scheme. Jack Sealey Ltd's Batteries Producer Registration Number (BPRN) is BPRN00705

**NOTE:** It is our policy to continually improve products and as such we reserve the right to alter data, specifications and component parts without prior notice.

**IMPORTANT:** No liability is accepted for incorrect use of this product.

**WARRANTY:** Guarantee is 12 months from purchase date, proof of which will be required for any claim.

**INFORMATION:** For a copy of our latest catalogue and promotions call us on 01284 757525 and leave your full name and address, including postcode.



**Sole UK Distributor, Sealey Group,**  
Kempson Way, Suffolk Business  
Park, Bury St. Edmunds, Suffolk,  
IP32 7AR



01284 757500



01284 703534



[www.sealey.co.uk](http://www.sealey.co.uk)



[sales@sealey.co.uk](mailto:sales@sealey.co.uk)