

# INSTRUCTIONS FOR: LASER WHEEL ALIGNMENT GAUGE MODEL No: GA48.V2

Thank you for purchasing a Sealey product. Manufactured to a high standard this product will, if used according to these instructions and properly maintained, give you years of trouble free performance.



**IMPORTANT: PLEASE READ THESE INSTRUCTIONS CAREFULLY. NOTE THE SAFE OPERATIONAL REQUIREMENTS, WARNINGS & CAUTIONS. USE THE PRODUCT CORRECTLY AND WITH CARE FOR THE PURPOSE FOR WHICH IT IS INTENDED. FAILURE TO DO SO MAY CAUSE DAMAGE AND/OR PERSONAL INJURY AND WILL INVALIDATE THE WARRANTY. PLEASE KEEP INSTRUCTIONS SAFE FOR FUTURE USE.**

## 1. SAFETY INSTRUCTIONS

### 1.1 GENERAL SAFETY

- WARNING!** Ensure Health & Safety, local authority, and general workshop practice regulations are adhered to when using this equipment.
- ✓ Maintain the gauge in good condition (use an authorised service agent).
- ✓ Replace or repair damaged parts. Use genuine parts only. Non-authorised parts may be dangerous and will invalidate the warranty.
- ✓ Locate gauge in a suitable working area, keep area clean and tidy and free from unrelated materials.
- WARNING!** Use gauge on level and solid ground.
- ✓ Keep the gauge clean to ensure accurate performance.
- x **DO NOT** use outside in damp or wet weather conditions.
- x **DO NOT** allow untrained persons to operate the gauge.
- x **DO NOT** leave the gauge unattended.
- WARNING!** When setting front end alignment on commercial vehicles never make adjustments to drop arms or interconnecting links. Doing so could result in serious tyre, wheel and steering problems.
- ✓ Any alignment changes deemed necessary as a result of using this equipment must be made strictly in accordance with the vehicle manufacturer's recommendations.

### 1.2 LASER SAFETY

GA48.V2 utilises a Class II laser that emits low levels of visible radiation (i.e. wavelengths between 400 and 700 nanometres) which are safe for the skin but not inherently safe for the eyes. The Class II emission limit is set at the maximum level for which eye protection is normally afforded by natural aversion responses to bright light. Accidental eye exposure is therefore normally safe, although the natural aversion response can be overridden by deliberately staring into the beam, and can also be influenced by the use of alcohol or drugs.

- WARNING!** Do not look or stare into the laser beam as permanent eye damage could result.
- x **DO NOT** direct the laser beam at any person's (or animal's) eyes as eye damage could result. If the beam is obstructed by a person during use, release the contact switch immediately.
- x **DO NOT** use the equipment while under the influence of alcohol, drugs or whilst on medication.
- ✓ Be aware that reflections of the laser beam from mirrors or other shiny surfaces can be as hazardous as direct eye exposure.



## 2. INTRODUCTION & SPECIFICATION

Steel construction gauge measures toe-in and toe-out by contact with wheel rims and laser beam alignment. Works on practically all cars and light commercial vehicles with rim diameters between 200 and 600mm. Some assembly required prior to use. Operating instructions included. Powered by two AA batteries (supplied).

**Wheel rim capacities:** ..... 8" - 24" rim diameter  
**Laser beam height:** ..... Under 50mm  
**Battery:** ..... 2 x type AA 1.4 volts  
**Switch:** ..... Momentary operator pressure  
 ..... (Power off when not depressed)

**Measuring range:** ..... +/- 2deg  
**Laser:** ..... Class II, 1.0 milliwatt, Wavelength 620 - 680nm  
**Estimated battery life:** ..... 6 - 12 months, dependant on use

## 3. ASSEMBLY & CALIBRATION

- WARNING!** Do not switch on the laser unit when detached from the main gauge. When correctly assembled to the gauge the laser should only be switched on when the two sides of the gauge are correctly positioned in relation to each other either for calibration purposes or for wheel alignment use.
- 3.1 ASSEMBLY - fig 1**
  - 3.1.1 Slide the four arms onto the main bars, two arms onto each bar, two of the arms have two thumb screws, these must go on first and are labelled 'M' - mirror and 'L' - Laser and so should be put on the correct bars.
  - 3.1.2 Tighten the thumb screws into position.
  - 3.1.3 Use the thumb screws on the base to adjust the level, using the built in spirit level as guidance.
  - 3.1.4 Remove the battery end cap screw then cap (fig.1) to reveal the battery compartment. Remove the small screw securing the top of the compartment and insert two AA batteries.
- 3.2 CALIBRATION.** The gauge will be calibrated each time it is used as part of the process of checking wheel alignment. Calibration will be done with the two halves of the gauge facing each other with the contact bars touching. For further details refer to the operating instructions which follow.

fig.1

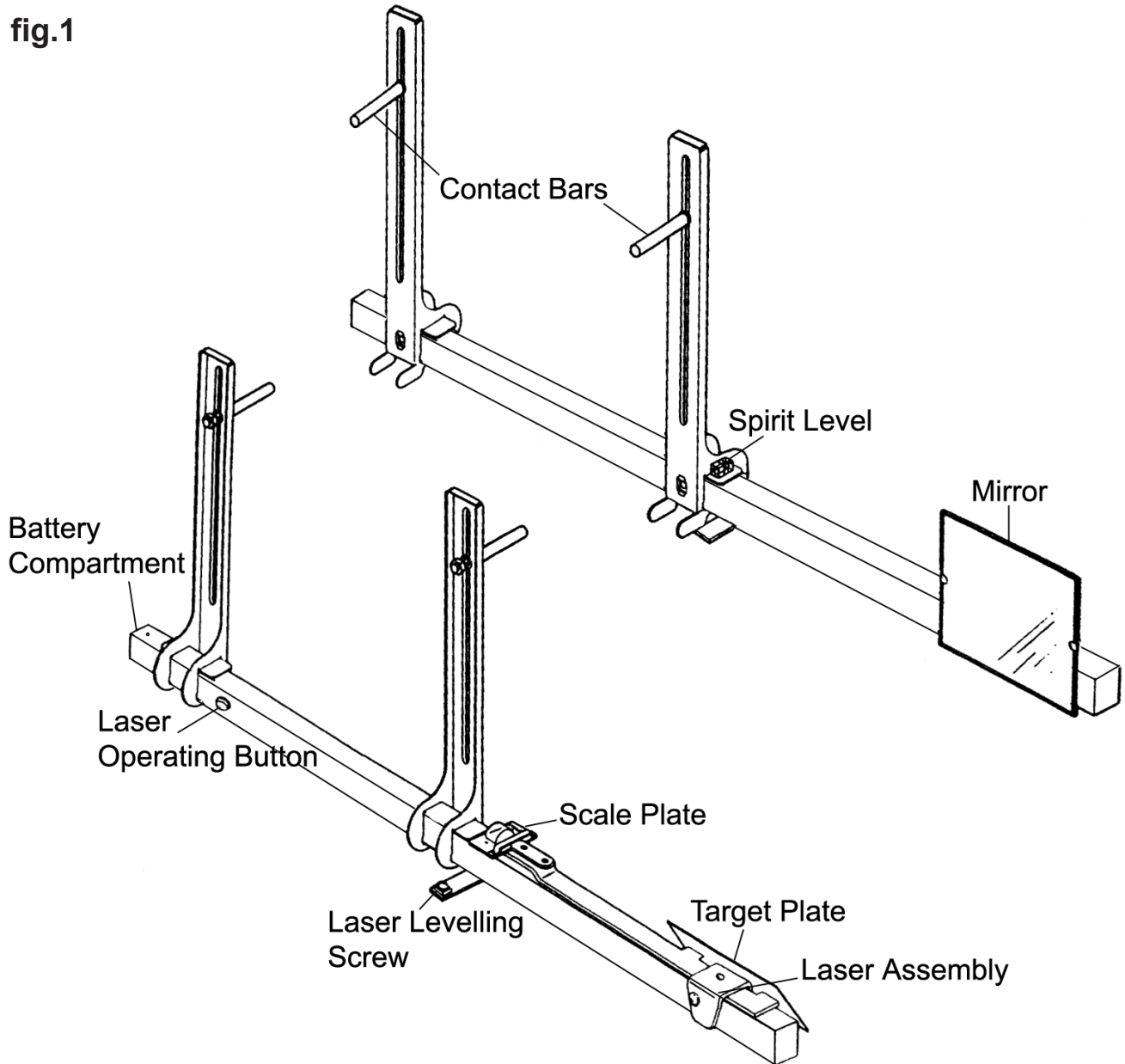

#### 4. OPERATING - CARS AND VANS

##### 4.1 OPERATION

□ Prior to use, check vehicle manufacturer's recommendations relating to loading. Check that tyre pressures are correct.

4.1.1 Ensure that the vehicle is on a smooth level surface with the wheels pointing straight ahead, **DO NOT** back the vehicle into position.

4.2 Position the laser unit against the offside front wheel (see fig.2) and adjust the height of the contact bars closest to a horizontal line through the centre of the wheel. At the same time adjust the side to side positioning of the contact bars so that they touch the sidewall of the tyre either side of the rim. Position the tips of the contact bars to touch the centre of the sidewalls at the greatest point of curvature. Avoid any ribs or raised lettering on the tyre side wall.

4.1.3 The contact bars of the mirror unit should now be set up to the same height and width as the laser unit. To do this remove the laser unit from its position on the tyre and place it in front of the mirror unit to make the necessary adjustments.

4.1.4 When the contact bar arrangements on both units match, proceed to calibrate the gauge. (See calibration set-up in figure 3).

4.1.5 Stand both units close together so that the tips of the contact bars are touching. The mirror unit (fig.3.B) should be vertical, check the built-in spirit level (fig.1) and adjust using the thumb screw on the arm (fig.1). If the laser beam is not visible on the target plate loosen the thumb screw on the arm (fig.1) and tilt the laser unit until the beam is visible on the target plate (fig.1).

4.1.6 Move the pointer arm (fig.3.C) until the laser beam is visible on the vertical centre line in between the two bold arrows.

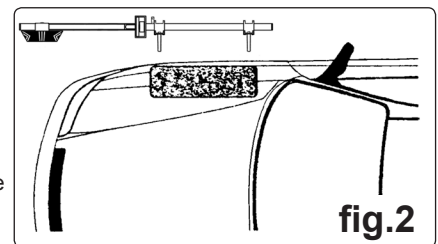

fig.2

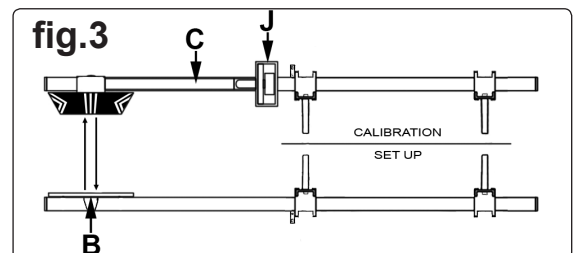
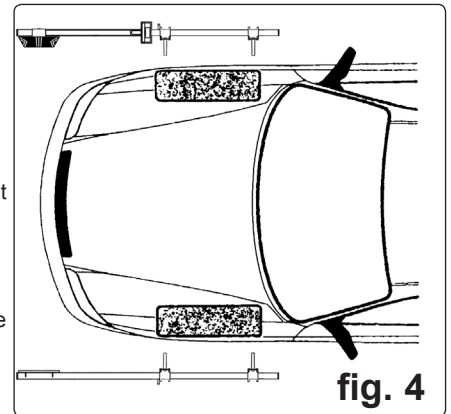

fig.3

- 4.1.7 The lens attached to the end of the pointer arm should now be positioned over the zero mark on the graduated scale plate (fig.1 or fig.3.J). If it is not, slacken the two wing nuts and adjust the scale plate zero mark to coincide with the indicator line on the lens. Retighten the wing nuts. The gauge is now ready for use in this particular situation. Should you proceed to use the gauge on a different vehicle requiring you to alter the contact bar settings you will need to re-calibrate the gauge as just described.
- 4.1.8 Now set up the two parts of the gauge (see fig.4) and hold down the laser button (the beam will cut-out when the button is released). Take hold of the adjusting arm and move it until the laser beam is on the centre line of the target plate. The graduated scale will now show the amount of toe-in or toe-out in degrees and minutes. Each division of the scale represents 10 minutes. If you cannot see the laser on the target plate then you will need to adjust the laser unit using the thumbscrews.
- 4.1.9 To allow for possible lateral run out of wheels and tyres, move the vehicle forward until the wheels have rotated half a revolution (180°) and repeat the operation. If you obtain a different reading, average the two results.

**Note:** Any alignment changes necessary must be made strictly in accordance with the vehicle manufacturer's recommendations.



## 6. MAINTENANCE

- 6.1 If laser beam becomes difficult to see on target replace 2 X AA batteries.
- 6.1.1 Remove the battery end cap screw then cap (fig.1) to reveal the battery compartment.
- 6.1.2 Remove the small screw securing the top of the compartment and remove the exhausted batteries then insert two new AA batteries.
- 6.1.3 Replace cover and securing screw. Then the end cap and screw.
- 6.2 Periodically clean the unit with a damp cloth, for best performance keep the mirror unit free from grease, oil and dirt.

### Environmental Protection.



Recycle unwanted materials instead of disposing of them as waste. All tools, accessories and packaging should be sorted, taken to a recycle centre and disposed of in a manner which is compatible with the environment.



When the product is no longer required, it must be disposed of in an environmentally protective way.



### Battery Removal

- 1.Remove the battery end cap screw then the cap (fig.1A) to reveal the battery compartment.
- 2.Remove the small screw securing the top of the compartment and dispose of batteries according to local authority guidelines.

**Declaration of Conformity** We, the sole importer into the UK, declare that the product listed here is in conformity with the following standards and directives.

#### LASER WHEEL ALIGNMENT GAUGE MODEL No: GA48.V2

EN 60825 -1 Laser safety  
93/6 2002/95/EC RoHS Directive  
2002/96/EC WEEE Directive  
8/EEC CE Marking Directive

The construction file for this product is held by the Manufacturer and may be inspected, by a national authority, upon request to Jack Sealey Ltd.



Signed by Tim Thompson

4th August 2009

For Jack Sealey Ltd. Sole importer into the UK of Sealey Professional Tools.

**NOTE:** It is our policy to continually improve products and as such we reserve the right to alter data, specifications and component parts without prior notice.

**IMPORTANT:** No liability is accepted for incorrect use of this product.

**WARRANTY:** Guarantee is 12 months from purchase date, proof of which will be required for any claim.

**INFORMATION:** Call us for a copy of our latest catalogue on 01284 757525 and leave your full name and address including your postcode.



Sole UK Distributor  
Sealey Group,  
Bury St. Edmunds, Suffolk.



01284 757500



01284 703534



[www.sealey.co.uk](http://www.sealey.co.uk)



[sales@sealey.co.uk](mailto:sales@sealey.co.uk)