

INSTRUCTIONS for: CAMBER, CASTOR & KING PIN GAUGE SET MODEL No: GA42.V2

Thank you for purchasing a Sealey product. Manufactured to a high standard this product will, if used according to these instructions and properly maintained, give you years of trouble free performance.



IMPORTANT: PLEASE READ THESE INSTRUCTIONS CAREFULLY. NOTE THE SAFE OPERATIONAL REQUIREMENTS, WARNINGS & CAUTIONS. USE THE PRODUCT CORRECTLY AND WITH CARE FOR THE PURPOSE FOR WHICH IT IS INTENDED. FAILURE TO DO SO MAY CAUSE DAMAGE OR PERSONAL INJURY, AND WILL INVALIDATE THE WARRANTY. PLEASE KEEP INSTRUCTIONS SAFE FOR FUTURE USE.

1. SAFETY INSTRUCTIONS

- ❑ **WARNING!** Ensure Health & Safety, local authority, and general workshop practice regulations are adhered to when using this equipment.
- ✓ Maintain the set in good condition (use an authorised service agent).
- ✓ Replace or repair damaged parts. Use genuine parts only. Non-authorised parts may be dangerous and will invalidate the warranty.
- ❑ **WARNING!** Use this set on vehicles that are parked on level and solid ground.
- ✓ Locate vehicle in a suitable working area, keep area clean and tidy and free from unrelated materials.
- x **DO NOT** use outside in damp or wet weather conditions.
- x **DO NOT** allow untrained persons to use this set.
- ✓ Keep the set clean to ensure accurate performance.
- ❑ **WARNING!** When setting front end alignment on commercial vehicles, never make adjustments to drop arms or interconnecting links. Doing so could result in serious tyre, wheel and steering problems.
- ✓ **NOTE: Any alignment changes deemed necessary as a result of using this equipment must be made strictly in accordance with the vehicle manufacturer's recommendations.**
- ❑ **WARNING!** The warnings, cautions and instructions contained within this document cannot cover all possible conditions and situations that may occur. It must be understood that common sense and caution are factors which cannot be built into this product, but must be applied by the operator.



fig.1

2. INTRODUCTION & SPECIFICATION

This set consists of two separate instruments. The long handled assembly is used to measure camber angles and check floor level. The smaller assembly checks castor angles and king pin inclination in one operation and can be attached to a stub axle nut, to a wheel stud or to a centre lock wheel. It is recommended that these instruments are used in conjunction with our GA44 steering turntables for greater accuracy.

3. CONTENTS

Carefully unpack the contents of the box. If any parts are missing or damaged, contact your Sealey dealer immediately.

Contents:

1. Camber Angle Gauge.
2. Stud Axle Clamp.
3. Castor and King Pin Gauge.
4. Wheel Stud Mounting Bracket - Large (for use with item 3).
5. Wheel Stud Mounting Bracket - Small (for use with item 3).
6. Hooks for Centre Lock Clamp.
7. Large Conical Washer (for use with item 4).
8. Centre Lock Clamp.
9. Small Conical Washer (for use with item 5).
10. Pin (for tightening item 2).

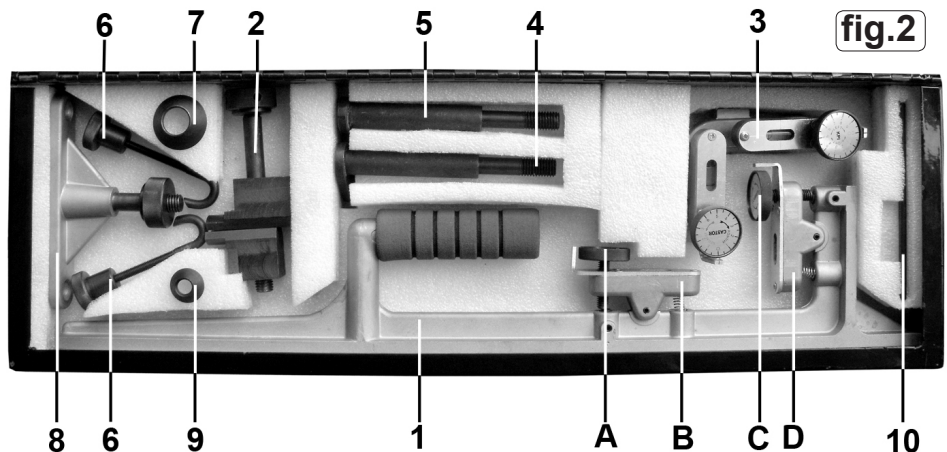

fig.2

4. MEASURING CAMBER ANGLE

- 4.1. Check that the floor is level as described in Section 6, and that the tyre pressures are correct.
- 4.2. To set the gauge up, hold it in the vertical position and adjust the 'camber' dial (fig.2.C) so that '0' is in line with the index mark.
- 4.3. Apply the long edge of the gauge to the tyre side wall holding it in a vertical position (fig.1). To obtain an accurate reading, avoid the part of the tyre wall that bulges near ground level.
- 4.4. Turn the camber dial (fig.2.C) in either direction until the bubble in the spirit level (fig.2.D) is centred. The number of graduations turned through, represents the camber 'in' or camber 'out' in degrees depending on which direction it was necessary to turn the dial.
NOTE : If the dial is rotated more than half a revolution (3 graduations) and the spirit level bubble has not centred, continue to turn the dial until the bubble has centred and make a note of the graduations needed (i.e. they will not be correctly numbered after 3 graduations).
- 4.5. If it has been established that the floor is not level, make any necessary adjustments to the readings (See Section 6 chart).
- 4.6. Any changes deemed necessary as a result of using this set, must be made strictly in accordance with the vehicle manufacturer's recommendations.

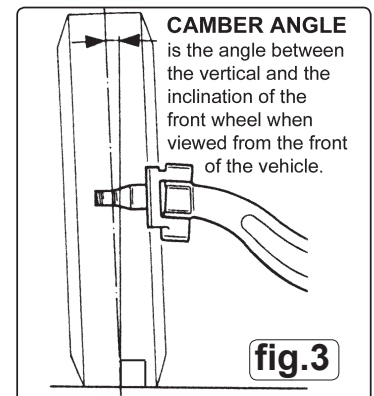

fig.3

5. MEASURING CASTOR ANGLE & K.P.I.

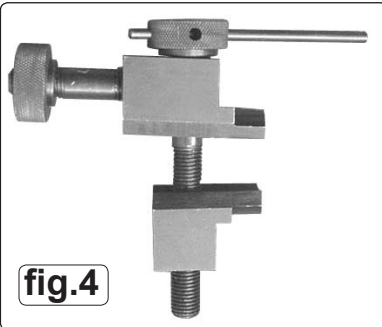

fig.4

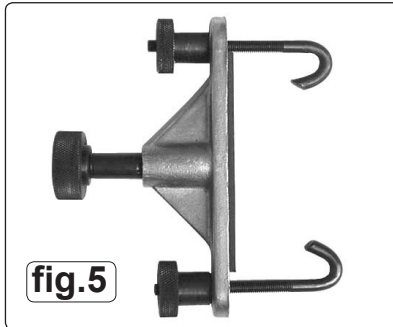

fig.5



fig.6

- 5.1. It is recommended that this gauge is used in conjunction with a pair of GA44 steering turntables, to improve accuracy. The vehicle's front wheels should be positioned centrally on the turntables as described in the instructions for the GA44. Front wheel drive vehicles should have the foot brake applied by means of a brake pedal depressor or similar means, to prevent the front wheels rotating, whilst using the gauge. Before taking any readings, the locking pins should be removed from the turntables.
- 5.2. There are three alternative ways of mounting the castor angle and king pin inclination gauge to a wheel. The most common method is to use one of the wheel stud brackets as shown in fig.6. Each wheel stud bracket is provided with a matching conical washer which may be needed to accommodate reduced diameter studs. The centre lock bracket shown in fig.5 is for use with centre lock wheels where the two hooks can either be attached to the spokes on the wheel or hooked around the back of the centre lock nut. The stud axle clamp shown in fig.4 allows the gauge to be attached to a central hub nut. When the appropriate clamp is in position, slide the gauge onto the spindle and secure it with the knurled nut, positioning the gauge in an approximate horizontal position. The gauge should be positioned as shown in fig.6.
- 5.3. Check that the floor is level as described in Section 6, and that the tyre pressures are correct.
- 5.4. Turn the front of the wheel to be checked, IN by 20° (i.e. the off-side wheel turned to the left or the near-side wheel turned to the right.) Turn both dials on the gauge until zero is in line with the index pointer then centre the bubbles on both spirit levels by turning the knurled screws below each dial.
- 5.5. Next turn the front of the wheel being checked, OUT by 20° (opposite to above step).
- 5.6. Centre the bubbles in both spirit levels by turning the CASTOR dial and KPI dial respectively making a note of the number of graduations through which each dial rotates.
- 5.7. The scales on both dials are additive. If the king pin inclination dial is rotated a full revolution and the spirit level bubble is still not centred continue to turn the dial until it is centred. The king pin inclination angle is therefore the sum of the total number of graduations that the dial has been turned through. The same applies to the castor angle dial readings.
- 5.8. If the floor is not level, make any necessary adjustments to the readings (See Section 6 chart).
- 5.9. Any changes deemed necessary as a result of using this set, must be made strictly in accordance with the vehicle manufacturer's recommendations.

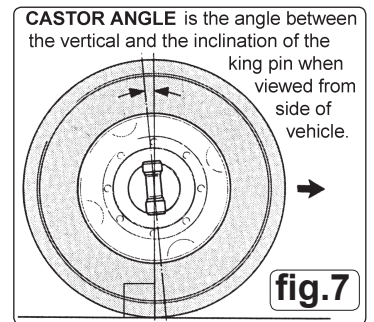

fig.7

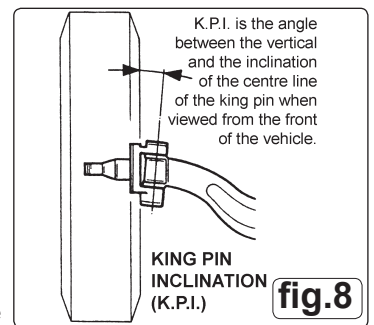

fig.8

6. CHECKING FOR LEVEL FLOOR

- 6.1. Check that the floor is level using the camber angle gauge as follows. Turn the dial marked degrees (see fig.2.A) so that '0' is in line with the index pointer. Place the gauge on the floor at right angles to the wheel to be checked (place parallel to the wheel when measuring castor angle). If the bubble in the spirit level is not centred, then the floor is not level. Turn the dial in the required direction until the bubble is centred. The slope of the floor in degrees is represented by the number of graduations turned on the dial.
- 6.2. Adjusting readings when the floor is sloping. Readings can still be taken on a sloping surface up to a maximum of 3°. Establish the angle of the slope using the camber gauge as described above. Note the direction of the slope and the vehicles orientation on it. To make a correction, the slope angle should either be added to, or subtracted from the reading according to the chart below. Where the chart indicates N/A this means that no adjustment is necessary in that particular orientation.

SLOPING FLOOR COMPENSATION CHART	SLOPING SIDE TO SIDE				SLOPING LENGTH WISE			
	NEARSIDE (HIGH)	OFFSIDE	NEARSIDE	OFFSIDE (HIGH)	REAR	FRONT (HIGH)	REAR (HIGH)	FRONT
SLOPE ANGLE ORIENTATION								
CAMBER ANGLE	ADD X°	SUBTRACT X°	SUBTRACT X°	ADD X°	N/A	N/A	N/A	N/A
KING PIN INCLINATION	SUBTRACT X°	ADD X°	ADD X°	SUBTRACT X°	N/A	N/A	N/A	N/A
CASTOR ANGLE	N/A	N/A	N/A	N/A	Subtract Y° from + readings Add Y° to - readings		Add Y° to + readings Subtract Y° from - readings	

NOTE: It is our policy to continually improve products and as such we reserve the right to alter data, specifications and component parts without prior notice.

IMPORTANT: No liability is accepted for incorrect use of this product.

WARRANTY: Guarantee is 12 months from purchase date, proof of which will be required for any claim.

INFORMATION: For a copy of our latest catalogue and promotions call us on 01284 757525 and leave your full name and address, including postcode.



Sole UK Distributor, Sealey Group,
Kempson Way, Suffolk Business Park,
Bury St. Edmunds, Suffolk,
IP32 7AR

01284 757500

01284 703534

www.sealey.co.uk

sales@sealey.co.uk