



ENGINE STAND 350KG

MODEL NO: **ES350.V2**

Thank you for purchasing a Sealey product. Manufactured to a high standard, this product will, if used according to these instructions, and properly maintained, give you years of trouble free performance.

IMPORTANT: PLEASE READ THESE INSTRUCTIONS CAREFULLY. NOTE THE SAFE OPERATIONAL REQUIREMENTS, WARNINGS & CAUTIONS. USE THE PRODUCT CORRECTLY AND WITH CARE FOR THE PURPOSE FOR WHICH IT IS INTENDED. FAILURE TO DO SO MAY CAUSE DAMAGE AND/OR PERSONAL INJURY AND WILL INVALIDATE THE WARRANTY. KEEP THESE INSTRUCTIONS SAFE FOR FUTURE USE.



Refer to instructions



Wear protective gloves



Wear safety footwear



Wear protective clothing

1. SAFETY

- ❑ **WARNING!** Ensure all Health and Safety, local authority, and general workshop practice regulations are strictly adhered to when using this equipment.
- ✘ **DO NOT** use unit if damaged.
- ✓ Replace or repair damaged parts. Use recommended parts only. Unauthorised parts may be dangerous and will invalidate the warranty.
- ✓ Keep the stand clean for best and safest performance.
- ✓ Locate the stand in a suitable work area. Keep area clean and tidy and free from unrelated materials. Ensure there is adequate lighting.
- ✓ Use on a firm, level surface capable of sustaining the stand and the load.
- ✓ Maintain correct balance and footing. Ensure the floor is not slippery and wear non-slip shoes.
- ✓ Ensure all non-essential persons keep a safe distance whilst the stand is in use.
- ✓ Lock mounting plate in position with locking pin before fixing a load and ensure the load is centred and securely mounted on the mounting plate.
- ✓ When an engine is mounted, take the weight of the engine on the handle **before** removing the locking pin.
- ✓ Ensure the stand and load are stable.
- ✓ To move a loaded stand, steady the load and push from behind the main post of the stand so that the castor wheel is ahead of the load.
- ✘ **DO NOT** pull the unit backwards, or push from the side, as this may cause the stand to tip.
- ✓ Ensure surface over which the stand is to travel is strong enough to take the stand and load and that it is not cracked, uneven or obstructed.
- ✘ **DO NOT** allow untrained persons to use the stand.
- ✘ **DO NOT** exceed the rated capacity of 350kg.
- ▲ **DANGER! DO NOT** work **under** an engine mounted on the stand.
- ✘ **DO NOT** use the stand for purposes other than those for which it is designed.
- ✓ When not in use store stand in a safe, dry, childproof area.

2. INTRODUCTION

Accepts a wide variety of engines and transmissions. The heads swivel 360° for accessibility to all parts of the engine. Fully adjustable mounting arms. Swivel castors provide excellent manoeuvrability. Maximum Load Length: 700mm.

3. SPECIFICATION

Model No: ES350
Capacity: 350kg
Nett Weight: 16.9kg
Size (W x D x H): 890 x 790 x 920mm
Maximum Load Length: 700mm

4. ASSEMBLY

- 4.1. Referring to fig.1, slide a wheel (20) onto each axle stub at either end of the axle leg (3). Place an M16 axle washer (21) over each stub and retain each wheel by pushing a R spring clip (22) through the hole in the end of each axle stub.
- 4.2. Referring to fig.2, bolt the castor (15) to the mounting plate at the end of the front leg (2) using four M8 bolts (16), four M8 flat washers (18), four spring washers (19) and four M8 nuts (17).
- 4.3. Referring to fig.3, attach the four engine mounting arms (10) to the mounting plate (8) using four M14 bolts (11), four M14 flat washers (13), four spring washers (12) and four M14 nuts (14).
- 4.4. Assemble the main frame referring to fig.4. Slide the front leg (2) into the square tube at the base of the main post (1) ensuring that the castor is facing downwards and the hole at the other end of the leg is aligned with the hole in the bottom of the square tube. Insert the 70mm M8 bolt (4) entirely through the axle leg (3) then bring the leg up underneath the main post so that the protruding bolt appears inside the square tube. Fix the three main components together using the M10 washer (5), M10 spring washer (7) and the M10 nut (6) and tighten firmly.
- 4.5. Take the engine mounting plate assembly and insert the tubular section through the tube at the top of the main post. Rotate the assembly so that one of the six holes in the inner tube aligns with the single hole in the top of the post. Insert the locking pin (9).
- 4.6. Insert the handle through the holes in the rear end of the engine mounting plate tube.

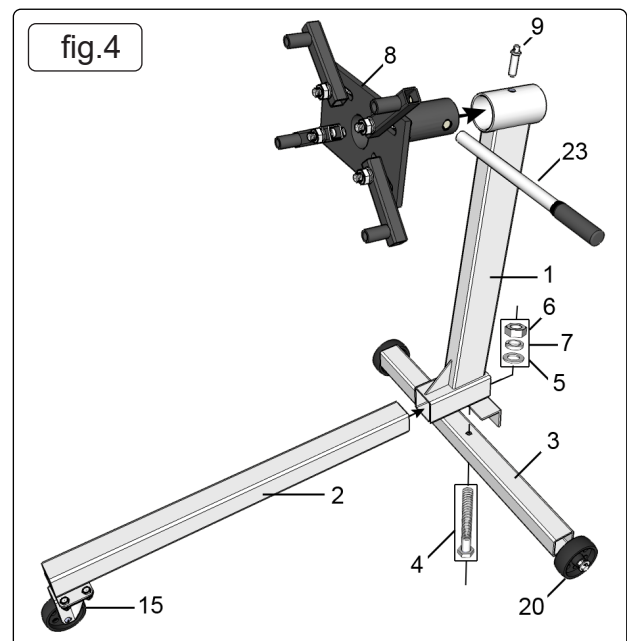
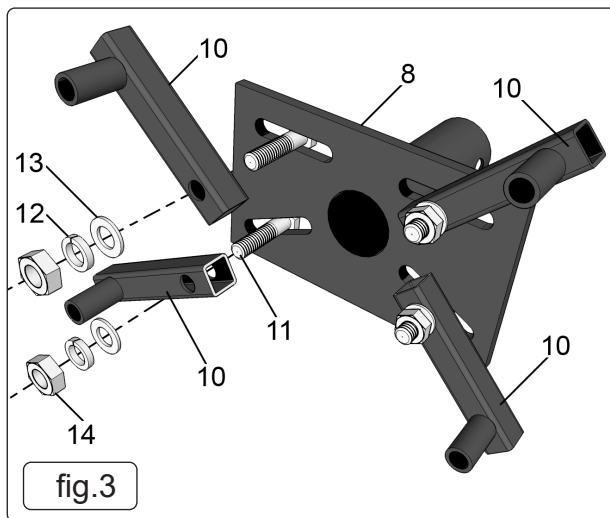
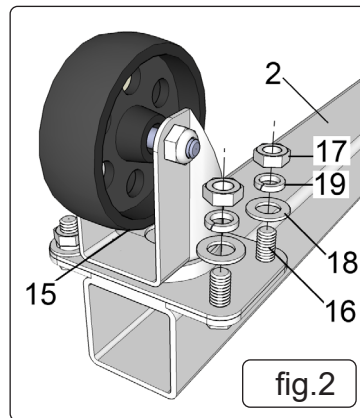
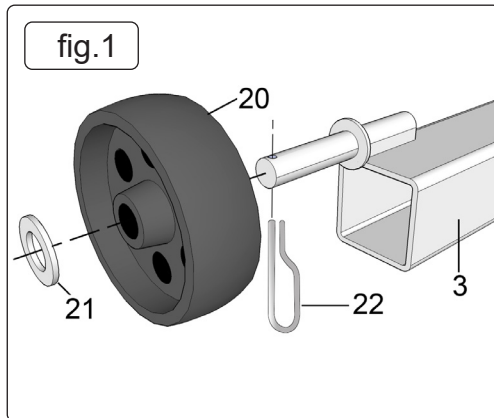

ENVIRONMENT PROTECTION

Recycle unwanted materials instead of disposing of them as waste. All tools, accessories and packaging should be sorted, taken to a recycling centre and disposed of in a manner which is compatible with the environment. When the product becomes completely unserviceable and requires disposal, drain any fluids (if applicable) into approved containers and dispose of the product and fluids according to local regulations.

Note: It is our policy to continually improve products and as such we reserve the right to alter data, specifications and component parts without prior notice. Please note that other versions of this product are available. If you require documentation for alternative versions, please email or call our technical team on technical@sealey.co.uk or 01284 757505.

Important: No Liability is accepted for incorrect use of this product.

Warranty: Guarantee is 12 months from purchase date, proof of which is required for any claim.

Sealey Group, Kempson Way, Suffolk Business Park, Bury St Edmunds, Suffolk. IP32 7AR

01284 757500

01284 703534

sales@sealey.co.uk

www.sealey.co.uk