

Thank you for purchasing a Sealey Product. Manufactured to a high standard this product will, if used according to these instructions and properly maintained, give you years of trouble free performance.

⚠ IMPORTANT: PLEASE READ THESE INSTRUCTIONS CAREFULLY. NOTE THE SAFE OPERATIONAL REQUIREMENTS, WARNINGS AND CAUTIONS. USE THIS PRODUCT CORRECTLY AND WITH CARE FOR THE PURPOSE FOR WHICH IT IS INTENDED. FAILURE TO DO SO MAY CAUSE DAMAGE AND/OR PERSONAL INJURY, AND WILL INVALIDATE THE WARRANTY. PLEASE KEEP INSTRUCTIONS SAFE FOR FUTURE USE.

1. SAFETY INSTRUCTIONS

- ✓ Ensure that the engine support is in good working order. Take action for immediate repair or replacement of damaged parts. *Use genuine parts only. The use of unauthorised parts may be dangerous and will invalidate the warranty.*
- ✓ Locate the vehicle in a suitable, well lit work area.
- ✓ Keep work area clean and tidy and free from unrelated materials.
- ✓ Ensure the vehicle handbrake is engaged and the engine/motor is switched off.
- ✓ Ensure all non-essential persons keep a safe distance whilst the engine support is in use.
- x **DO NOT** use the engine support if damaged.
- x **DO NOT** allow untrained persons to operate the engine support.
- x **DO NOT** use the engine support for purposes other than that for which it is designed.
- x **DO NOT** exceed the rated capacity of the engine support.

2. INTRODUCTION & SPECIFICATION

2.1. The ES300 engine support is designed to support and accurately position engines during maintenance operations such as replacing anti-vibration mountings and certain body panels. Also used as an aid for the removal of gearboxes and transmissions. Beam is supported on 4 rubber feet and fine-lift control obtained by using a screw mechanism. Supplied with a short length of chain.

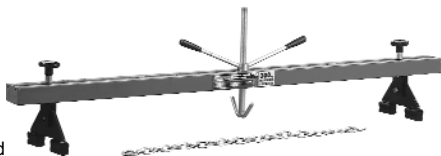

| | | | |
|---------------------------------|---------|-------------------------|--------|
| 2.2. Maximum Capacity | .300kg | Minimum Width | .660mm |
| Maximum Width | .1420mm | Screw Travel | .210mm |

3. ASSEMBLY INSTRUCTIONS

Note: Numbers in brackets refer to item numbers shown in the parts diagram.

- 3.1. Slot the threaded section of the standing block (8) up through the outer slotted section of the beam. Fit a washer (7) and secure using grip, pin and spring pin (5, 6 & 4). Do not tighten.
- 3.2. Remove the bolt (9) from the standing block (8) fit standing block (10) and refit and tighten the bolt.
- 3.3. Repeat paragraphs 3.1 and 3.2 at the other outer section of the beam (14).
- 3.4. Slot the threaded section of the adjustable screw (12) up through the centre slotted section of the beam (14), fit the washer (3) and secure using the operating clamp assembly (2).
- 3.5. The engine support is now ready for use.

Note: Ensure both grips (5) and all nuts are tightened before applying a load.

4. OPERATING INSTRUCTIONS

Note: Numbers in brackets refer to item numbers shown in the parts diagram.

- 4.1. Ensure the adjustable screw (12) is wound to its highest position to prevent damage whilst locating the engine support over an engine bay.
- 4.1. Ensure the grips (5) are loose and locate the rubber blocks (11) in the gutters of the vehicle's front wing panels or close to the suspension strut towers.
- 4.2. Attach the ends of the chain to the lifting brackets on the engine. Note: Refer to manufacturer's handbook to identify lifting brackets.
- 4.3. Lower the adjustable screw and hook the chain around the hook as shown in fig.1.
- 4.4. Tighten both grips (5) and all nuts.
- 4.5. Rotate the operating clamp assembly to tighten the chain and support the engine.

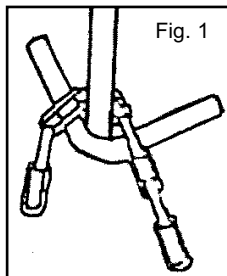

4.6. On completion of the maintenance task, rotate the operating clamp assembly to release the tension on the chain.

4.7. Unhook the chain, loosen both grips (5) and remove the engine support from the vehicle.

4.8. Remove the chain from the engine lifting points.

5. PARTS

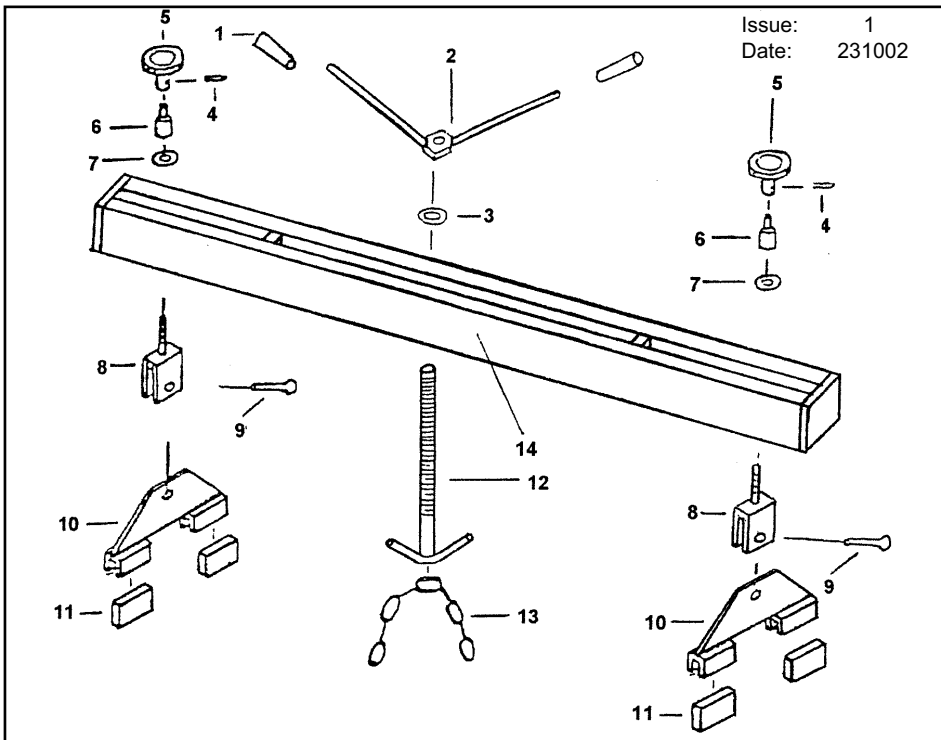

| Item | Part No | Description | Item | Part No | Description |
|------|-----------|--------------------------|------|-----------|------------------|
| 1 | ES300C-01 | Grip, handle bar | 8 | ES300C-08 | Standing block |
| 2 | ES300C-02 | Operating clamp assembly | 9 | ES300C-09 | Screw |
| 3 | ES300C-03 | Washer | 10 | ES300C-10 | Standing block |
| 4 | ES300C-04 | Spring pin | 11 | ES300C-11 | Rubber block |
| 5 | ES300C-05 | Grip | 12 | ES300C-12 | Adjustable screw |
| 6 | ES300C-06 | Pin | 13 | ES300C-13 | Chain |
| 7 | ES300C-07 | Washer | 14 | ES300C-14 | Beam |

NOTE: It is our policy to continually improve products and as such we reserve the right to alter data, specifications and component parts without prior notice.

IMPORTANT: No liability is accepted for incorrect use of this equipment.

WARRANTY: Guarantee is 12 months from purchase date, proof of which will be required for any claim.

INFORMATION: For a copy of our latest catalogue and promotions, call us on 01284 757525 and leave your full name and address including your postcode.



Sole UK Distributor
Sealey Group, Bury St. Edmunds, Suffolk.

01284 757500



01284 703534

E-mail: sales@sealey.co.uk
Web: www.sealey.co.uk