

Thank you for purchasing a Sealey product. Manufactured to a high standard this product will, if used according to these instructions and properly maintained, give you years of trouble free performance.

⚠ IMPORTANT: PLEASE READ THESE INSTRUCTIONS CAREFULLY. NOTE THE SAFE OPERATIONAL REQUIREMENTS, WARNINGS AND CAUTIONS. USE THE PRODUCT CORRECTLY AND WITH CARE FOR THE PURPOSE FOR WHICH IT IS INTENDED. FAILURE TO DO SO MAY CAUSE DAMAGE OR PERSONAL INJURY AND WILL INVALIDATE THE WARRANTY. PLEASE KEEP INSTRUCTIONS SAFE FOR FUTURE USE.

The use of symbols in this document is to attract your attention to possible danger. The symbols and warnings themselves do not eliminate any danger, nor are they substitutes for proper accident prevention measures.

1. SAFETY INSTRUCTIONS

1.1. ELECTRICAL SAFETY. **WARNING! It is the user's responsibility to read, understand and comply with the following:**

You must check all electrical equipment and appliances to ensure they are safe before using. You must inspect power supply leads, plugs and all electrical connections for wear and damage. You must ensure the risk of electric shock is minimised by the installation of appropriate safety devices. An RCCB (Residual Current Circuit Breaker) should be incorporated in the main distribution board. We also recommend that an RCD (Residual Current Device) is used with all electrical products. It is particularly important to use an RCD with portable products that are plugged into an electrical supply not protected by an RCCB. If in doubt consult a professional electrician. You may obtain a Residual Current Device by contacting your Sealey dealer. **You must** also read and understand the following instructions concerning electrical safety.

- 1.1.1. The **Electricity At Work Act 1989** requires all portable electrical appliances, if used on business premises, to be tested by a qualified electrician, using a Portable Appliance Tester (PAT), at least once a year.
- 1.1.2. The **Health & Safety at Work Act 1974** makes owners of electrical appliances responsible for the safe condition of the appliance, and the safety of the appliance operator. **If in any doubt about electrical safety, contact a qualified electrician.**
- 1.1.3. Ensure the insulation on all cables and the product itself is safe before connecting to the mains power supply. See 1.1.1. & 1.1.2. above and use a Portable Appliance Tester (PAT).
- 1.1.4. Ensure that cables are always protected against short circuit and overload.
- 1.1.5. Regularly inspect power supply, leads, plugs for wear and damage and check power connections to ensure that none is loose.
- 1.1.6. **Important:** Ensure the voltage marked on the product is the same as the electrical power supply to be used and check that plugs are fitted with the correct capacity fuse. A 13 amp plug may require a fuse smaller than 13 amps for certain products (*subject to 1.1.10. below*). See fuse rating at right.
- 1.1.7. DO NOT pull or carry the appliance by its power supply lead. Products such as welders must not be pulled or carried by their output cables.
- 1.1.8. DO NOT pull plugs from sockets by the cable.
- 1.1.9. DO NOT use worn or damaged leads, plugs or connections. Immediately replace or have repaired by a qualified electrician. A U.K. 3 pin plug with ASTA/BS approval is fitted. In case of damage, cut off and fit a new plug according to the following instructions (discard old plug safely).

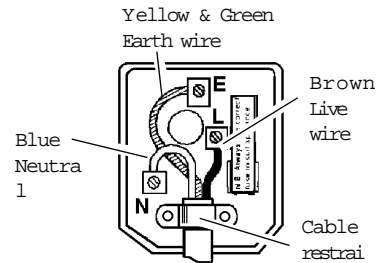

FUSE RATING
THIS PRODUCT MUST BE FITTED
WITH A
13 Amp FUSE

(UK only - see diagram at right). **Ensure the unit is correctly earthed via a three-pin plug.**

a) Connect the GREEN/YELLOW earth wire to the earth terminal 'E'.

b) Connect the BROWN live wire to live terminal 'L'.

c) Connect the BLUE neutral wire to the neutral terminal 'N'.

After wiring, check there are no bare wires, that all wires have been correctly connected, that the cable outer insulation extends beyond the restraint and that the cable restraint is tight.

Double insulated products are often fitted with live (BROWN) and neutral (BLUE) wires only. Double insulated products are always marked with this symbol . **To re-wire, connect the brown & blue wires as indicated above. DO NOT connect the brown or blue to the earth terminal.**

- 1.1.10. Some products require more than a 13 amp electrical supply. In such a case, **NO** plug will be fitted. **You must** contact a qualified electrician to ensure a 30 amp fused supply is available. We recommend you discuss the installation of an industrial round pin plug and socket with your electrician.
- 1.1.11. **Cable extension reels.** When a cable extension reel is used it should be fully unwound before connection. A cable reel with an RCD fitted is recommended since any product which is plugged into the cable reel will be protected. The section of the cable on the reel is important. We suggest at least 1.5mm² section cores but to be absolutely sure that the capacity of the cable reel is suitable for this product and for others that may be used in the other output sockets, we recommend the use of 2.5mm² section.

1.2 GENERAL SAFETY

WARNING! Ensure Health & Safety, local authority, and general workshop practice regulations are adhered to when using this equipment.

Familiarise yourself with the product's application and limitations, as well as the specific potential hazards peculiar to the extractor.

WARNING! Disconnect the unit from the mains power before servicing or performing any maintenance.

Maintain the extractor in good condition (use an authorised service agent).

Replace or repair damaged parts. *Use genuine parts only. Non-authorised parts may be dangerous and will invalidate the warranty.*

Locate the extractor in a suitable working area, keep area clean and tidy and free from unrelated materials. Ensure there is adequate lighting.

WARNING! Use only on level ground or slopes not exceeding 8%.

Ensure there are no flammable or combustible materials near the work area.

Keep children and unauthorised persons away from the working area.

DO NOT use the extractor for a task it was not designed to perform.

DO NOT operate the extractor if any parts are damaged or missing as this may cause failure or possible personal injury.

DO NOT get the extractor wet or use in damp or wet locations or areas where there is condensation.

DO NOT allow untrained persons to operate the extractor.

DO NOT operate the extractor when you are tired, under the influence of alcohol, drugs or intoxicating medication.

DO NOT use the extractor where there are flammable liquids, solids or gases such as paint solvents, etc.

DO NOT leave the extractor operating unattended.

When not in use switch the extractor off and remove plug from the power supply.

2. INTRODUCTION & SPECIFICATION

The EFS/93 is a wheeled exhaust extractor for garages and workshops. It is suitable for a range of vehicles from small cars and motorcycles to commercials of up to approximately 10 tonnes GVW. The unit is supplied with 6 metres of exhaust ducting and a cut-away extractor nozzle which provides access to exhausts which are behind the bumper line.

Specification

Motor230V 1ph 0.55kW Extraction rate900m³/h
 Extraction height . .120 to 600mm Weight36kg

3. CONTENT & ASSEMBLY

- 3.1. Unpack the equipment and check for missing or damaged items. In the event of a fault contact the supplier.
 Items
 1. Extractor unit and stand assembly
 2. Extractor nozzle
 3. Exhaust ducting
 4. Jubilee clip
 5. 4 screws and washers (loosely fitted in housing)
- 3.2. Attach extractor nozzle (fig.1.A) to housing (B) with the four screws and washers. Fit exhaust ducting (C) with jubilee clip.

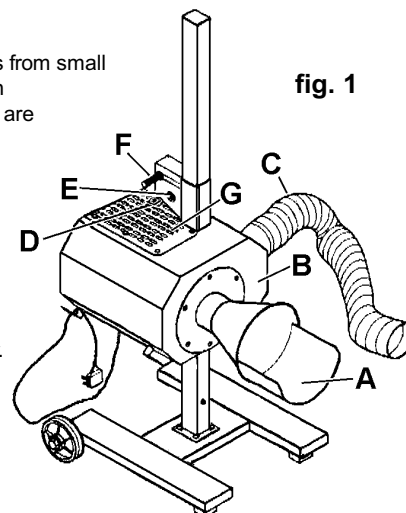

fig. 1

4. OPERATION

WARNING! Before operation the extractor ensure that you have read, understood and apply the safety instructions in Section 1.

- 4.1. To move the extractor, stand behind it, grasp the top of the column and pull towards you so that the unit runs on the rear wheels.
- 4.2. Place the extraction nozzle (fig.1.A) close to the vehicle exhaust pipe, adjusting the extractor height as necessary by rotating grip (fig.1.F) as shown in fig.2 to release and lock the slide. The mechanism is held in the locked position by a spring (fig.2.H).This spring should be checked, through aperture (figs.1 & 2.E), to ensure it is attached at both ends and undamaged before unlocking slide. If the spring is faulty it must be rectified/replaced before further use.
- 4.3. Route the exhaust ducting (fig.1.C) to outside the building, keeping the ducting as straight and level as is practical. Note that the ducting is relatively easily damaged and should be routed, as far as possible, away from walkways etc.
- 4.4. Connect to the mains supply and turn on extractor at switch (fig.1.D).

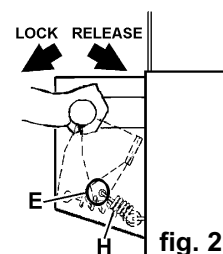

fig. 2

Note: Take care to ensure that there is no possibility of paper, plastic etc. being sucked into the extractor.

5. MAINTENANCE

- 5.1. The extractor requires no specific maintenance other than to keep it clean and free from damage.

6. TROUBLE-SHOOTING

WARNING! Disconnect the unit from the mains power before servicing or performing any maintenance.

PROBLEM	CAUSE	SOLUTION
Extractor does not start	1. No supply 2. Wiring defect 3. Fuse blown	1. Check power supply. 2. Check plug and On/Off switch connections - remove protective grid (fig.1.G) to access switch wiring. 3. a) Check plug fuse. b) Remove protective grid (fig.1.G), open the two fuse holders and check unit fuses. Replace any blown fuse with identical type only (10 x 38mm 4 amp).
The unit does not extract efficiently	1. Blockage (paper, plastic etc.) 2. Fan to motor shaft lock screw loose	1. Remove extractor nozzle (fig.1.A) and clear blockage from fan. 2. Remove extractor nozzle (fig.1.A) and tighten screw.

Declaration of Conformity We, the UK distributor, declare that the product listed below is in conformity with the following standards and directives.

EXHAUST FUME EXTRACTOR
Model EFS/93

98/37/EC Machinery Directive
 73/23/EEC LV Directive
 89/336/EEC EMC Directive



The construction file for this product is held by the Manufacturer and may be inspected on request by contacting Jack Sealey Ltd.

Signed by Mark Sweetman

1st September 1999

For Jack Sealey Ltd. Sole distributor of Sealey Power Products.

NOTE: It is our policy to continually improve products and as such we reserve the right to alter data, specifications and component parts without prior notice.

IMPORTANT: No liability is accepted for incorrect use of product. **WARRANTY:** Guarantee is 12 months from purchase date, proof of which will be required for any claim.

INFORMATION: For a copy of our latest catalogue call us on 01284 757525 and leave your full name and address, including postcode.



Sole UK Distributor, Sealey Group,
 Bury St. Edmunds, Suffolk.



01284 757500



01284 703534

E-mail: sales@sealey.co.uk