

# SEALEY

# POWER TOOLS

## PARTS LIST FOR RANDOM ORBITAL SANDER Model: EDA150.V2

# SEALEY

# POWER TOOLS

## INSTRUCTIONS FOR 150MM DUAL ACTION RANDOM ORBITAL SANDER

### Model: EDA150.V2

Thank you for purchasing a Sealey Product. Manufactured to a high standard this product will, if used according to these instructions and properly maintained, give you years of trouble free performance.

**IMPORTANT:** PLEASE READ INSTRUCTIONS CAREFULLY. NOTE THE SAFE OPERATIONAL REQUIREMENTS, WARNINGS AND CAUTIONS. USE THIS PRODUCT CORRECTLY AND WITH CARE FOR THE PURPOSE FOR WHICH IT IS INTENDED. FAILURE TO DO SO MAY CAUSE DAMAGE AND/OR PERSONAL INJURY AND WILL INVALIDATE THE WARRANTY. PLEASE KEEP INSTRUCTIONS SAFE FOR FUTURE USE.

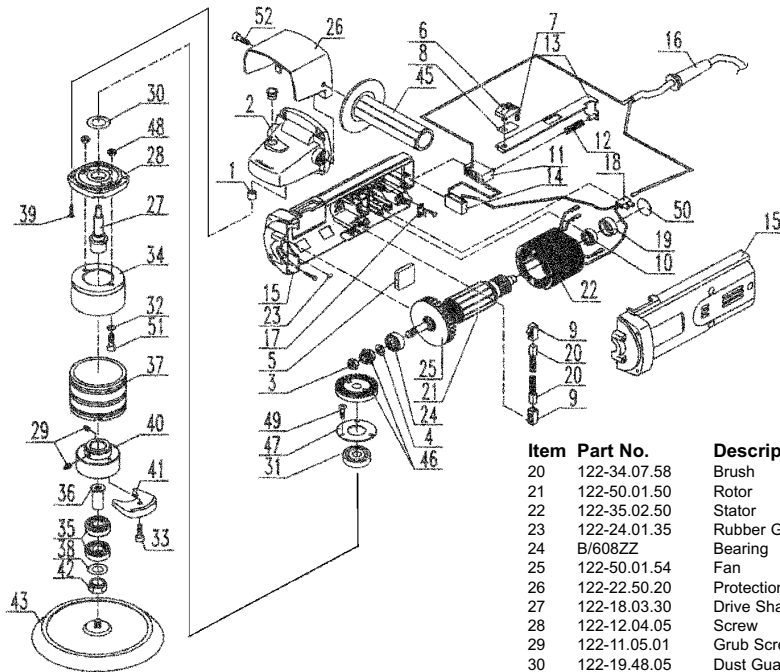

Item	Part No.	Description
1	122-20.01.70	Bush
2	122-10.04.50	Gearbox Housing
3	122-29.01.30	Nut
4	122-19.50.80	Distance Piece
5	122-17.31.50	Field Coil Rubber Packing
6	122-34.06.90	Switch Key
7	122-25.03.50	Switch Spring
8	122-34.06.91	Switch Plate
9	122-34.07.50	Brush Holder
10	B/607ZZ	Bearing
11	122-34.06.92	Switch
12	122-25.03.55	Return Spring
13	122-27.01.30	Switch Lever
14	122-34.03.20	Capacitor
15	122-10.04.55	Plastic Body
16	122-34.04.05	Cable Guard
17	122-34.04.10	Cable Grip
18	122-34.05.05	Terminal Block
19	122-34.08.05	Rubber Cover

Issue: 1  
Date Issued: 300403

Item	Part No.	Description
20	122-34.07.58	Brush
21	122-50.01.50	Rotor
22	122-35.02.50	Stator
23	122-24.01.35	Rubber Grip
24	B/608ZZ	Bearing
25	122-50.01.54	Fan
26	122-22.50.20	Protection Cover
27	122-18.03.30	Drive Shaft
28	122-12.04.05	Screw
29	122-11.05.01	Grub Screw, M6x8
30	122-19.48.05	Dust Guard
31	B/6000ZZ	Bearing
32	122-13.01.11	Lock Washer
33	122-11.06.05	Screw, 5x16
34	122-22.07.10	Protector
35	B/6001-2RS	Bearing
36	122-32.01.13	Eccentric Body Shaft
37	122-24.04.40	Rubber Protection
38	122-19.50.02	Dust Guard
39	122-11.07.01	Screw, M4x14
40	122-32.03.13	Eccentric Body
41	122-14.06.15	Counterbalance
42	122-32.01.24	Hex Eccentric Shaft
43	122-20.00.23A	Sanding Pad
45	122-10.03.50	Side Handle
46	122-16.50.10	Gear Set
47	122-19.48.10	Bearing Cover
48	122-29.01.11	Nut
49	122-11.03.17	Screw, M4x10
50	122-21.04.30	Sealing Cap
51	122-11.06.18	Screw, M5x12
52	122-11.10.05	Plastic Screw

**NOTE:** It is our policy to continually improve products and as such we reserve the right to alter data, specifications and component parts without prior notice.

**IMPORTANT:** No liability is accepted for incorrect use of this equipment. **WARRANTY:** Guarantee is 12 months from purchase date, proof of which will be required for any claim. **INFORMATION:** For a copy of our latest catalogue and promotions call us on 01284 757525 and leave your full name and address, including postcode.

**SEALEY POWER TOOLS** Sole UK Distributor,  
Sealey Group,  
Bury St. Edmunds, Suffolk.

01284 757500  
01284 703534

www.sealey.co.uk  
sales@sealey.co.uk

## 1. SAFETY INSTRUCTIONS

### 1.1. Electrical Safety

**WARNING!** It is the responsibility of the owner and the operator to read, understand and comply with the following. You must check all electrical products, before use, to ensure that they are safe. You must inspect power cables, plugs, sockets and any other connectors for wear or damage. You must ensure that the risk of electric shock is minimised by the installation of appropriate safety devices. A Residual Current Circuit Breaker (RCCB) should be incorporated in the main distribution board. We also recommend that a Residual Current Device (RCD) is used. It is particularly important to use an RCD with portable products that are plugged into a supply which is not protected by an RCCB. If in any doubt consult a qualified electrician. You may obtain a Residual Current Device by contacting your Sealey dealer.

You must also read and understand the following instructions concerning electrical safety.

- 1.1.1. The **Electricity at Work Act 1989** requires that all portable electrical appliances, if used on business premises, are tested by a qualified electrician, using a Portable Appliance Tester (PAT), at least once a year.
- 1.1.2. The **Health & Safety at Work Act 1974** makes owners of electrical appliances responsible for the safe condition of those appliances and the safety of the appliance operators. **If in any doubt about electrical safety, contact a qualified electrician.**
- 1.1.3. Ensure that the insulation on all cables and on the appliance is safe before connecting to the power supply. See 1.1.1. and 1.1.2. and use a Portable Appliance Tester.
- 1.1.4. Ensure that cables are always protected against short circuit and overload.
- 1.1.5. Regularly inspect power supply cables and plugs for wear or damage and check all connections to ensure that none is loose.
- 1.1.6. **Important:** Ensure that the voltage marked on the appliance matches the power supply to be used and that the plug is fitted with the correct fuse - see fuse rating at right.
- 1.1.7. **DO NOT** pull or carry the appliance by the cable.
- 1.1.8. **DO NOT** pull the plug from the socket by the cable.
- 1.1.9. **DO NOT** use worn or damaged cables, plugs or connectors. Immediately have any faulty item repaired or replaced by a qualified electrician. When a BS 1363/A UK 3 pin plug is damaged, cut the cable just above the plug and **dispose of the plug safely.**
  - a) **Connect the BROWN live wire to the live terminal 'L'.**
  - b) **Connect the BLUE neutral wire to the neutral terminal 'N'.**
  - c) **After wiring, check that there are no bare wires, that both wires have been correctly connected, that the cable outer insulation extends beyond the cable restraint and that the restraint is tight.**

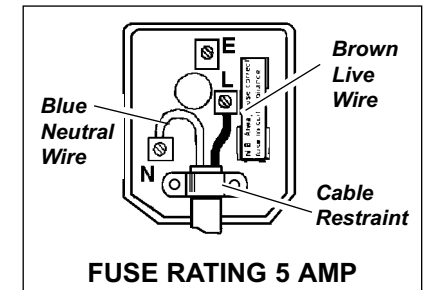

- 1.1.10. This product is double insulated and is not earthed - **DO NOT** connect either wire to the earth terminal.
- 1.1.10. If an extension reel is used it should be fully unwound before connection. A reel with an RCD fitted is preferred since any appliance plugged into it will be protected. The cable core section is important and should be at least 1.5mm<sup>2</sup>, but to be absolutely sure that the capacity of the reel is suitable for this product and for others which may be used in the other output sockets, we recommend the use of 2.5mm<sup>2</sup> section cable.

## 1.2. General Safety

- ❑ **WARNING!** Ensure that Health & Safety, local authority, and general workshop practice regulations are adhered to when using this equipment.
- ❑ **WARNING!** Disconnect from mains power before changing accessories or carrying out servicing or maintenance.
- ✓ Maintain the sander in good condition (use an authorised service agent).
- ✓ Replace or repair damaged parts. Use recommended parts only. Unauthorised parts may be dangerous and will invalidate the warranty.
- ✓ Use the sander in a suitable work area and keep the area clean, tidy and free from unrelated materials. Ensure that there is adequate lighting.
- ✓ Before use check abrasive pad condition. If worn or damaged replace immediately.
- ❑ **WARNING!** Always wear approved eye or face protection when operating the sander.
- ✓ If dust is generated, use face, dust, or respiratory protection in accordance with COSHH regulations.
- ✓ Depending on task, sander noise level may exceed 85dB, in which case wear safety ear defenders.
- ✓ Remove ill fitting clothing, ties, watches, rings and other loose jewellery, and contain and/or tie back long hair.
- ✓ Wear appropriate protective clothing and keep hands and body clear of the sanding disc.
- ✓ Maintain correct balance and footing. Ensure the floor is not slippery and wear non-slip shoes.
- ✓ Keep children and unauthorised persons away from the work area.
- ✓ Always use the sander with the side handle securely assembled.
- ✓ Ensure that the workpiece is correctly secured before operating the sander. Never hold the workpiece by hand. Check the workpiece to ensure that there are no protruding nails, screws, stones, etc.
- ✓ Avoid unintentional starting.
- x DO NOT use the sander for a task that it is not designed to perform.
- x DO NOT operate the sander if any parts are damaged or missing. To do so may cause failure and/or injury.
- ❑ **WARNING!** DO NOT sand any materials containing asbestos.
- x DO NOT carry the sander by the electrical cable.
- x DO NOT get the sander wet or use in damp or wet locations.
- x DO NOT use the sander with water, this model is a dry sander only.
- x DO NOT place attachments close to your face and do not point at other persons or animals.
- x DO NOT operate the sander if you are tired or under the influence of alcohol, drugs or intoxicating medication.
- x DO NOT use near flammable liquids, solids or gases such as paint solvents and including waste wiping or cleaning rags etc.
- x DO NOT leave the sander operating unattended.
- x DO NOT carry the sander with your finger on the power switch.



## 1.3. LEAD PAINT WARNING!



Paint once contained lead as a traditional ingredient. Dust from the removal of such paint is toxic and contact with it must be avoided. The following action must be taken when using the sander on paint that you suspect may contain lead.

1. User must determine potential hazard relating to age of paint to be removed (modern paints do not contain lead).
2. **DANGER!** Keep all persons and pets away from the work area. The following are particularly vulnerable to the effects of lead paint dust: *Pregnant women, babies and children.*
3. We recommend personal protection by using the following safety items:
  - a) Paint Spray Respirator (Our ref SSP1619)
  - b) PE Coated Hooded Coverall (Our ref SSP266)
  - c) Latex Gloves (Our ref SSP24).
4. Take adequate measures to contain the paint dust, flakes and scrapings.
5. Continue to wear safety equipment as in (3) above and thoroughly clean all areas when the task is complete.
6. Ensure that paint waste is disposed of, according to local regulations, in sealed bags or containers.

## 2. ASSEMBLY & SPECIFICATION

The EDA150 has an alloy bevel gear head with composite motor housing and carbon brush caps for quick brush replacement. Slider type power control with power lock. Supplied with side handle and Ø150mm backing pad.

### 2.1. Assembly

- ❑ **WARNING!** DO NOT plug sander into the mains power supply before the machine is assembled.

Unpack the sander and check contents against fig. 1. If there are any damaged or missing parts, contact your supplier immediately.

Screw the side handle (2) into the head (1) on the required side having first removed the appropriate head shield screw. Screw the sanding pad (3) into the underside of the rotating head (B). To remove the pad, hold the spindle nut with the wrench (4) provided.

### 2.2. SPECIFICATION

Power .....	.360W
Power Input .....	.230V - 1.6A
No Load Speed .....	.7000rpm
Orbit .....	.8mm
Thread .....	.5/16"UNF
Pad Diameter .....	.150mm
Weight .....	.2.1kg

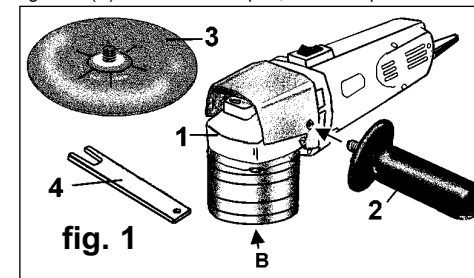

## 3. OPERATING INSTRUCTIONS

- ❑ **WARNING!** Before use, ensure you read, understand and apply Section 1 safety instructions. The sander is designed for dry use only. DO NOT use with water or any other liquids.

- 3.1. Attach correctly rated sanding disc to the self-adhesive sanding pad.
- 3.2. Plug the sander into the mains power supply.
- 3.3. Grip the side handle and turn on by pushing switch (fig. 2.A) down and forward. Let go of the switch and the unit will be locked on.
- 3.4. To turn off sander, depress the switch and pull it back.

**Note:** Check that the unit is working correctly before use.

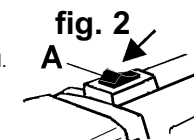

## 4. MAINTENANCE

- ❑ **WARNING!** Disconnect sander from mains power supply before changing accessories, servicing or performing maintenance. Replace or repair damaged parts. Use recommended parts only. Unauthorised parts may be dangerous and will invalidate the warranty.
- 4.1. Clean the underside of the sanding head after use. Use an air line to blow dust out from around the motor by passing the air through the ventilation holes.
  - 4.2. Change pads when required.
  - 4.3. Check brushes after every 200 hours of use and replace when at 5mm.
  - 4.4. All other service and maintenance must be carried out by an authorised service agent.
  - 4.5. When not in use store in a safe, dry, childproof location.

## 5. DECLARATION OF CONFORMITY

**Declaration of Conformity** We, the sole importer into the UK, declare that the product listed here is in conformity with the following standards and directives. The construction file for this product is held by the Manufacturer and may be inspected, by a national authority, upon request to Jack Sealey Ltd.

**150mm DUAL ACTION RANDOM ORBITAL SANDER**  
**Model: EDA150.V2**

73/23/EEC Low Voltage Directive  
89/336/EEC EMC Directive  
93/68/EEC CE Marking Directive



Signed by Mark Sweetman

1st May 2003

For Jack Sealey Ltd. Sole importer into the UK of Sealey Power Tools.