



400/75A 12/24V ELECTRONIC STARTER/ CHARGER/MAINTAINER

MODEL NO: **ECS400**

Thank you for purchasing a Sealey product. Manufactured to a high standard, this product will, if used according to these instructions, and properly maintained, give you years of trouble free performance.

IMPORTANT: PLEASE READ THESE INSTRUCTIONS CAREFULLY. NOTE THE SAFE OPERATIONAL REQUIREMENTS, WARNINGS & CAUTIONS. USE THE PRODUCT CORRECTLY AND WITH CARE FOR THE PURPOSE FOR WHICH IT IS INTENDED. FAILURE TO DO SO MAY CAUSE DAMAGE AND/OR PERSONAL INJURY AND WILL INVALIDATE THE WARRANTY. KEEP THESE INSTRUCTIONS SAFE FOR FUTURE USE.



Refer to instructions



Wear eye protection



Wear protective gloves



Electrical shock hazard



Warning: corrosive substance



Warning: explosive material



Keep away from sources of ignition

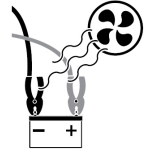

Use in well ventilated areas



Keep in dry area
protect from rain

1. SAFETY

1.1. ELECTRICAL SAFETY

- WARNING!** It is the responsibility of the owner and the operator to read, understand and comply with the following:
- ✓ You must check all electrical products, before use, to ensure that they are safe. You must inspect power cables, plugs, sockets and any other connectors for wear or damage. You must ensure that the risk of electric shock is minimised by the installation of appropriate safety devices. A Residual Current Circuit Breaker (RCCB) should be incorporated in the main distribution board. We also recommend that a Residual Current Device (RCD) is used. It is particularly important to use an RCD with portable products that are plugged into a supply which is not protected by an RCCB. If in any doubt consult a qualified electrician. You may obtain a Residual Current Device by contacting your Sealey dealer.
- You must also read and understand the following instructions concerning electrical safety.
- ✓ The Electricity at Work Act 1989 requires that all portable electrical appliances, if used on business premises, are tested by a qualified electrician, using a Portable Appliance Tester (PAT), at least once a year.
- ✓ The Health & Safety at Work Act 1974 makes owners of electrical appliances responsible for the safe condition of those appliances and the safety of the appliance operators.
- If in any doubt about electrical safety, contact a qualified electrician.
- ✓ Ensure that the insulation on all cables and on the appliance is safe before connecting it to the power supply. See 1.1.1. and 1.1.2. and use a Portable Appliance Tester.
- ✓ Ensure that cables are always protected against short circuit and overload.
- ✓ Regularly inspect power supply leads and plugs for wear and damage and power connections to ensure that none is loose or damaged.
- ✓ Ensure that the voltage marked on the appliance matches the power supply to be used and that the plug is fitted with the correct fuse - see fuse rating at right.
- ✗ **DO NOT** pull or carry the appliance by the power cable.
- ✗ **DO NOT** use worn or damaged cables, plugs or connectors. Immediately have any faulty item repaired or replaced by a qualified electrician.
- ✗ This product requires an electrical supply in excess of 13 amp, and NO plug is fitted. You must therefore contact a qualified electrician to ensure that a 16 amp supply is available. We recommend that you discuss the installation of a industrial round pin plug and socket with your electrician. Ensure that the unit is correctly earthed via a three-pin plug, as shown.
 - a) Connect the GREEN/YELLOW earth wire to the earth terminal. 
 - b) Connect the BROWN live wire to live terminal 'L'.
 - c) Connect the BLUE neutral wire to the neutral terminal, 'N' or unmarked.
 - d) After wiring, check that there are no bare wires, that all wires have been correctly connected, that the external insulation extends beyond the cable restraint and that the restraint is tight.
- ✓ If an extension reel is used it should be fully unwound before connection. A reel with an RCD fitted is preferred since any appliance plugged into it will be protected. The cable core section is important and should be at least 1.5mm², but to be absolutely sure that the capacity of the reel is suitable for this product and for others which may be used in the other output sockets, we recommend the use of 2.5mm² section cable.

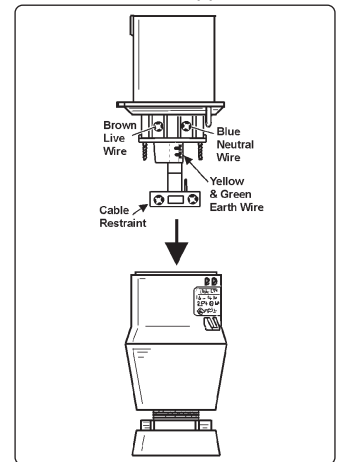

**IT IS RECOMMENDED THAT
THE SUPPLY TO THIS PRODUCT
IS FITTED WITH A
32AMP FUSE OR BREAKER**

- ❑ **WARNING!** Modern vehicles contain extensive electronic systems.
You are required to check with the vehicle Manufacturer, for any specific instructions regarding the use of this type of equipment on each vehicle. No liability will be accepted for damage / injury, where this product is not used in accordance with all instructions.
 - ▲ **DANGER! BE AWARE, LEAD-ACID BATTERIES GENERATE EXPLOSIVE GASES DURING NORMAL BATTERY OPERATION. FOR THIS REASON, IT IS VERY IMPORTANT TO READ AND FOLLOW THESE INSTRUCTIONS CAREFULLY EACH TIME YOU USE THE CHARGING EQUIPMENT.** Follow these instructions and those published by the battery manufacturer and the maker of any equipment you intend to use in the vicinity of the battery. Remember to review warning marks on all products and on engines.
- 1.2. **Personal Precautions**
- ✓ When working with or near a lead-acid battery ensure there is another person within hearing range and close enough to come to your aid, should a problem arise.
 - ✓ Wear safety eye protection and protective clothing. Avoid touching eyes while working near battery.
 - ✓ Have fresh water and soap nearby in case battery acid contacts skin, clothing, or eyes.
 - ✓ Wash immediately with soap and water if battery acid contacts skin or clothing. If acid enters eye, flush eye immediately with cool, clean running water for at least 15 minutes and seek immediate medical attention.
 - ✓ Remove personal metallic items such as rings, bracelets, necklaces and watches. A lead-acid battery can produce a short-circuit current high enough to weld a ring or the like to metal, which may cause severe burns.
 - ✓ Ensure hands and clothing, including belts, are clear of fan blades and other moving or hot parts of the engine. Remove ties and contain long hair.
 - ✗ **DO NOT** smoke or allow a spark or flame in the vicinity of the battery or the engine.
- 1.3. **General Safety Instructions**
- ✓ Familiarise yourself with the applications, limitations and potential hazards relating to the starter/charger. Also refer to the vehicle manufacturer's handbook. **IF IN ANY DOUBT CONSULT A QUALIFIED ELECTRICIAN.**
 - ✓ Ensure the starter/charger is in good order and condition before use. If in any doubt, do not use the unit and contact an electrician.
 - ✓ Only use genuine parts. To use unapproved parts may be dangerous and will invalidate your warranty.
 - ✓ Use the starter/charger in the horizontal position only and ensure it stands on a stable surface which will adequately support the weight.
 - ✓ Ensure the charger is switched off and disconnected from the mains power supply before attaching the power clamps to the battery.
 - ✓ Keep tools and other items away from the engine and ensure that you can see the battery and working parts of the engine clearly.
 - ✓ If the battery has removable caps to access the battery fluid, remove the caps and check the fluid level before connecting the power leads.
If necessary top-up the battery with distilled water by referring to the battery manufacturer's instructions, (apply the personal safety precautions described in para. 1.2.).
 - ✗ **DO NOT** dis-assemble the starter/charger for any reason. It must be checked by qualified service personnel only.
 - ✓ The cables may become hot with excessive use. If so, allow a few minutes for them to cool down before attempting to re-use.
 - ✓ If the starter/charger receives a sharp knock or blow, the unit must be checked by a qualified service agent before using.
 - ✓ When not in use, store the starter/charger carefully in a safe, dry, childproof location.
 - ✓ Ensure the positive cable is connected to the correct voltage connection on the charger as for the voltage of the battery being charged.
 - ✓ Keep children and unauthorised persons away from the work area.
 - ✗ **DO NOT** try to charge a non-rechargeable battery.
 - ✗ **DO NOT** try to start with a frozen battery. **DO NOT** attempt to charge a frozen battery.
 - ❑ **WARNING! DO NOT** allow metal tools to touch both battery terminals at the same time. The resulting spark or short circuit may cause an explosion.
 - ✗ **DO NOT** pull the cables or clamps from the battery terminals.
 - ✗ **DO NOT** use this product to perform a task for which it is not designed.
 - ❑ **WARNING! DO NOT** simultaneously charge different types of batteries.
 - ❑ **WARNING! DO NOT** If a fuse blows, ensure that it is replaced with one of identical type and rating.
 - ✓ If the battery terminals are corroded or dirty, clean them before attaching the starter/charger clamps.
 - ✗ **DO NOT** use the starter/charger outdoors, or in damp, or wet locations, and **DO NOT** operate within the vicinity of flammable liquids or gases.
 - ✗ **DO NOT** situate charger inside a vehicle or under the vehicle bonnet. Ensure that there is sufficient ventilation and **DO NOT** cover or obstruct the starter/charger ventilation louvres.
 - ✗ **DO NOT** allow clamps to touch each other or to make accidental contact with any part of the vehicle.
 - ✗ **DO NOT** cross-connect power leads from starter/charger to the battery. Ensure positive (+ RED) is to positive and negative (- BLACK) is to negative. If symbols cannot be distinguished, remember that the negative terminal is normally the one directly connected to the vehicle bodywork.
- NOTE:** This appliance can be used by children aged from 8 years and above and persons with reduced physical, sensory or mental capabilities or lack of experience and knowledge if they have been given supervision or instruction concerning use of the appliance in a safe way and understand the hazards involved. Children shall not play with the appliance. Cleaning and user maintenance shall not be made by children without supervision.

2. INTRODUCTION

Fully electronic, microprocessor controlled battery starter/charger designed to meet the requirements of modern battery technology. Suitable for EFB & AGM/GEL (stop/start), Lead Acid, Lead Calcium & Silver Calcium batteries found on electric and hybrid vehicles. Features up to ten analysis and charge phases, including trickle/maintenance and suitable for 12V & 24V electrical systems. Instant visual check of battery condition, charge current, voltage and charging rate via LED read-out. Stabilised charging current allows improved charging efficiency and reduced charging times using ECS (Electronic Control Systems) technology. Includes circuitry to provide surge and spike protection during charging and starting, preventing damage to vital systems such as ABS, airbag sensors, ignition and music systems. Features power supply mode, providing support for the battery to prevent it from being drained during prolonged electronic diagnostic checks and software updates.

3. SPECIFICATION

Output Voltage:12/24V
Output Charge Peak (EN)75A(50A)
Output Start Peak (EN)400A(300A)
Battery Range4-550Ah
Input Charge1.5KW-6.5A
Input Start10KW-43A
Charging Rates	... 3xPreset+1XVariable to Current Max.
Supply230V -32A
BSU30A-13.5V
Polarity ProtectionFuse (2x100A)
Fuse120/802131 (Pack of 10), 120/122452 (single)

4. ASSEMBLY

- 4.1. Carefully unpack all components and prepare a surface on which you can lay the unit down on during assembly, without damaging it.
- 4.2. Insert the handle (fig.1.1) and secure it through the rear of the unit with screws (fig.1.2).
- 4.3. Screw on the clamp holders to each side (fig.1.3).
- 4.4. Use the long screws to screw on the cable retainers and spacers on each side (fig.1.4).
- 4.5. Lay the unit on its front in order to insert the axle. Fit the wheels (fig.1.5), then their retainers and caps (fig.1.6).
- 4.6. Clamp Assembly (fig.2).
 - 4.6.1. Push cable through insulating handles.
 - 4.6.2. Locate cable using cable screw washer and nut, note which way up cable needs to be. Screw on cable clamp tightly.
 - 4.6.3. Screw up cable screw tightly.
 - 4.6.4. Push outer protection pieces onto the ends of the clamp.
 - 4.6.5. Slide insulating handles up to meet the outer protection pieces.
 - 4.6.6. Repeat for all four clamps.

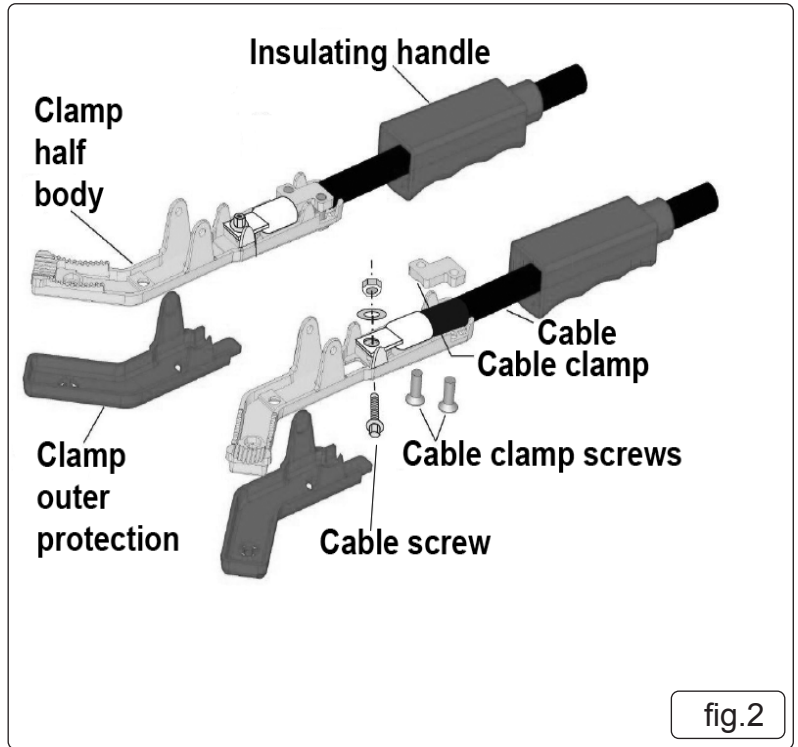
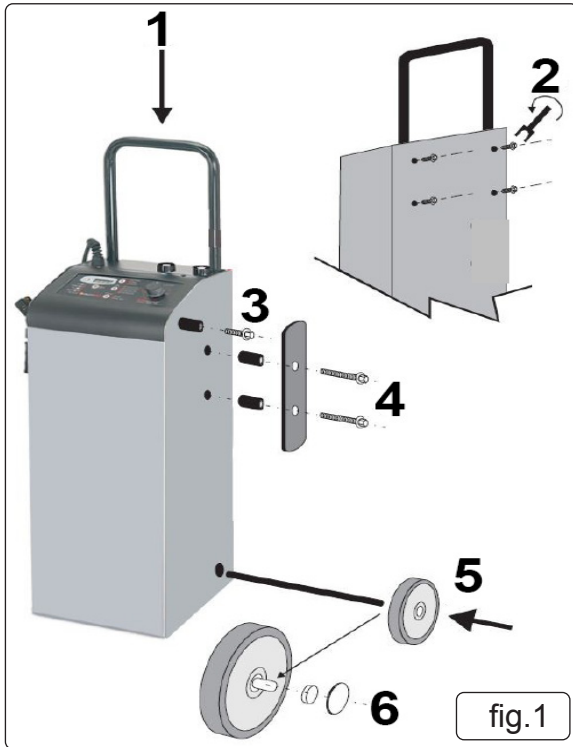

Data Plate	
CE Marking	Do Not Use In The Rain
Ingress Protection Rating	Class 1
Relevant Standards	Model No. XXX
Input Voltage	Output Fuse Rating
Input Power (Charge)	Insulation Class
Output Voltage	Transformer has Thermal Protection
Electrical Output Ratings	Input Fuse Rating
Start Mode Cycle	Input Power (Start)
Minimum Battery Capacity	Electrical Output Ratings
	Suitable Battery Capacity Range

5. CONTROL PANEL

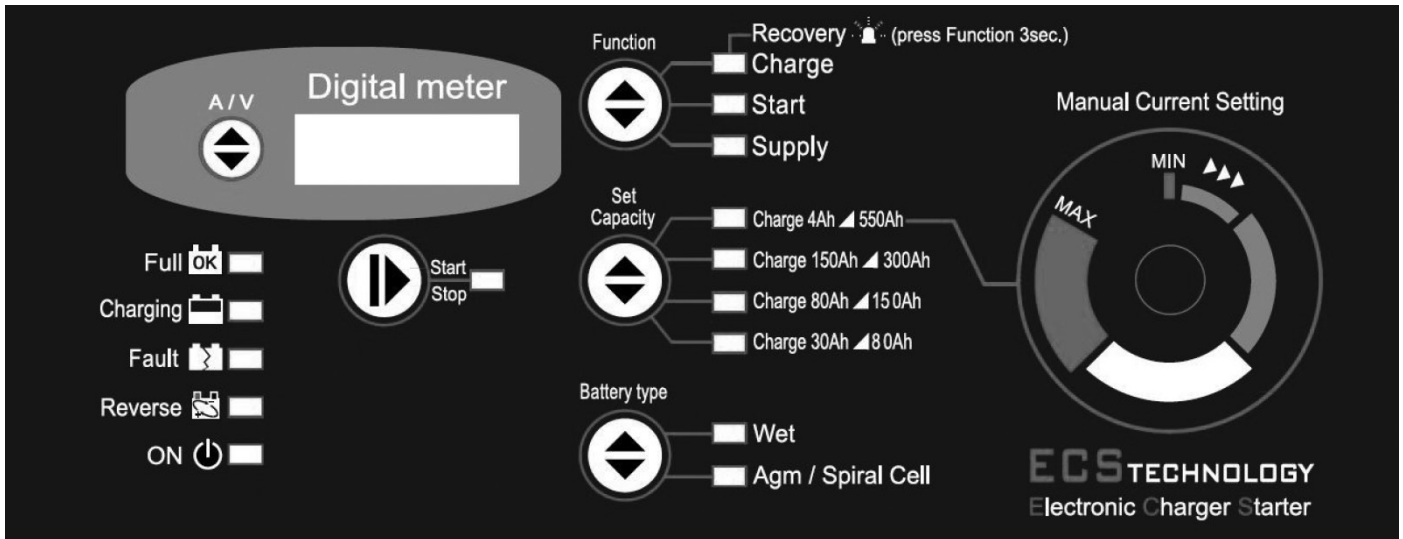

5.1. SIGNALLING LEDS

There are 15 LEDs on the front panel having the following functions:

- 4 battery status LEDs, indicating:
 - Full: battery is charged and is in Charge Maintenance status.
 - Charging: battery charging.
 - Fault: battery is damaged.
 - Reverse: polarity reversal.
- 1 battery charger status LED: ON LED, battery charger ON (colour BLUE).
- 1 operating status LED: indicates whether output is in accordance with selected mode. Correlated with the Start/Stop button (Colour YELLOW).
- 3 LEDs on Function operating mode: Charge, Start or Supply (colour YELLOW)
- 4 battery capacity indication LEDs: Set Capacity described in section 6.2. (colour YELLOW).
- 2 battery type indication LEDs: Battery Type described in section 6.3. (colour YELLOW).

5.2. OPERATING MODE SELECTION BUTTONS

There are 5 buttons on the front panel which have the following functions:

- Start / Stop: starts or stops supply in the selected mode.
- Function: selects operating mode.
- Set Capacity: selects battery capacity.
- Battery Type: selects the type of battery to charge.
- A/V: selects the information to be displayed.

5.3. DIGITAL DISPLAY

5.3.1. A/V button: The A/V selector button selects voltage or current display or allows the user to change the display language.

Pressing the A/V button toggles from voltage display U to current display A, and finally the Language menu. This menu will show the message "LANGUAGE = ITALIAN" or another language, depending on the selection.

5.3.2. Change Display Language.

To enter the language selection mode, press the A/V button and hold it down when the display is showing the message "LANGUAGE = ITALIAN". The language setting is Italian by default; to scroll the language menu press the A/V button again and the language shown will change instantly. Languages supported: • Italian • English. Once the language is set, to quit the menu press the A/V button for a few seconds.

6. OPERATING MODES

6.1. FUNCTION

Note: All modes support both 12V and 24V batteries (voltages stated for 12V batteries).

6.1.1. CHARGE MODE

Battery charging mode. Provides 11 charging steps as described below:

- **STEP 1:** Analysis 1: If the battery output is less than 10.5V the unit proceeds with the next analysis. Outputs below 5V will cause the charger to revert to stand-by.
- **STEP 2:** Analysis 2 (sulphated battery): The display shows the message "ANALYSIS" alternating with the instantaneous voltage or current. After this step the unit either starts the charging cycle directly or it displays the message "SULPHATED BATTERY" to inform the operator that the battery must be recovered.
- **STEP 3:** Desulphation: Pulsed voltage to prevent sulphation of the battery.
- **STEP 4:** Controlled current: Charges the battery up to the programmed limit value.
- **STEP 5:** Analysis 3 (elements short circuited): Checks whether the battery has short circuited elements or is damaged and reports the error, if present.
- **STEP 6:** Deep Cycle Charging: Central charging cycle.
- **STEP 7:** Constant Voltage: Keeps the battery at the charging end voltage.
- **STEP 8:** Analysis 4: Checks whether the battery has short circuited elements or is damaged and reports the error, if present.
- **STEP 9:** Trickle charging: Maintains the battery at 13.8V (WET) or 13.5V (AGM/SPIRAL CELL).
- **STEP 10:** Analysis 5: Checks whether the battery has short circuited elements or is damaged and reports the error, if present.
- **STEP 11:** Pulsed current cycle: Cycle that simulates the normal life cycle of the battery.

6.1.2. START MODE

To start a vehicle with a flat battery, this mode consists of the following steps:

- **STEP 1:** Battery analysis: The charger's Start LED flashes.
- **STEP 2:** Fast Charging: The charger enters this step if the Start LED is steadily on. It sets the charge end voltage associated with the selected battery type with the current limit defined for the Start step.
- **STEP 3:** Engine Boost: When the battery charger detects an engine cranking attempt, it switches to the next step. If the battery voltage reading is above 13.5V the scrolling message START appears on the display.
- **STEP 4:** Boost: The scrolling message START appears on the display: the battery charger is now delivering the maximum power.

6.1.3. SUPPLY MODE

Power supply mode to assist in vehicle programming. This mode does not contain any charging steps, and it consists exclusively of a stabilised power supply delivering the nominal battery voltage. The purpose is that of supplying current to support the battery to prevent it from being drained during operations that require power for short or long periods.

6.1.4. RECOVERY MODE

- **WARNING:** because of the high voltage reached during this cycle, the battery recovery process MUST be performed with the battery disconnected and removed from the vehicle. Recovery with the battery connected to the vehicle may result in damage to the vehicle's electronics.

This is the method of recovery for sulphated batteries accessible by means of a prolonged press of 3 seconds of the Function button. The screen displays the message RECOVERY alternating with the instantaneous voltage or current reading; during this step the Charge LED flashes.

The charger performs a special charging cycle in which higher than average voltages are forced to attempt recovery of the battery. In this mode no error messages are generated during the charging cycle.

At the end of the cycle a message is displayed to indicate whether or not the battery has been recovered on the basis of the current absorption.

This mode has six steps as described below:

- **STEP 1:** Analysis 1: Outputs below 1.5V will cause the device to revert to standby.
- **STEP 2:** Desulphation: Pulsed voltage in order to prevent sulphation of the battery.
- **STEP 3:** Controlled Current: Charges the battery up to the programmed limit value.
- **STEP 4:** Deep Cycle Charging: Central Charging Cycle.
- **STEP 5:** High Voltage: Keeps the battery at high voltage for 2 hours to attempt to break down the sulphate crystals that have formed in the battery.
- **STEP 6:** Analysis 2: Checks whether or not the battery has been recovered.

6.2. CHARGING MODE

6.2.1. Set Capacity.

Preset charging bands to select the connected battery, or for expert users, manual setting of the output current as a percentage of the maximum current supported by the operating mode currently selected on the battery charger Manual Current Setting.

Specifically:

- Charge: settable charging band.
- Start: settable charging band.
- Supply: settable supply band, by Manual Current Setting.

Charge 4Ah - 550Ah (Manual).

Supports all batteries from a minimum of 4Ah up to a maximum of 550Ah.

Output current is adjustable from 0 up to the maximum supported by the operating mode currently selected on the battery charger.

Charge 150Ah - 300Ah.

Supports batteries from 150Ah up to 300Ah. Output current adjusted automatically.

Charge 80Ah - 150Ah.

Supports batteries from 80Ah up to 150Ah. Output current adjusted automatically.

Charge 30Ah - 80Ah.

Supports batteries from 30Ah - 80Ah. Output current adjusted automatically.

6.3. BATTERY TYPE

Wet: Acid electrolyte batteries.

Agm-Spiral Cell:AGM batteries with flat plate or Optima type spiral cell.

6.4. SAVING SETTINGS

The battery charger saves the settings made on the control panel. In the event of an accidental power loss or voluntary power off, when the charger is restarted, it will restart with the latest saved settings, including the Start/Stop status

6.5. BATTERY ANALYSIS

The analysis stages within the operating modes may terminate with the signalling of various errors:

- **Damaged Battery:** the Fault LED switches on and the Start/Stop LED switches off and the charger enters Standby mode. The display shows the message Errxx where xx is the number corresponding to the cause of the error (see table). Single 10 second audible warning.
- **Polarity reversal:** the Reverse LED switches on and the display shows the message Err07 with a two second audible warning.
- **Analysis step in: Charge:** the display shows the scrolling message ANALYSIS alternating with the measured voltage or current value; the LED corresponding to the function continues to flash until the analysis is concluded. If the battery is in good condition, the LED will be on, otherwise the display shows scrolling message SULPHATED BATTERY and an intermittent audible warning is emitted.
- **Analysis step in: Start:** in the preliminary analysis function in Start, the LED of this mode will flash until a current absorption exceeding a minimum threshold is detected, after which the LED remains on and the vehicle engine can be started.

6.6. ERROR CODES

Display Indication	Cause	Solution
Err01	Leads disconnected, leads short-circuited.	Position the clamps correctly and start charging the battery again; (see section: 7.2. Operating the Charger).
	Battery completely short-circuited.	The battery could be defective. Contact your nearest battery service centre.
Err02	Battery faulty or unrecoverable No current accepted after 10 hours of recovery.	The battery could be defective. Contact your nearest battery service centre.
Err03	Internal overheating of battery charger Battery charger overload.	Remove any objects that could be covering the ventilation area of the battery charger or move it to a cooler area. Wait for the battery charger to start again automatically.
Err04	Tension Error.	Set again the voltage corresponding to that of the battery. Start charging the battery again (see section: 7.2. Operating the Charger).
	One or more elements of the battery has/have short-circuited.	The battery could be defective. Contact your nearest battery service centre.
Err05	Battery voltage too high compared to that set. (You are attempting to charge a 24V battery with the battery charger set at 12 Volt).	Set again the voltage corresponding to that of the battery. Start charging the battery again (see section: 7.2. Operating the Charger).
Err06	Battery capacity excessive Unable to reach end condition.	Use a battery charger with greater capacity.
Err07 and LED REVERSE	The clamps of the output leads are not connected correctly to the battery.	Position the clamps correctly and start charging the battery again (see section: 7.2. Operating the Charger).
Err08	Excessively high output current Current exceeds maximum limit.	Reduce output current when in manual mode.

7. OPERATION

7.1. CHARGING CONNECTIONS

- 7.1.1. Charging batteries connected to the vehicle.
- 7.1.2. Before starting to charge the battery, make sure the power supply lead is **NOT** plugged into the mains supply.
- 7.1.3. Locate the vehicle's earthing point, which is normally connected to the negative battery terminal.
- 7.1.4. Charging a battery with negative earth, grounded to the vehicle's chassis:
- Connect the output lead with red clamp to the positive terminal (+) of the battery.
 - Connect the output lead with black clamp to the vehicle's earthing point, keeping it away from the battery and from the fuel pipes etc.
- NOTE:** If connecting to an older vehicle, it may be positively earthed, in which case the clamps need to be connected in reverse.
- 7.1.5. Charging batteries that are not connected to a vehicle.
- 7.1.6. Before starting to charge the battery, make sure the power supply lead is NOT plugged into the mains supply.
- 7.1.7. Connect the output lead with red clamp to the positive terminal (+) of the battery.
- 7.1.8. Connect the output lead with black clamp to the negative terminal (-) of the battery.
- ATTENTION:** Make sure both clamps of the output leads generate a suitable contact with their corresponding terminals.

7.2. OPERATING THE BATTERY CHARGER

- 7.2.1. Once the output leads are connected to the battery, check that the positive lead is connected correctly to either the 12V or 24V connector on the charger as required. Then plug the power supply lead of the battery charger into the mains supply, making sure that the voltage matches the nominal voltage of the battery charger (230V-50Hz); having done this, the charger will emit an acoustic signal for ½ second and all the LED indicators on the control panel will switch on for 2 seconds, the digital display shows ----.
- 7.2.2. The battery charger is configured in Standby mode, for example: ON LED lit, Charge lit, Wet LED lit. The LEDs light up differently based on the last program saved (see section 6.4. Saving Settings).
- 7.2.3. At this stage, with the battery charger in Standby mode, set the charging parameters suitable for the type of battery to be charged, using the buttons on the control panel. The charging parameters selected are displayed by the corresponding LED, which switches on.
- 7.2.4. Settable charging parameters:
- Function key: Charge, Start, Supply, Recovery.
 - Set Capacity key: Based on the capacity of the battery and on the work cycle, select:
 - Charge 30Ah/80Ah: Charge for batteries with capacity from 30Ah to 80Ah.
 - Charge 80Ah/150Ah: Charge for batteries with capacity from 80Ah to 150Ah.
 - Charge 150Ah/300Ah: Charge for batteries with capacity from 150Ah to 300Ah.
 - Charge 4Ah/550Ah: Supports all batteries from a minimum capacity of 4Ah up to a maximum of 550Ah.
- Adjust the output current from 0 up to the maximum supported by the operating mode currently selected on the charger using the dial on the right of the panel.
- Type key: Depending on the construction/type of the battery, select: Wet or Agm/Spiral Cell.
- 7.2.5. Once the charging parameters have been set, press the START/STOP key to start charging the battery. When the START/STOP and CHARGING LEDs light up, the battery is being charged; the display will show the charging current and the voltage of the battery.
- 7.2.6. The CHARGING LED remains lit in phases "I" and "U0" whilst the battery is charging.
- 7.2.7. When the FULL LED switches on, it means that the battery is fully charged (100%) and the charger will switch to the maintenance phase, keeping the state of efficiency of the battery constantly monitored so that it is always at an optimal level of charge. In this charging phase, the appliance can be left connected to the battery for several months.
- 7.2.8. If you wish to end or interrupt the charging cycle, follow the end of charging instructions in section 7.5.

7.3. INTENTIONAL INTERRUPTION OF THE CHARGING CYCLE

If you want to interrupt the battery charging cycle, simply press the START/STOP key; the corresponding LED will switch off to show that the work cycle has ended. At this stage, it is recommended to disconnect the output leads from the battery terminals/ earthing point.

INTERRUPTION OF THE CHARGING CYCLE IN THE CASE OF A POWER SUPPLY CUT

In the case of a mains power supply cut, the charger saves the work cycle that it was performing in order to restore it automatically as soon as the power supply is restored.

This function is fundamental if the battery charger is used to charge batteries without the operator supervising the cycle; for example, during very long charging cycles (charge maintenance) or when charging overnight (charges for vehicles that need to be charged daily).

END OF CHARGING

Once the battery is charged, unplug the power supply lead of the charger from the mains supply.

Disconnect the output lead with the black clamp from the negative terminal (-) of the battery or from the vehicle's earthing point.

Disconnect the output lead with the red clamp from the positive terminal (+) of the battery. Store clamps properly on the charger.

STARTING A VEHICLE

Connect the charger to the vehicle as in section 7.1.1. to 7.1.4. above, and connect the charger to the mains supply as in 7.2.1. above. Select Start and also the correct battery type and battery capacity using the selection buttons on the control panel.

Press the Start button and the Start LED will flash for a while (analysis), and then will remain on (fast charging). Engine starting can now be attempted. Attempt to start the engine - the scrolling message START appears on the display - if the engine doesn't start within 5 seconds, stop cranking the engine and wait for 120 seconds before attempting again. A maximum of 5 cycles of starting/resting is OK, before a longer rest period is needed before attempting again. This is important as the charger needs a cooling down period. When the engine starts, switch off the charger and remove the clamps from the battery in the order as in section 7.5. above.

8. MAINTENANCE

- 8.1. When the battery charger is not being used, it must be stored in a dry place to protect it against humidity. Use a soft cloth to clean its outer casing.

Note: It is our policy to continually improve products and as such we reserve the right to alter data, specifications and component parts without prior notice.

Important: No Liability is accepted for incorrect use of this product.

Warranty: Guarantee is 12 months from purchase date, proof of which is required for any claim.



ENVIRONMENT PROTECTION

Recycle unwanted materials instead of disposing of them as waste. All tools, accessories and packaging should be sorted, taken to a recycling centre and disposed of in a manner which is compatible with the environment. When the product becomes completely unserviceable and requires disposal, drain any fluids (if applicable) into approved containers and dispose of the product and fluids according to local regulations.



WEEE REGULATIONS

Dispose of this product at the end of its working life in compliance with the EU Directive on Waste Electrical and Electronic Equipment (WEEE). When the product is no longer required, it must be disposed of in an environmentally protective way. Contact your local solid waste authority for recycling information.

Sealey Group, Kempson Way, Suffolk Business Park, Bury St Edmunds, Suffolk. IP32 7AR



01284 757500



01284 703534



sales@sealey.co.uk



www.sealey.co.uk