

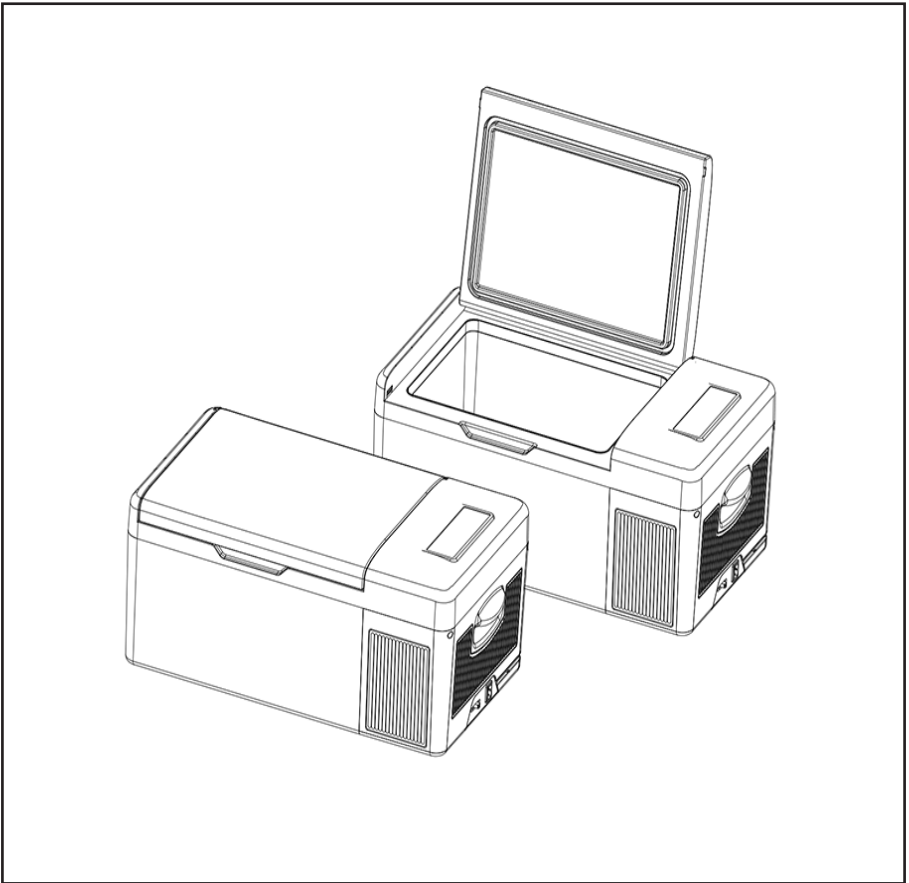

Dellonda 15L Portable Compressor Fridge Freezer/Cool Box, Car/Camping, 12/24V



Model No. DL12.v2

Thank you for purchasing a Dellonda product. Manufactured to a high standard, this product will, if used according to these instructions, and properly maintained, give you years of trouble free performance.

Important Information

Please read these instructions carefully and note any safe operational requirements, warnings & cautions. Use the product correctly and with care for the purpose for which it is intended. Failure to do so may cause damage and/or personal injury and will invalidate the warranty. Keep these instructions safe for future use.



Refer to
instruction
manual



Keep unit dry

Safety Instructions

• ELECTRICAL SAFETY

- **WARNING!** It is the user's responsibility to check the following:
- Check all electrical equipment and appliances to ensure that they are safe before using. Inspect power supply leads, plugs and all electrical connections for wear and damage. Electrical safety information: It is important that the following information is read and understood.
- Ensure that the insulation on all cables and on the appliance is safe before connecting it to the power supply.
- Regularly inspect power supply cables and plugs for wear or damage and check all connections to ensure that they are secure.
- **Important:** Ensure that the voltage rating on the appliance suits the power supply to be used and that the plug is fitted with the correct fuse - see fuse rating in these instructions.
- **DO NOT** pull or carry the appliance by the power cable.
- **DO NOT** pull the connector from the socket by the cable.
- **DO NOT** use worn or damaged cables, plugs or connectors.
- Ensure that any faulty item is repaired or replaced.
- Sealey recommend that any repairs are carried out by a qualified electrician / technical.
- Modern vehicles contain extensive electronic systems. You are required to check with the vehicle manufacturer, for any specific instructions regarding the use of this type of equipment on each vehicle. No liability will

- be accepted for damage/injury, where this product is not used in accordance with all instructions.

• GENERAL SAFETY

- Leave the unit to stand on a level surface for 6 hours after unpacking and before first switch-on.
- Keep the unit horizontal while it is running.
- Allow 10cm side and 20cm rear space for ventilation.
- Keep the unit dry and away from any heat source.

• SPECIFICATION

- Model no.:.....DL12.v2
- Capacity.....15L
- Temperature range.....-20°C to +20°C
- Refrigerant.....R600a
- Power rating.....45W
- Power Consumption:0.27kWh / 24hr
- Dimensions (w x d x h).....570 x 320 x 260mm
- Internal (w x d x h).....350 x 245 x 185mm

• OPERATION

- Plug the unit in and hold the On/Off button down for 3 seconds. Repeat to turn unit off.
- Press the +/- to adjust target temperature.
- Press the setting button to set up either **MAX** (fast cooling) or **ECO** (energy saving) mode.
- To set battery protection mode, with the unit turned on, press and hold the Setting button for 3 seconds.
- The default setting for battery protection is High (H). This value should be set when the unit is drawing power from the car battery.
- When connected to a portable power supply or other back-up battery, set mode to Medium (M) or Low (L) by cycling through the Setting button options.
- **NOTE:** If the battery power supply to the unit does not switch off when the vehicle's ignition is off, set battery mode to 'H' otherwise you may drain the vehicle battery.

• MAINTENANCE

- Remove the power plug from the unit when performing cleaning or maintenance.
- **DO NOT** use abrasive or chemical cleaning

materials on any surface of the unit.

- Wipe interior and exterior surfaces with a damp cloth and dry thoroughly with a clean dry cloth.
- For more soiled surfaces use a neutral detergent, wipe down with a clean damp cloth and dry thoroughly with a clean dry cloth.
- To defrost the unit, power it off, raise the lid, empty the contents and allow it to defrost. Carefully use a defrosting shovel to remove thawed ice and wipe the internals dry using a clean, dry cloth to absorb any remaining liquid.

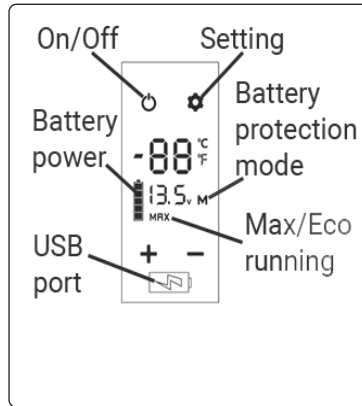

Troubleshooting

Display code	Possible cause and solution
F1	Low power protection. Change battery protection mode from 'H' to 'M' or from 'M' to 'L'
F2	Fan overload. Turn off and leave for 30 minutes.
F3	Compressor protection activated. Turn off and leave for 30 minutes.
F4	Compressor overloaded. Turn off and restart after 30 minutes.
F5	Compressor controller protection activated. Turn off and leave for 30 minutes.
F6	No parameter detected by controller. Restart unit.
F7/F8	Temperature sensor error. Turn off and restart unit.

If the issue is not resolved by carrying out the above procedures please contact Dellonda.

Environment Protection and Waste Protection and Electrical Equipment Regulations (WEEE)

Recycle unwanted packaging materials. When this product is no longer required, or has reached the end of its useful life, please dispose of it in an environmentally friendly way. Drain any fluids (if applicable) into approved containers, in accordance with local waste regulations. It is our policy to continually improve products and we reserve the right to alter data, specifications and parts without prior notice.

No liability is accepted for incorrect use of this product.

Guarantee is 12 months from purchase date, proof of which is required for any claim.

Dellonda Limited

Kempson Way, Suffolk Business Park, Bury St Edmunds, Suffolk. IP32 7AR

☎ 01284 757575 ✉ support@dellonda.co.uk 🌐 www.dellonda.co.uk