

baridi

Baridi Mini Tabletop Fridge/Freezer, 31L Capacity - White/ Black **230V ~ 50Hz**

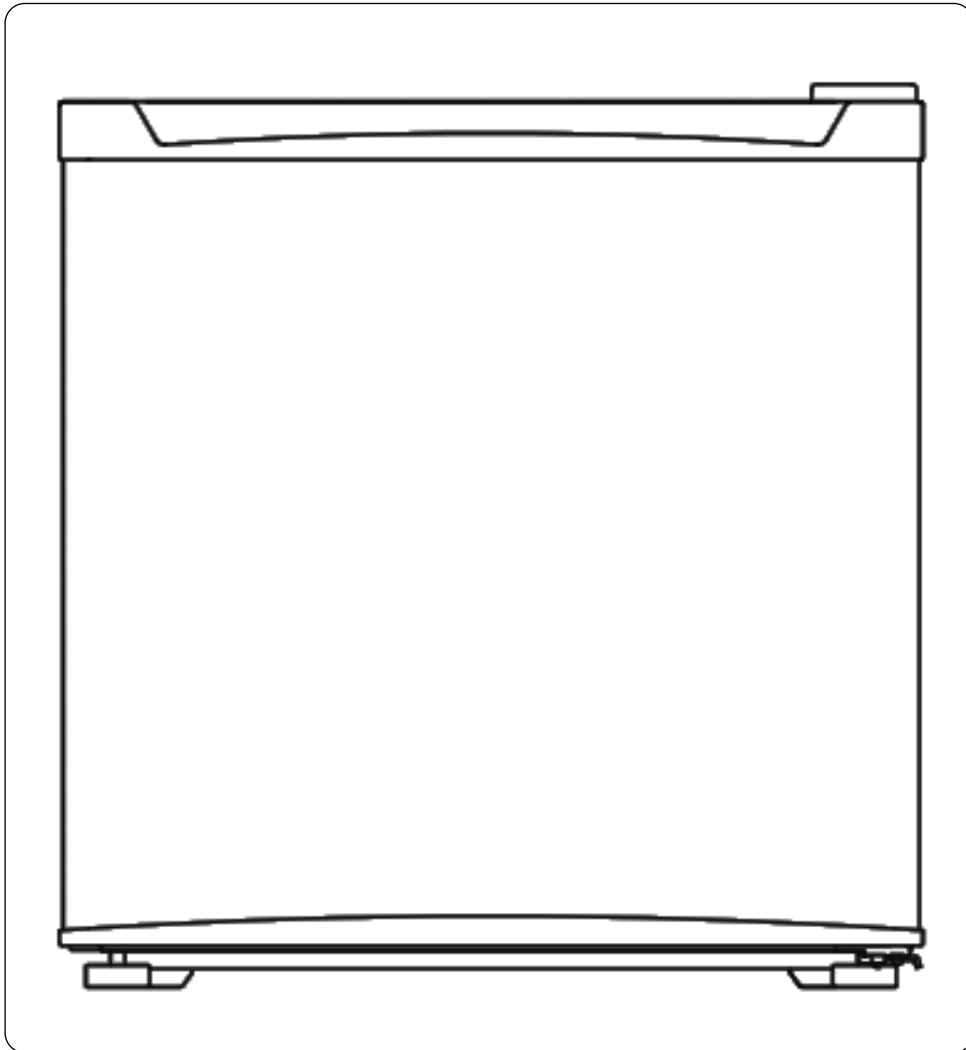

Model No: DH254, DH255

Thank you for purchasing a Baridi product from the Dellonda range. Manufactured to a high standard, this product will, if used according to these instructions, and properly maintained, give you years of trouble free performance.

Important Information

Please read these instructions carefully and note any safe operational requirements, warnings & cautions. Use the product correctly and with care for the purpose for which it is intended. Failure to do so may cause damage and/or personal injury and will invalidate the warranty. Keep these instructions safe for future use.



Refer to
instructions



Indoor use
only



WARNING!
Flammable
material

• ELECTRICAL SAFETY

- **WARNING!** It is the user's responsibility to check the following:
- Check all electrical equipment and appliances to ensure that they are safe before using.
- This product is not designed to be used with an inverter.
- Inspect power supply leads, plugs and all electrical connections for wear and damage.
- Ensure that the insulation on all cables and on the appliance is safe before connecting it to the power supply.
- **DO NOT** use worn or damaged cables, plugs or connectors.
- **DO NOT** use with an extension cord.
- Ensure that any faulty item is repaired or is replaced immediately by a qualified electrician.
- If the cable or plug is damaged during use, switch off the electricity supply and remove from use.
- If the supply cord is damaged, it must be replaced by the manufacturer, its service agent or similarly qualified persons in order to avoid a hazard
- Ensure that repairs are carried out by a qualified electrician.
- Dellonda recommend that an RCD (Residual Current Device) is used with all electrical products.
- Important: Ensure that the voltage rating on the appliance suits the power supply to be used and that the plug is fitted with the correct fuse.
- **DO NOT** pull or carry the appliance by the power cable.
- **DO NOT** pull the plug from the socket by the cable.

• GENERAL SAFETY

- Children from age 8 years and above, persons with reduced physical, sensory, or mental capabilities those with lack of experience and knowledge can use the appliance, if they have been given supervision or instruction concerning use of the appliance in a safe way to understand the hazards involved.
- Children aged from 3 to 8 years are allowed to load and unload refrigeration devices.
- Children shall **NOT** play with the appliance.
- Cleaning and user maintenance on the appliance shall not be made by children without supervision.
- The appliance shall be disconnected from its power source during service and when replacing parts and, if that the removal of the plug is foreseen, it shall be clearly indicated that the removal of the plug has to be such that an operator can check from any of the points to which he has access that the plug remains removed.
- This refrigeration appliance is not intended to be used as a built-in appliance.
- This refrigerant appliance is intended to be used at ambient temperatures ranging from 16°C to 38°C.
- **DO NOT** store explosive substances such as aerosol cans with a flammable propellant in this appliance.
- This appliance is intended to be used in household and similar applications such as:
 - – staff kitchen areas in shops, offices and other working environments
 - – farm houses and by clients in hotels, motels and other residential type environments
 - – bed and breakfast type environments
 - – catering and similar non-retail applications.
- To avoid contamination of food, please respect the following instructions:
 - - Opening the door for long periods can cause a significant increase of the temperature in the compartments of the appliance.
 - - Regularly clean surfaces that can come in contact with food and accessible drainage systems.
 - - Clean water tanks if they have not been used for 48 h; flush the water system connected to a water supply if water has not been drawn for 5 days.
- Store raw meat and fish in suitable containers in the refrigerator, so that it is not in contact with or drip onto other food.
- Two-star frozen-food compartments are suitable for storing pre-frozen food, storing or making ice-cream and making ice cubes.
- One-, two- and three-star compartments are not suitable for the freezing of fresh food.
- If the refrigerating appliance is left empty for long periods, switch off, defrost, clean, dry, and leave the door open to prevent mould developing within the appliance.
- **WARNING!** When positioning the appliance, ensure the supply cord is not trapped or damaged.
- **WARNING! DO NOT** locate multiple portable socket-outlets or portable power supplies at the rear of the appliance.
- The appliance shall not be exposed to rain.
- **COMPRESSION TYPE APPLIANCES WHICH USE FLAMMABLE REFRIGERANTS**
- **WARNING!** Keep ventilation openings, in the appliance enclosure or in the built-in structure, clear of obstruction.
- **WARNING! DO NOT** use mechanical devices or other means to accelerate the defrosting process, other than those recommended by the manufacturer.
- **WARNING! DO NOT** damage the refrigerant circuit.
- **WARNING! DO NOT** use electrical appliances inside the food storage compartments of the appliance, unless they are of the type recommended by the manufacturer.
- **WARNING!** When positioning the appliance, ensure the supply cord is not trapped or damaged.
- **WARNING! DO NOT** locate multiple portable socket-outlets or portable power supplies at the rear of the appliance.

• LOCKS

- If your Refrigerator is fitted with a lock, keep the key out of reach and not in the vicinity of the appliance to prevent children being entrapped. When disposing of an old Refrigerator, break off any old locks or latches as a safeguard.

• **FREON-FREE**

• The freon-free refrigerant (R600a) and the foaming insulation material (cyclopentane) that is environmentally friendly are used for the refrigerator, causing no damage to the ozone layer and having a very small impact on the global warming. R600a is flammable, and sealed in a refrigeration system, without leakage during normal use. But, in case of refrigerant leakage due to the refrigerant circuit being damaged, be sure to keep the appliance away from open flames and open the windows for ventilation as quickly as possible.

• **PRODUCT FEATURES**

NO	DESCRIPTION
1	Shelf
2	Thermostat control
3	Water tray
4	Adjustable Feet

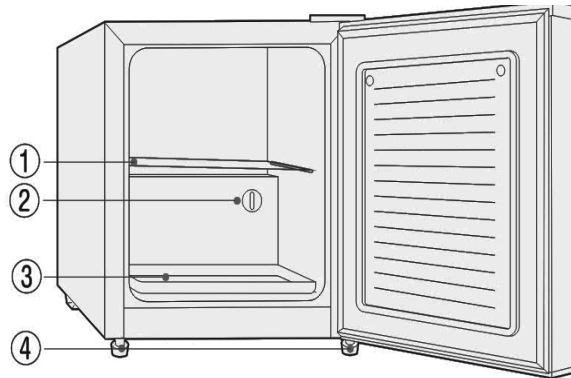

• **DOOR REVERSAL INSTRUCTIONS**

1. Make sure that your refrigerator is unplugged.
2. Remove the hinge cover and upper hinge from the top right side of the cabinet. Remove the screw hole cover from the top left side of the cabinet.

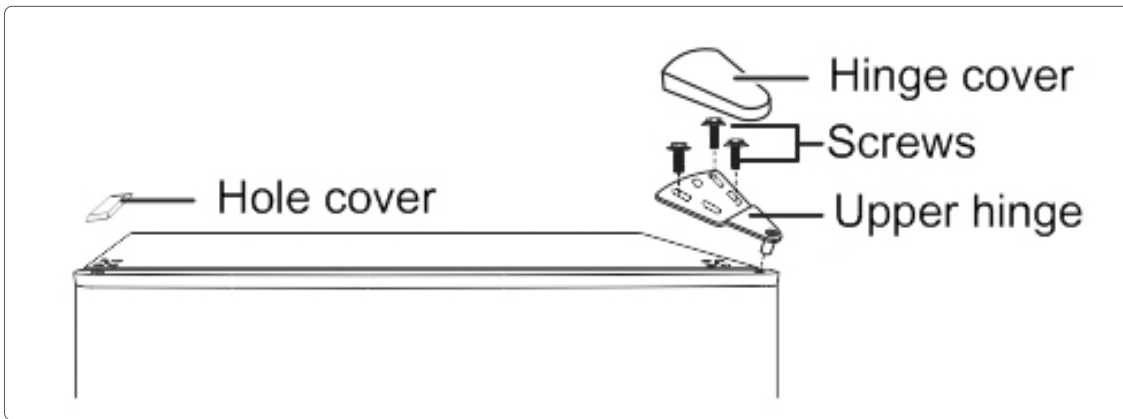

3. Remove the freezer compartment door from the cabinet.
4. Remove the screws that secure the lower hinge to the right side of the cabinet, then remove the hinge. Then remove the adjustable foot.

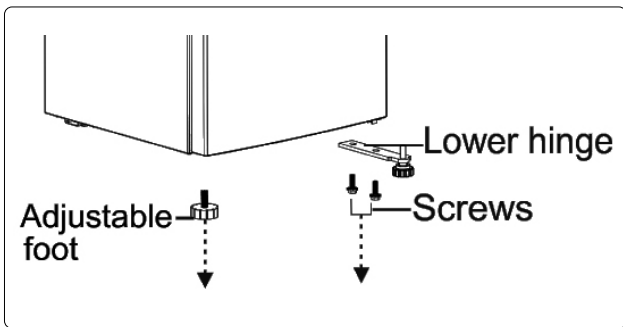

5. Remove the adjustable foot on the lower hinge shaft, and remove the washer and nut.

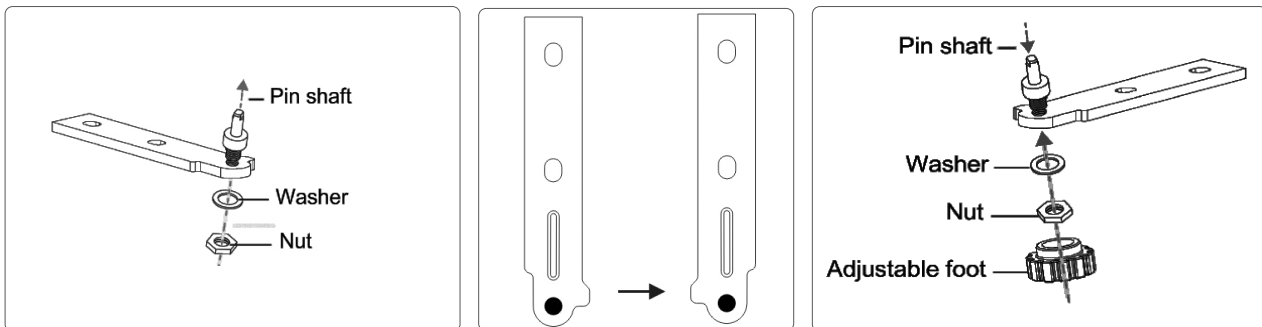

6. Turn the lower hinge by 180°
7. Install the washer and nut into the hole on the pin shaft, and then install the adjustable foot.
8. Install the lower hinge on the left side of the cabinet. Install the adjustable foot at the right.
9. Remove the screw that secures the door stop from the bottom right of the freezer compartment door, then remove the door stop and install to the bottom left side.

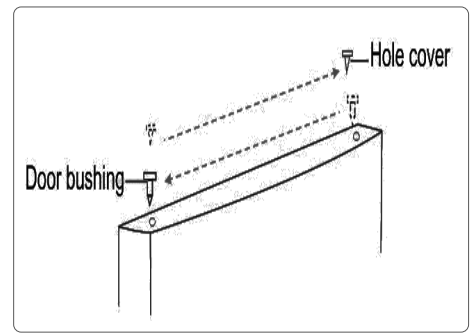
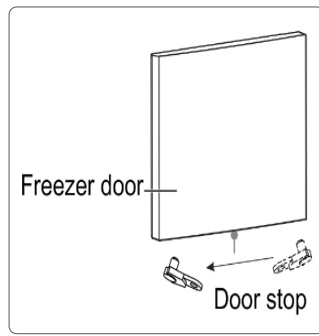
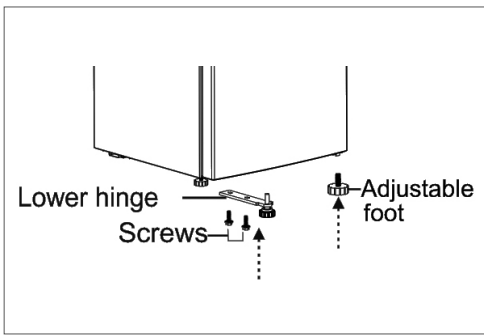

10. Install the freezer compartment door.

11. Move the door bushing from the top right side of the freezer door to the top left side of the door. And move the left hole cover to the right side.

12. Secure the upper hinge to the top left side of the cabinet with the three screws you removed previously. Before you tighten the upper hinge screws, make sure that the top of the door is level with the cabinet and that the rubber gasket makes a good seal.

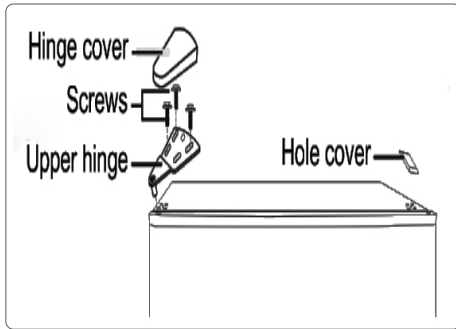

- **INSTALLATION INSTRUCTIONS**
- **VENTILATION CONDITION**

The position you select for the refrigerator installation should be well-ventilated and has less hot air. Do not locate the refrigerator near a heat source such as cooker, and avoid it from direct sunlight, thus guaranteeing the refrigeration effect while saving energy consumption. Do not locate the refrigerator in the damp place, so as to prevent the refrigerator from rusting and leaking electricity. The result of the refrigerant charge amount of the refrigerator being divided by the total space of the room in which the refrigerator is installed shall be less than $8g/m^3$.

NOTE: The amount of refrigerant charged for the refrigerator can be found on the nameplate.

- **HEAT DISSIPATION SPACE**

When working, the refrigerator gives off heat to the surroundings. Therefore, at least 30mm of free space should be spared at the top side, more than 100mm on both sides, and above 50mm at the back side of the refrigerator.

Dimensions in mm:

W	D	H	A	B	C (°)	E	F
474	447	496	800	875	130±5	50	100

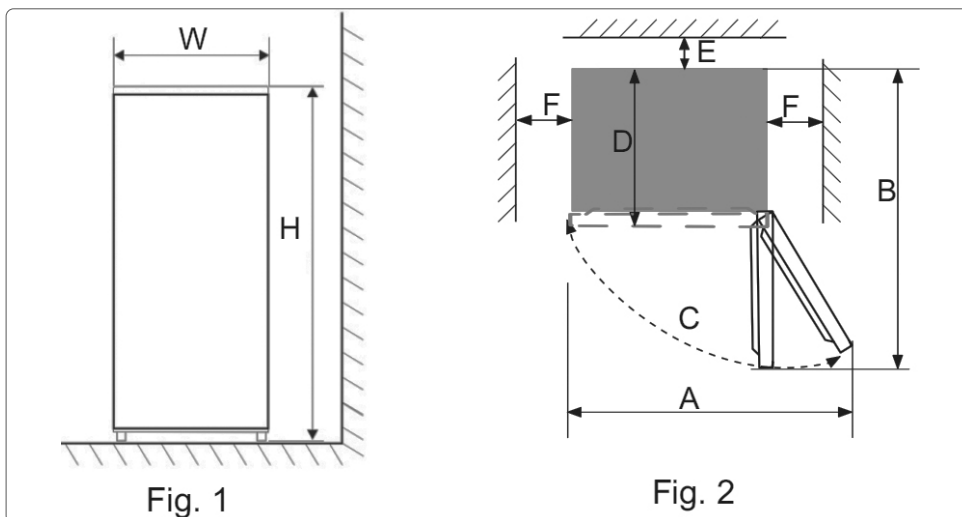

Note: Figure 1, Figure 2 only illustrate the space demand of the product.

LEVEL GROUND

Place the refrigerator on the solid and flat ground (floor) to keep it stable, or else, it will give rise to vibration and noise. When the refrigerator is placed on such flooring materials as carpet, straw mat, polyvinyl chloride, the solid backing plates should be applied underneath the refrigerator, (not supplied) so as to prevent colour change due to heat dissipation.

NOTE: Unobstructed ventilation shall be maintained around the appliance or in an embedded structure.

PREPARATIONS FOR USE

1. STANDING TIME

After the refrigerator is properly installed and well cleaned, do not switch it on immediately. Make sure to energise the refrigerator after more than 1 hour's standing, so as to ensure its normal operation.

2. CLEANING

Confirm the accessory parts inside the refrigerator and wipe the inside with a soft cloth.

3. POWER-ON

Insert the plug into the solid socket to start the compressor. After 1 hour, open the refrigerator door, if the temperature inside the refrigerator compartment drops obviously, it indicates the refrigeration system is working normally.

4. STORAGE OF FOOD

After the refrigerator runs for a period of time, the internal temperature of the refrigerator will be automatically controlled according to the user's temperature setting. After the refrigerator is fully cooled, put in foods, which usually need 3 hours to be fully cooled. In summer, when the temperature is high, it takes more than 4 hours for the foods to be fully cooled. Open the refrigerator door as little as possible before the internal temperature cools down.

- **NOTE:** If the refrigerator is installed where there is high humidity, make sure to check whether the ground wire and leakage circuit breaker are normal. If vibration noises are produced due to the refrigerator contacting the wall or if the wall gets blackened by air convection around the compressor, move the refrigerator away from the wall. Setting up the refrigerator may cause jamming noise or image chaos to mobile phones, fixed-line telephones, radio receivers, and televisions surrounding it, so try to keep the refrigerator as far away as possible in such case.
 - **OPERATION**
 - **TEMPERATURE SELECTION**
 - **Temperature control**
 - The temperature of the appliance can be adjusted by turning the thermostat knob.
 - Freezer temperature range: MIN about -15 °C MAX about -24 °C.
 - Refrigerator temperature range: about 0 to 10 °C. The thermostat dial can be set between 1 to 5
 - The temperature decreases as the setting number goes up.
 - Internal temperature of the appliance can vary based on ambient temperature, the quantity of items stored and how frequently the door is opened.
 - **LOCATION**
 - **DO NOT** place your refrigerator/freezer near a heat source, e.g. cooker, boiler or radiator. Avoid direct sunlight in out-buildings or sun lounges.
 - **LEVELLING**
 - Make sure to level your refrigerator/freezer using the front levelling feet. If not level, the refrigerator/freezer door gasket sealing performance will be affected, or even it may lead to the operating failure of your refrigerator/freezer.
 - After locating the refrigerator/freezer in position, wait for 4 hours before using it, so as to allow the refrigerant to settle.
 - **DO NOT** cover or block the vents or grilles of your appliance.
 - **APPLIANCE STORAGE**
 - If the appliance will not be used for several months, turn it off first, and then unplug the plug from the wall outlet.
 - Take out all foods.
 - Clean and dry the interior thoroughly. To prevent odour and mould growth, leave the door ajar: block it open or have the door removed if necessary.
 - Keep the cleaned appliance in a dry, ventilated place and away from the heat source, place the appliance smoothly, and do not place heavy objects on top of it.
 - **NOTE:** When using the fridge mode, you need to pour away the defrosting water in the drip tray inside the cabinet timely after a period of use, in order to prevent the defrosting water from overflowing to the floor.
 - **WARNING!**
 - The information regarding the temperature range of the appliance is provided on the rating plate.
 - The internal temperature could be affected by such factors as the location of refrigerating appliance, ambient temperature, and frequency of door open, etc/ The setting of the temperature control thermostat might have to be varied to allow for these factors.
 - Effervescent drinks should not be stored in the freezer compartment or the low-temperature compartment, and some products such as water ices should not be consumed too cold.
 - **FOOD STORAGE LOCATIONS**
 - **DO NOT** put too much weight inside the refrigerator. Keep enough space between foods; if too close, the cold air flow will be blocked, thus affecting the refrigeration effect. **DO NOT** store excessive quantities or overweight foods, to avoid the shelf from being crushed
 - When storing the foods, keep a distance away from the inner wall; and do not place the water-rich foods too close to the refrigerator rear wall, so they don't get frozen on the inner wall.
 - **COMPARTMENT**
 - Long-term storage of foods: The freezer compartment, where the temperature is generally controlled below -18 °C, is suitable for the preservation of foods for a long term, but the shelf life indicated on the food packages should be followed.
 - Allow hot foods to cool down to room temperature before putting them in the freezer compartment.
 - **DO NOT** put a glass container with liquid or canned liquids that are sealed into the freezer compartment to avoid bursting due to volume expansion after the liquid gets frozen.
 - Divide the food into appropriately small portions
 - Pack the food up before freezing it, and the packing bag used should be dry, in case the packing bags are frozen together. Foods should be packed or covered with a suitable materials as are firm, tasteless, impervious to air and water, non-toxic and pollution-free, to avoid cross-contamination and transfer of odour.
- TIPS FOR SHOPPING FOR FROZEN FOODS**
1. When you are buying frozen food, look at the Storage Guidelines on the packaging. You will be able to store each item of frozen food for the period shown against the star rating. This is usually the period stated as "Best to use them before date", found on the front of the packaging.
 2. Check the temperature of the frozen food cabinet in the shop where you buy the frozen foods.
 3. Make sure the frozen food package is in perfect condition.
 4. Always buy frozen products last on your shopping trip or visit to the supermarket.
 5. Try to keep frozen food together whilst shopping and on the journey home, as this will help to keep the food cooler.
6. Don't buy frozen food unless you can freeze it straight away. Special insulated bags can be bought from most supermarkets and hardware shops. These keep the frozen foods cold longer.
 7. For some foods, thawing before cooking is unnecessary. Vegetables and pasta can be added directly to boiling water or steam cooked. Frozen sauces and soups can be put into a saucepan and heated gently until thawed.
 8. Use quality food and handle it as little as possible. When foods are frozen in small quantities, it will take less time for them to freeze up and thaw.

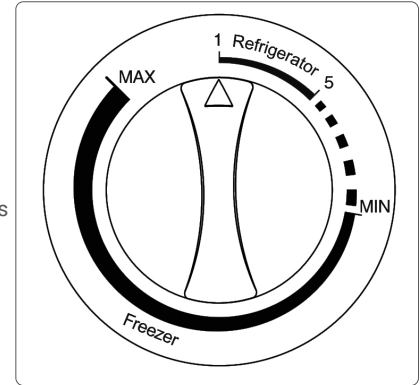

9. Estimate the number of food to be frozen. When freezing large amounts of fresh food, adjust the temperature control knob to the low mode, with the freezer temperature lowered. So, foods can be frozen up in a fast manner, with the food freshness retained.

• **ICE TRAY**

Place the ice-making box in the upper position of the freezer compartment, so that it ices up as soon as possible.

• **CLEANING**

After a period of use, a thin layer of frost will be formed on the freezer compartment inner wall (or evaporator) surface, which may affect the refrigeration effect if exceeding 5mm in thickness. In such case, you need to gently scrape the frost off using an ice scraper rather than the metal or sharp hardware. Frosts need to be cleared off every 3 months or so, and if the normal use of drawers and normal access of foods are affected by frosting, make sure to remove the frost in a timely manner. Follow the following steps to remove frost:

1. Take out the frozen foods, shut off the mains power supply, open the refrigerator door, and gently remove the frost from the inner wall with an ice scraper. To speed up the thawing process, place a bowl of hot water inside the refrigerator/freezer, and when the solid ice frost become loose, use an ice scraper to scrape them off and then take them out.
2. After defrosting, clean the refrigerator/freezer inside, and switch on the power supply.

• **TROUBLESHOOTING**

If the product is not working properly, please refer to the following table. If the problem cannot be resolved, please contact a Dellonda authorised service centre.

PROBLEM	POSSIBLE CAUSE / SOLUTION
The refrigerator doesn't work.	Check the power supply is connected and free from damage.
The refrigerator is noisy.	Ensure the refrigerator is placed on flat, stable ground, away from other objects or walls. Use the adjustable feet as necessary to level the appliance.
The internal temperature is too high.	Select the appropriate temperature. Ensure the door is closed and there is enough ventilation space around the appliance. DO NOT leave the door open for long periods.

• **DISPOSAL**

• **Dispose according to local regulations in force.**



Environment Protection, Waste Electrical and Waste Electronic Equipment Regulations (WEEE)



Recycle unwanted packaging materials. When this product is no longer required, or has reached the end of its useful life, please dispose of in an environmentally friendly way. Drain any fluids (if applicable) into approved containers, in accordance with local waste regulations. It is our policy to continually improve products and we reserve the right to alter data, specifications and parts without prior notice. No liability is accepted for incorrect

Dellonda Limited, Sole UK Distributor of Baridi

Kempson Way, Suffolk Business Park, Bury St Edmunds, Suffolk. IP32 7AR



01284 757575



support@dellonda.co.uk



www.dellonda.co.uk