

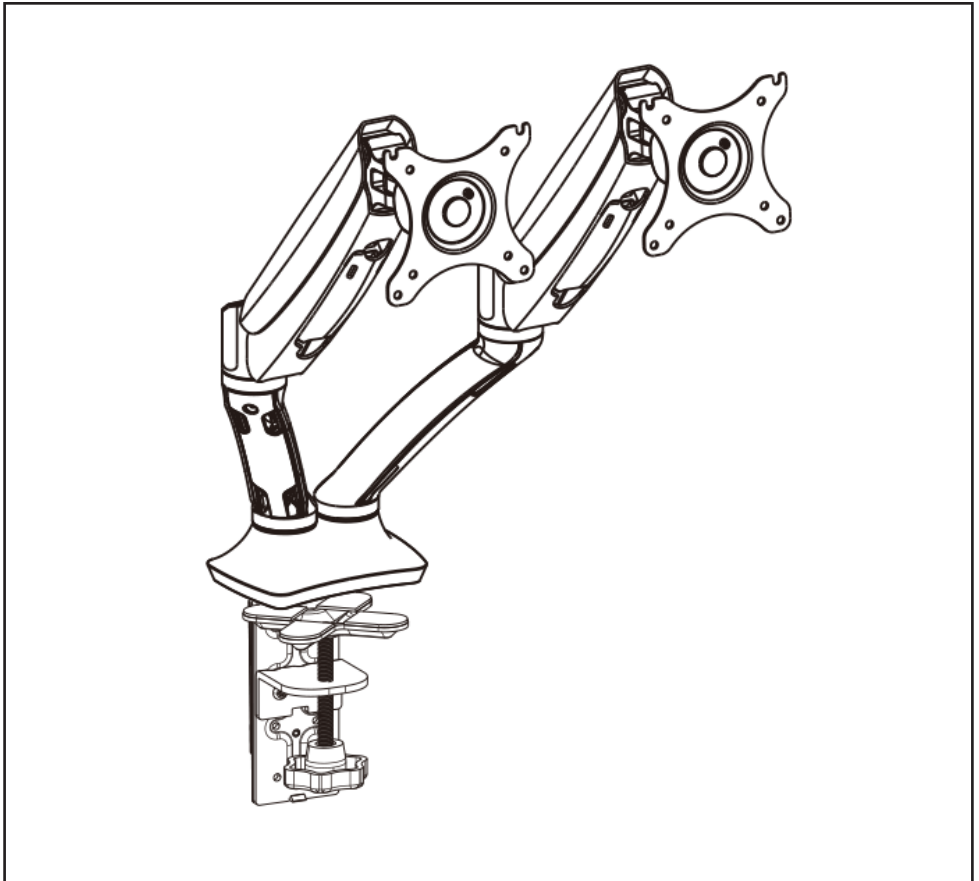

---

## Dellonda Adjustable Dual Monitor Arms, 360° Rotation 9kg Capacity for 10-27" Screens



### Model No. DH25

Thank you for purchasing a Dellonda product. Manufactured to a high standard, this product will, if used according to these instructions, and properly maintained, give you years of trouble free performance.

## Important Information

Please read these instructions carefully. Note the safe operational requirements, warnings & cautions. Use the product correctly and with care for the purpose for which it is intended. Failure to do so may cause damage and/or personal injury and will invalidate the warranty. Keep these instructions safe for future use.

## Contents



M4X12MM  
A (8PCS)



M5X12MM  
B (8PCS)



M6X12MM  
C (3PCS)



M6X10MM  
D (2PCS)



φ 6.5X φ 13X1.8  
E (16PCS)



4X4 Allen key  
F (1PCS)



5X5 Allen key  
G (1PCS)

①	Bottom support 1	1PCS	1
②	Screw	1PCS	
③	Washer	1PCS	2
④	Butterfly knob	1PCS	
⑤	Bottom support 2	1PCS	3
⑥	Knob	1PCS	
⑦	Cable cover 1	1PCS	
⑧	Nylon ties	10PCS	
⑨	Anti-slip rubber 1	1PCS	
⑩	Anti-slip rubber 2	4PCS	
⑪	Anti-slip rubber 3	1PCS	
⑫	Cable cover 2	2PCS	
⑬	M6 box wrench	1PCS	

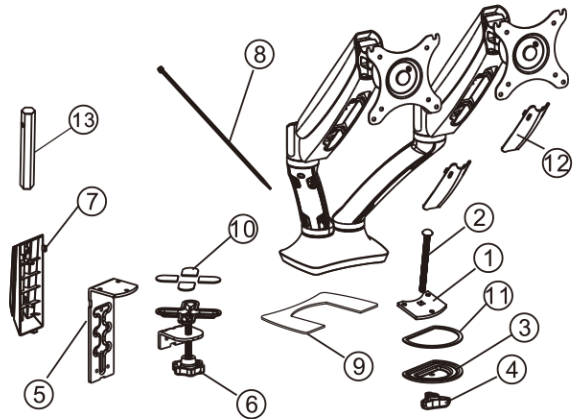

## About the Product

Adjustable double monitor arms create a more ergonomic workspace. Monitor arms easily adjust using gas spring system. Features 360° rotation enabling you to convert your display orientation from landscape to portrait. Features cable management system ensuring a tidy desk.

## Safety Instructions

- This product contains small items that could be a choking hazard if swallowed. Keep these items away from small children.
- Ensure instructions are read and completely understood before attempting installation. If unsure contact a professional installer for assistance.
- The desk/mounting surface must be capable of supporting the combined weight of the mount and the display. Otherwise the structure must be reinforced.
- Never exceed the max. load of 9kg.
- Safety gear (safety shoes) and proper tools must be used.
- A minimum of 2 people are required for this installation. Failure to use safety equipment can result in property damage, serious injury or death.
- Check fixings for tightness every 2 months.
- Note: this product is intended for indoor use only.
- **WARNING!** This product contains high pressure gas spring parts. Do not put into a fire, high temperature or disassemble it.
- To ensure the sealing performance of the gas spring the upper arm (with the spring) should be adjusted properly each month.

## Preparation Before Assembly

- Make sure the **VESA** holes 100 x 100 mm or 75 x 75 mm in the monitor (fig.1).
- Remove the original fixed base of monitor.

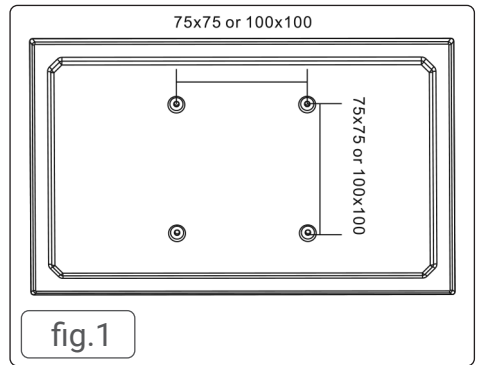

## Installation With Clamp (Fig.2)

- For table thickness: 20-100mm.
- Select right holes according to the thickness of the desk.

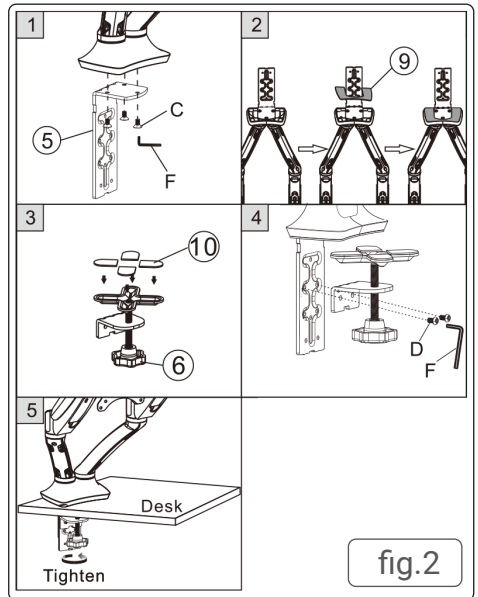

## Installation With Bolt (Fig.3)

- For table thickness: 25-90mm

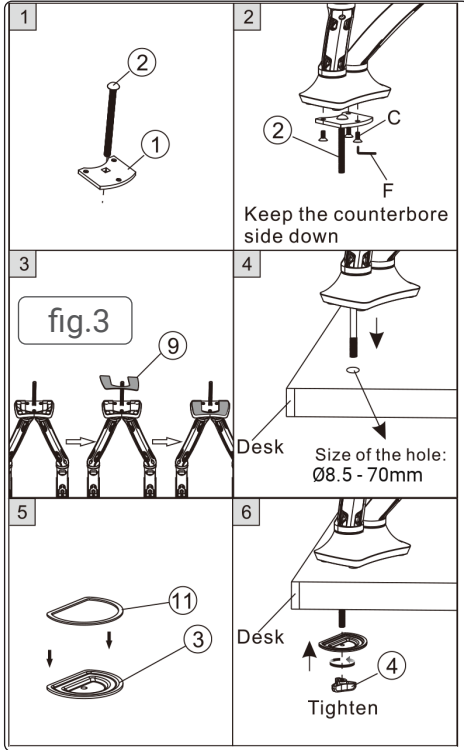

- Use the correct size washers (fig.4.E) for your monitor.

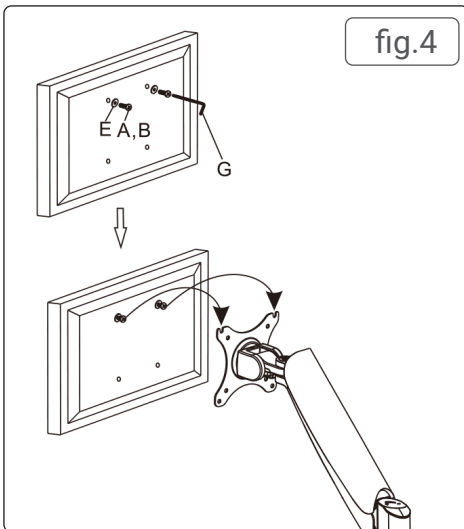

## Attaching The Monitor (Fig.5)

- To adjust the monitor use the supplied 5x5 Allen key (G)
- Adjust the monitor height after installing. If the monitor keeps dropping, use the supplied 5x5 Allen key to adjust the screw on the arm in "-" direction.
- If the monitor cannot be lowered use the supplied 5x5 Allen key to adjust the screw on the arm in "+" direction.
- Make the resistance of the arm equal to the weight of the monitor.

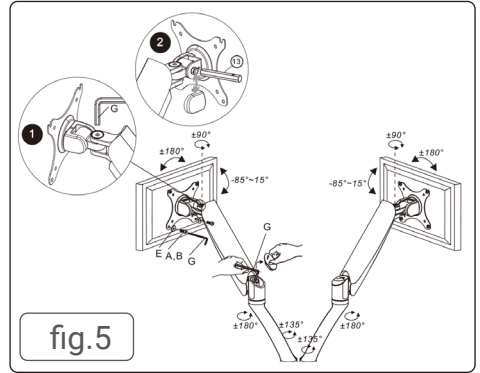

## Attaching And Using The Inbuilt Cord Management

- Fig.7.12 Remove cover from top arm by gently pulling until it comes away.
- Fig.6.8 use cable tie to secure cables in the arm.
- To remove the cable tidy from the lower arm remove the screw (fig.7).
- If using the clamp to attach to the desktop. Use the plastic cover/cable tidy to cover the clamp and manage the cables (fig.7.7).

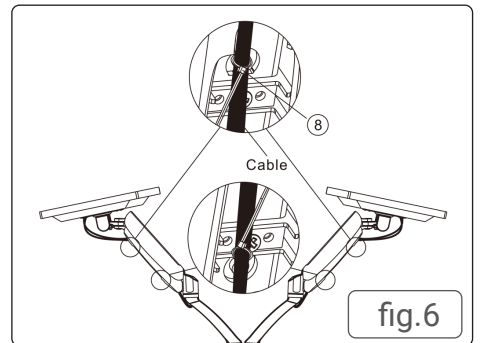

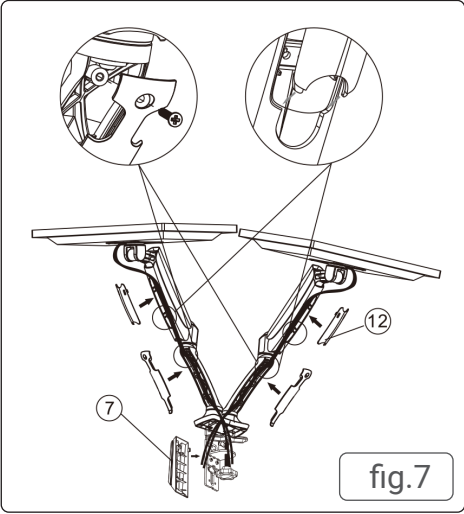

fig.7

## Specifications

Supported VESA:	75 x 75, 100 x 100mm
Supported Screen Size:	10-27"
Load Capacity:	2-9kg
Tilt Range:	-85 - 15°
Installation:	Clamp & Grommet



### Environment Protection and Waste Protection and Electrical Equipment Regulations (WEEE)

Recycle unwanted packaging materials. When this product is no longer required, or has reached the end of its useful life, please dispose of it in an environmentally friendly way. Drain any fluids (if applicable) into approved containers, in accordance with local waste regulations. Under the Waste Batteries and Accumulators Regulations 2009, Jack Sealey would like to inform the user that this product contains one or more batteries. It is our policy to continually improve products and we reserve the right to alter data, specifications and parts without prior notice.



No liability is accepted for incorrect use of this product. Guarantee is 12 months from purchase date, proof of which is required for any claim.

## Dellonda Limited

Kempson Way, Suffolk Business Park, Bury St Edmunds, Suffolk. IP32 7AR



01284 757575



support@dellonda.co.uk



www.dellonda.co.uk