

Thank you for purchasing a Sealey product. Manufactured to a high standard this product will, if used according to these instructions and properly maintained, give you years of trouble free performance.

⚠ IMPORTANT: PLEASE READ THESE INSTRUCTIONS CAREFULLY. NOTE THE SAFE OPERATIONAL REQUIREMENTS, WARNINGS AND CAUTIONS. USE THE PRODUCT CORRECTLY AND WITH CARE FOR THE PURPOSE FOR WHICH IT IS INTENDED. FAILURE TO DO SO MAY CAUSE DAMAGE AND/OR PERSONAL INJURY AND WILL INVALIDATE THE WARRANTY. PLEASE KEEP INSTRUCTIONS SAFE FOR FUTURE USE.

1. SAFETY INSTRUCTIONS

- ✓ Before use inspect the drum handler for damage and worn components.
- ✓ If in any doubt do not use and have inspected/repaired by an authorised service agent.
- ✓ Only use the drum handler on firm, level, unobstructed surfaces which are capable of supporting the handler and drum.
- ✗ **Do not** overload the drum handler - maximum capacity is **360kg**.
- ✗ **Do not** ride or allow others to ride on the drum handler.
- ✗ **Do not** use on tarmac/adam. The drum handler must only be used on a concrete surface.
- ✗ **Do not** overload.
- ✓ Replace or repair damaged parts. *Use only recommended parts. Unauthorised parts may be dangerous and will invalidate the warranty.*
- ✓ Use a qualified person to lubricate and maintain the drum handler.
- ☐ **WARNING!** Failure to comply with these instructions may result in loss of load, damage to drum handler or other property and/or personal injury.

2. INTRODUCTION & SPECIFICATION

Ideal for manoeuvring, relocating and draining fully loaded drums. Lever handle raises drums in stages with fingertip-operated locks. Adjustable for reach/leverage and clamp height. Clips on both sides hold drum secure in vertical or horizontal positions. Drum can be manually adjusted and held at any angle or, if contents need mixing, can be turned end-over-end. Handler is fitted with two, smooth-rolling, heavy-duty wheels and one castor. Suitable for 205ltr drums.



Specification	
Drum Size205 litres
Weight50kg
Lifting Weight360Kg

Figure 1 Reference			
Item	Description	Item	Description
1	Chassis	10	Location Lever
2	Mast	11	Lifting Arm
3	Supporting Hoop	12	Hanger Plate
4	Handle	13	Adjustment Hole
5	Location Pin	14	Pawl
6	Fastening Lever	15	Hinged Hoop
7	Chain	16	Adjustment Hole
8	Wheel	17	Hook
9	Caster		

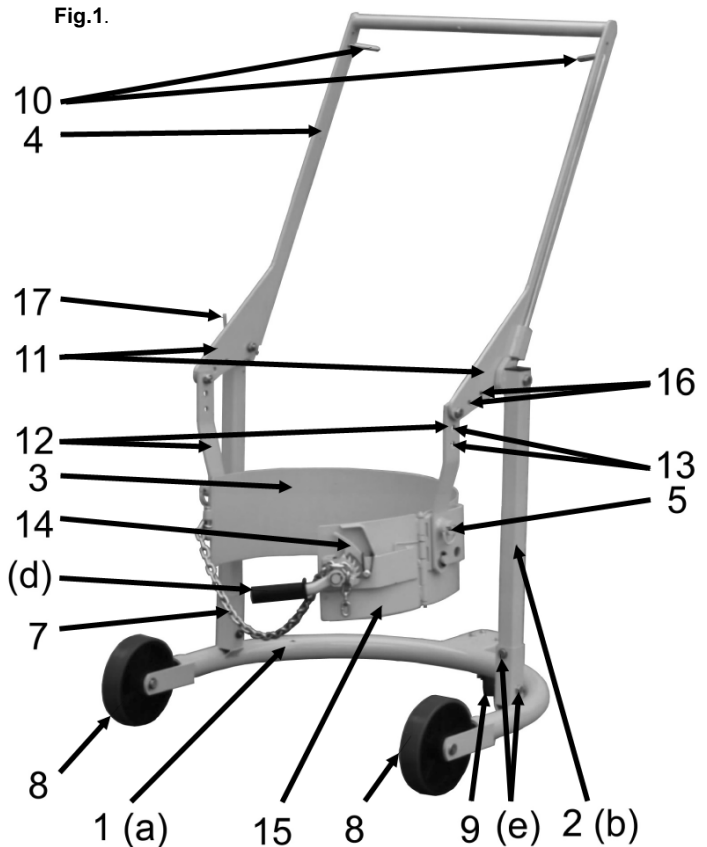

3. ASSEMBLY

- 3.1 Remove the sub-assemblies from packaging in following order.
- a Chassis (Fig.1.1).
 - b Mast (Fig.1.2).
 - c Supporting Hoop (Fig.1.3).
 - d Handle (Fig.1.4).
 - e Washers, nuts and clamp collars.
- 3.1 Assemble mast (b) on chassis (a) with the screws, washers and nuts provided (e).
- 3.1.1 Bolt this assembly to the lifting arms (Fig.1.11).
- 3.1.2 Attach the supporting hoop assembly (Fig.1.3) with hangers (Fig.1.12) to the handle (Fig.1.4) and secure with bolts provided.

Refer to parts diagram for additional guidance.

4. OPERATION

4.1 Clamping Drum.

- 4.1.1 The opening section of the hoop (Fig.1.15) is sprung loaded to remain open when not clamped to a drum.
- 4.1.2 Position the Drum Handler so that the supporting hoop (Fig. 1. 3) encompasses the drum to be lifted.
- 4.1.3 Pull the location levers (Fig.1.10) to release the handle (Fig.1.4) to locate the supporting hoop in the middle of the drum.
- 4.1.4 Release the location levers to lock the handle in this position.
- 4.1.5 Turn the fastening lever (Fig.1.6) so the teeth are pointing upwards, take the slack up on the chain and place it in the groove (Fig.3) on the fastening lever ensuring that it is fully located as in Fig.3.1.
- 4.1.6 Pull the fastening lever sharply clockwise until the chain is tight and the ratchet pawl has locked the ratchet as in Fig.4.
- 4.1.7 Check that the drum is now securely held in place. If the chain is not tight repeat procedure 4.1.5 to 4.1.6 but take more slack out of the chain. The drum is now ready to be lifted.

4.2 Lifting Drum.

- 4.2.1 Pull the handle (Fig.1.4) downwards, this will lift the drum.
- 4.2.2 When the drum is at the required height, slowly release the handle and the location levers will automatically lock the handle in place.

4.3 Transportation.

- 4.3.1 Push or pull the drum handler using the handle to the required destination. Apply pressure left or right to steer the handler.

CAUTION! Ensure that there are no obstructions in your path, make sure the floor surface is suitable to take the weight of the fully laden drum handler.

4.4 Lower & Release Drum.

- 4.4.1 To lower the drum, apply downward pressure to the handle (Fig.1.4).
- 4.4.2 Pull the two location levers (Fig.1.10) at the same time.
- 4.4.3 This will release the handle and drum which may now be lowered to the ground, when the drum reaches a firm surface, release the location levers.
- 4.4.4 Turn the fastening lever clockwise slightly to disengage the ratchet pawl.
- 4.4.5 Release the fastening lever and remove the chain and hang it on the hook (Fig.1.17).
- 4.4.6 Pull the drum handler away from the drum.

4.5 Rotate the Drum.

- 4.5.1 The drum handler can rotate the drum from vertical to horizontal position.
- 4.5.2 To turn the drum from vertical to horizontal disengage pins (Fig.1.5) and turn through 90° to lock them in the disengaged position and then turn the drum through 90° to the horizontal position.
- 4.5.3 Rotate the pins again until they engage with the supporting hoop to secure the drum in the horizontal position.

Note! Before rotating drum make sure drum has been lifted sufficiently high enough allowing it to turn without interference from the ground.

4.6 Adjustment.

- 4.6.1 If the supporting hoop is too high to hold the middle of the drum while the handle is at its highest point or the drum cannot be lifted to the required height when the handle has reached its lowest point it will be necessary to adjust the height of the supporting hoop.
- 4.6.2 Choose another hole (Fig.1.13/16) on the lifting arm (Fig.1.11) and/or the hanger plates (Fig.1.12) remove the hanger plate bolts from the original position and relocate them in the new position ensuring that the same hole is chosen for each side.

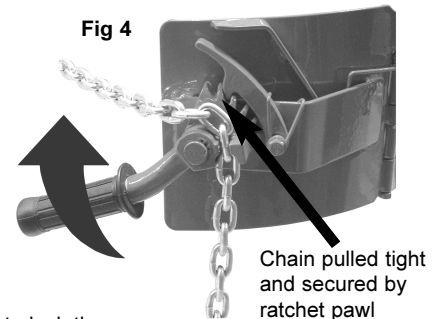
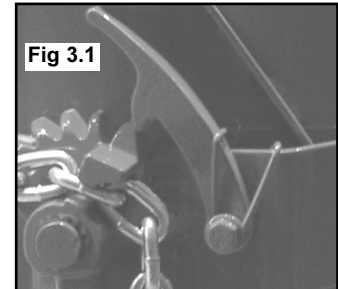
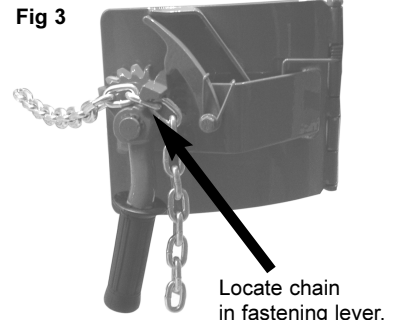

5. MAINTENANCE

- 5.1 Regularly check the drum handler chassis and wheels for rigidity. Ensure that the rear castor is firmly secured to the chassis.
- 5.2 Regularly check the pawl and ratchet for wear. Replace when necessary.
- 5.3 Regularly check the drum handlers connecting components such as retaining pins, nuts and washers for lubrication and/or wear.
- 5.4 Keep handle free from grease and oil to prevent accidents.

6. DECLARATION OF CONFORMITY

Declaration of Conformity MOBILE DRUM HANDLER 250ltr Model DH02 <small>98/37/EC Machinery Directive</small>		We, the sole importer into the UK, declare that the product listed below is in conformity with the following standards and directives. The construction file for this product is held by the Manufacturer and may be inspected, by a national authority, upon request to Jack Sealey Ltd. Signed by Mark Sweetman 21 September 2005 For Jack Sealey Ltd. Sole importer into the UK of Sealey Power Products.
---	--	---

NOTE: It is our policy to continually improve products and as such we reserve the right to alter data, specifications and component parts without prior notice.

IMPORTANT: No liability is accepted for incorrect use of this product.

WARRANTY: Guarantee is 12 months from purchase date, proof of which will be required for any claim.

INFORMATION: For a copy of our catalogue and latest promotions call us on 01284 757525 and leave your full name, address and postcode.

	Sole UK Distributor Sealey Group, Bury St. Edmunds, Suffolk.	01284 757500 01284 703534	www.sealey.co.uk sales@sealey.co.uk
--	--	--	--