

INSTRUCTIONS FOR:
FLOOR STANDING METAL FOLDER
 Model No: **DF910**

Thank you for purchasing a Sealey product. Manufactured to a high standard this product will, if used according to these instructions and properly maintained, give you years of trouble free performance.

IMPORTANT: PLEASE READ THESE INSTRUCTIONS CAREFULLY. NOTE THE SAFE OPERATIONAL REQUIREMENTS, WARNINGS AND CAUTIONS. USE THIS PRODUCT CORRECTLY AND WITH CARE FOR THE PURPOSE FOR WHICH IT IS INTENDED. FAILURE TO DO SO MAY CAUSE DAMAGE OR PERSONAL INJURY, AND WILL INVALIDATE THE WARRANTY. PLEASE KEEP INSTRUCTIONS SAFE FOR FUTURE USE.

The DF910 floor standing sheet metal folder is intended for folding and bending up to 22 gauge sheet metal (max 910mm capacity) only. Do not use any other material with this product.

Specifications

- | | |
|---|--|
| Maximum sheet size 910mm | Maximum dia of steel rod 2mm |
| Maximum sheet thickness 22 gauge (0.7mm). | Maximum width of 14 gauge (2mm) steel sheet strip - 100mm |
| Unit weight 28kg | Note: When bending 14 gauge (2mm) strip or 2mm diameter steel rod, they must be placed close to one of the set screws. |

1. SAFETY INSTRUCTIONS

- 3 Wear approved safety goggles when operating the DF910. Your local Sealey dealer offers a complete range of safety equipment.
- 3 Use the tool only for its intended purpose.
- 3 Check all items of the DF910 regularly for damaged parts. Do not use if any of its components are broken, worn or damaged.
- 3 Use original Sealey spare parts and accessories. Use of non-recommended spare parts may be dangerous and will invalidate warranty.
- 7 DO NOT operate this tool while under the influence of drugs, alcohol or other impairing medication.
 allow unqualified persons to operate the metal folder. Keep children away from the tool.

2. ASSEMBLY

Unpack the unit and check that all parts are included and not damaged. Should you experience a problem contact your supplier immediately.

Content: 1x Main frame. 2 x Cross bars. 1 x Folding plate. 1 x Foot stand.
 1 x Bag of nuts/Bolts consisting of: 2 x Set screws (L-shaped), 6 x Bolts, 6x Nuts, 6 x Washers.

- 2.1. Lay the folder main frame (fig 1. A) on the floor with the top folding plate (fig1.1) uppermost.
- 2.2. Attach the foot stand (3) to the legs of the main frame (A) using the nuts, bolts and washers supplied. The foot stand cross bar (3) must be facing uppermost when the main frame is on the floor.
- 2.3. Ensure the support brackets (4) are secured to the outside of the main frame legs and the outside of the foot stand.
- 2.4. Fully tighten all nuts and bolts.
- 2.5. Attach the top plate using the L-shaped set screws (2).
- 2.6. Raise assembled folder to upright position so the foot stand cross bar (3) and lift top folding plate (1) are to the front of the unit.

3. USE AND OPERATION

- 3.1. Screw the two adjusting nuts (B) down to ensure the folding plates (C) are parallel. This may require further adjustment from time to time.
- 3.2. Insert a test piece of sheet metal in the folder.
- 3.3. Secure the metal between the folding lips by tightening the two clamps, whilst ensuring there is even pressure on both ends.
- 3.4. Place your foot on the base cross bar (3).
- 3.5. Raise the top folding plate (1) to create the fold. From this test, you will be able to determine how and where the fold appears.
- 3.6. When satisfied with the test results, proceed with the actual workpiece.
- 3.7. Repeat the above steps 3.2 - 3.5 for each new workpiece.

DF910 PART LIST		
No	Description	Pcs
1	Top folding plate	1
2	Set screws	2
3	Foot stand ("C" shape)	1
4	Support brackets	2

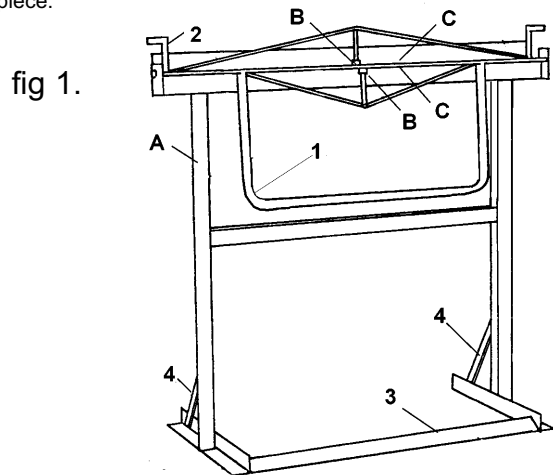

MODIFICATIONS:

It is our policy to continually improve products and as such we reserve the right to alter data, specifications and component parts without prior notice.

IMPORTANT: No responsibility is accepted for incorrect use of this product.

WARRANTY: Guarantee is 12 months from purchase date. Proof of purchase will be required for any claim.

INFORMATION: Please call us for a copy of our latest catalogue

DF910 - 260598