



VACUUM DRILL DUST EXTRACTOR 3.7V

MODEL NO: **DDE01.V3**

Thank you for purchasing a Sealey product. Manufactured to a high standard, this product will, if used according to these instructions, and properly maintained, give you years of trouble free performance.

IMPORTANT: PLEASE READ THESE INSTRUCTIONS CAREFULLY. NOTE THE SAFE OPERATIONAL REQUIREMENTS, WARNINGS & CAUTIONS. USE THE PRODUCT CORRECTLY AND WITH CARE FOR THE PURPOSE FOR WHICH IT IS INTENDED. FAILURE TO DO SO MAY CAUSE DAMAGE AND/OR PERSONAL INJURY AND WILL INVALIDATE THE WARRANTY. KEEP THESE INSTRUCTIONS SAFE FOR FUTURE USE.



Refer to instructions



Wear eye protection



Wear a mask



Warning Laser

1. SAFETY

1.1. GENERAL SAFETY

- × **DO NOT** use this device in direct sunlight.
- × **DO NOT** allow the dust extractor to get wet.
- × **DO NOT** allow unqualified persons or children to operate this device.

1.2. LASER SAFETY The DDE01.V3 utilises a Class II laser that emits a low level of visible radiation (i.e. a wavelength of 650 nanometres) which is safe for the skin but not inherently safe for the eyes. The Class II emission limit is set at the maximum level for which eye protection is normally afforded by natural aversion responses to bright light. Accidental eye exposure is therefore normally safe, although the natural aversion response can be overridden by deliberately staring into the beam, and can also be influenced by the use of alcohol or drugs.

- × **DO NOT** direct the laser beam at any person's (or animal's) eyes as eye damage could result.
- × **DO NOT** operate the laser level when you are tired or under the influence of alcohol, drugs or intoxicating medication. Be aware that reflections of the laser beam from mirrors or other shiny surfaces can be as hazardous as direct eye exposure.
- × **DO NOT** expose your eyes to the laser beam. Laser can cause harm to eyes.
- ☐ **WARNING!** This product is not water-proof. Please **DO NOT** expose it to water as this may cause electric shock, short circuit or fire.
- ✓ Use goggles when operating.
- ☐ **WARNING!** Plastic parts may be damaged by detergents and solvents such as gasoline, Carbon tetrachloride, chlorinated cleaning solvents, ammonia and detergents containing ammonia.
- × **DO NOT** disassemble or modify this product.

2. INTRODUCTION

Vacuum holds unit to the wall for easy drilling. Suitable for drill bits up to Ø20mm. Features a horizontal and vertical spirit level. Laser light on the bottom for accurate positioning of holes, for example in a sequence or a square. Removable dust collection pod for easy emptying. Rechargeable lithium-ion powered battery with USB type C cable.

3. SPECIFICATION

Model No:	DDE01.V3
Maximum Drilling Diameter:	Ø20mm
Nett Weight:	0.274kg

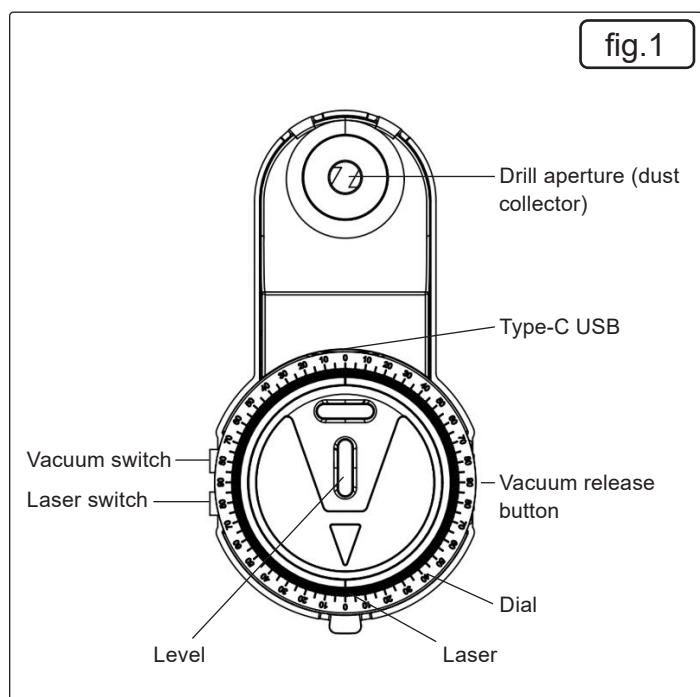
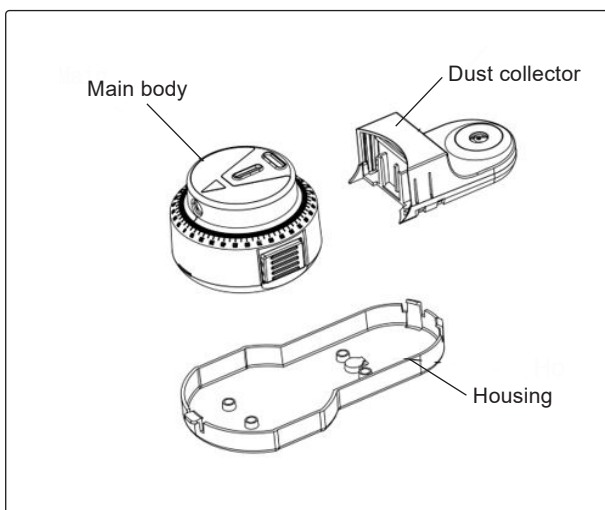

4. OPERATION

4.1. HOW TO SEPARATE HOUSING

4.1.1. Press clips to separate the housing. (Fig.2).

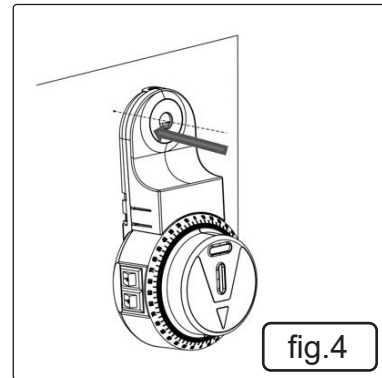
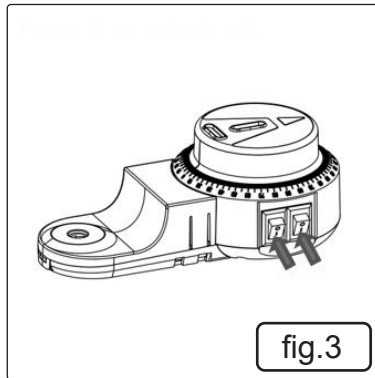
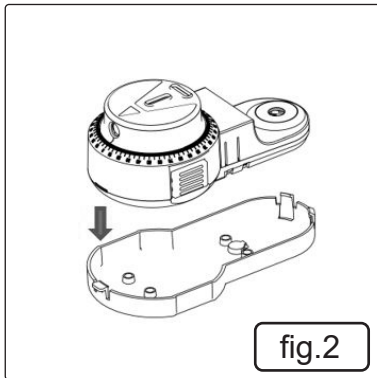

4.2. SWITCHING THE VACUUM DRILL DUST EXTRACTOR ON/OFF

4.2.1. Press I to switch on vacuum or laser. Press 0 to switch off. (fig.3).

4.3. DRILLING A HOLE

4.3.1. Mark position of hole that you want to drill. If drilling more than one hole in succession the laser guides can be used to line up with your markings. (fig.4).

4.3.2. There is a small gap in the bristles on-top of the device that allow you to see your prepared markings. Line up your mark with this hole. You can also use the lasers and spirit levels to help with this.

4.3.3. When happy with your placement turn on the vacuum. The device will now be stuck to the wall. The vacuum can be released using the button on the side of the body. (fig.3).

4.4. USING THE LASER MARKER

4.4.1. Press the on/off switch to turn on/off laser.

4.4.2. The laser can be adjusted 360° degrees in 1° degree steps.

4.4.3. Turn the dial to achieve the desired angle. (fig.5).

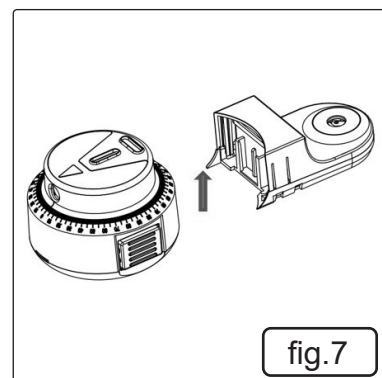
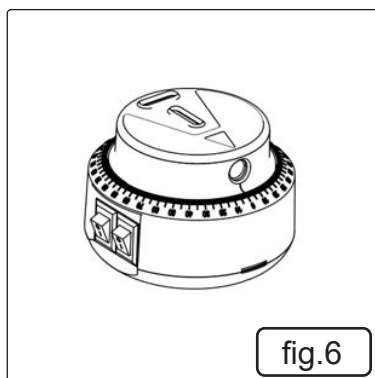
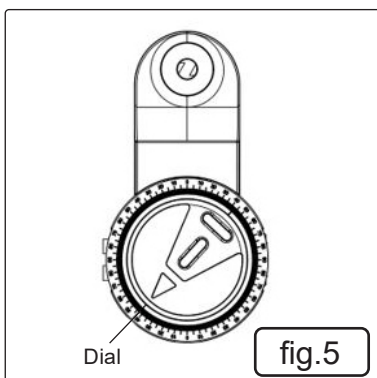

4.5. RELEASING THE VACCUM

4.5.1. Switch off vacuum using the vacuum release button on the side of the vacuum drill dust extractor.

4.5.2. Remove vacuum drill dust extractor from surface.

4.6. EMPTYING THE COLLECTOR

4.6.1. The device can be slid apart leaving you with two pieces. The dust collection pod and the suction device. (fig.7).

4.6.2. The dust collection pod comes apart by gently pressing the tabs on the sides. Once apart the dust should be safely disposed of.

NOTE: The dust is collected via gravity and not suction.

4.7. CHARGING THE UNIT

4.7.1. Separate the dust pod to expose the charging port on the end face of the unit (fig.8).

4.7.2. Connect the USB charge cable to the charge socket on the body. (fig.9).

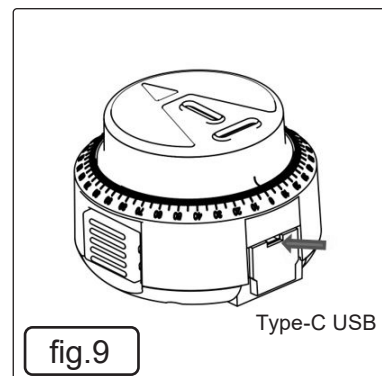
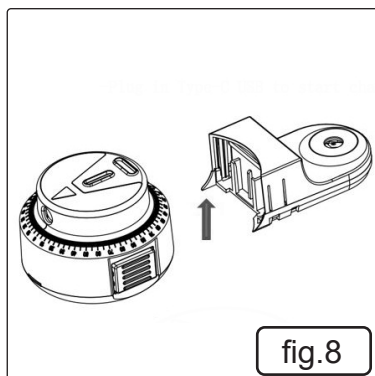
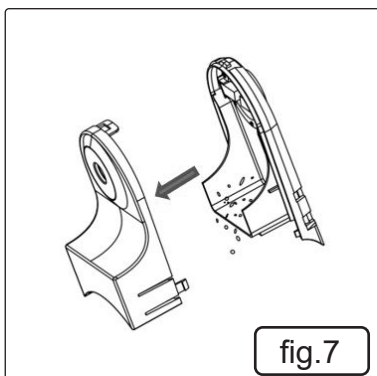

6. MAINTENANCE

- 6.1. Dispose of waste according to local regulations.
- 6.2. Wipe unit clean with a damp cloth.

7. TROUBLESHOOTING

ERROR	REASON	SOLUTION
Laser or vacuum not working	Power not on	Check position of switch
	Battery exhausted	Recharge



BATTERY REMOVAL

Under the Waste Batteries and Accumulators Regulations 2009, Jack Sealey Ltd are required to inform potential purchasers of products containing batteries (as defined within these regulations), that they are registered with Valpak's registered compliance scheme. Jack Sealey Ltd's Batteries Producer Registration Number (BPRN) is BPRN00705.



ENVIRONMENT PROTECTION

Recycle unwanted materials instead of disposing of them as waste. All tools, accessories and packaging should be sorted, taken to a recycling centre and disposed of in a manner which is compatible with the environment. When the product becomes completely unserviceable and requires disposal, drain any fluids (if applicable) into approved containers and dispose of the product and fluids according to local regulations.



WEEE REGULATIONS

Dispose of this product at the end of its working life in compliance with the EU Directive on Waste Electrical and Electronic Equipment (WEEE). When the product is no longer required, it must be disposed of in an environmentally protective way. Contact your local solid waste authority for recycling information.



BATTERY REMOVAL: SEE SECTION 4.3

Under the Waste Batteries and Accumulators Regulations 2009, Jack Sealey Ltd are required to inform potential purchasers of products containing batteries (as defined within these regulations), that they are registered with Valpak's registered compliance scheme. Jack Sealey Ltd Batteries Producer Registration Number (BPRN) is BPRN00705.

Note: It is our policy to continually improve products and as such we reserve the right to alter data, specifications and component parts without prior notice. Please note that other versions of this product are available. If you require documentation for alternative versions, please email or call our technical team on technical@sealey.co.uk or 01284 757505.

Important: No Liability is accepted for incorrect use of this product.

Warranty: Guarantee is 12 months from purchase date, proof of which is required for any claim.

Sealey Group, Kempson Way, Suffolk Business Park, Bury St Edmunds, Suffolk. IP32 7AR



01284 757500



01284 703534



sales@sealey.co.uk



www.sealey.co.uk