

5. PARTS LIST

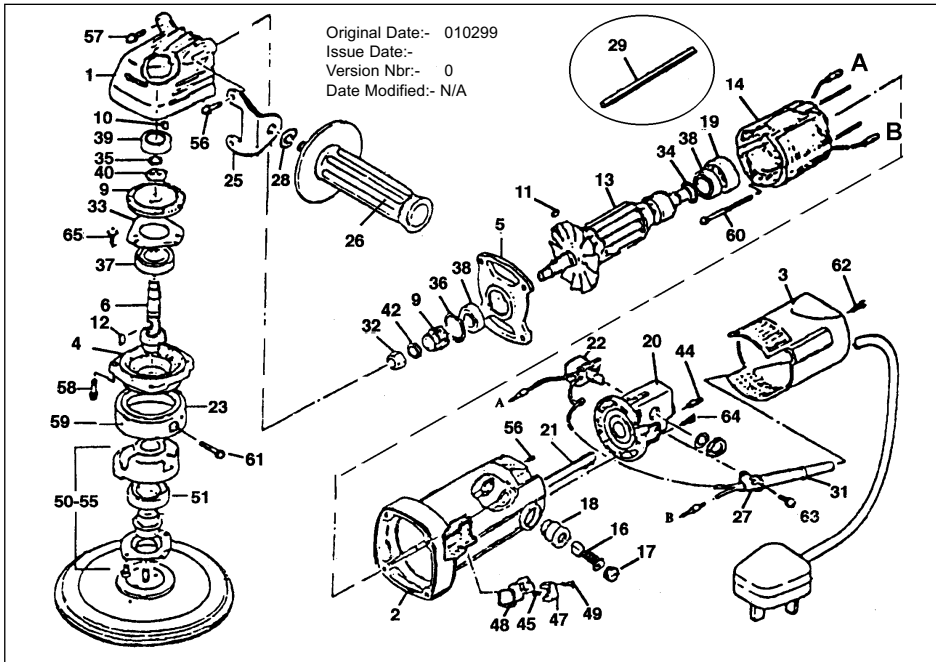

ITEM NO	PART NO	DESCRIPTION	ITEM NO	PART NO	DESCRIPTION	ITEM NO	PART NO	DESCRIPTION
1	102/153001	Head	23	102/153023	Balancer Ring	48	102/103048	Switch Button, Spring & Lock
2	102/103002	Body	25	102/107025	Grip Fitting Plate	49	102/103049	Screw, M5 x 8
3	102/103003	End Case	26	102/122026	Grip	50-55	102/153050	Balancer Set
4	102/153004	Head Cap	27	102/100027	Band	51	B/6202-RS	Bearing
5	102/105005	Centre Bracket	28	102/120050	Spring Washer, M10	56	102/100056	Screw, M4 x 6
6	102/153006	Gear Shaft	29	102/153029	Bar Wrench	57	102/100057	Screw, M5 x 20
9	102/153009	Gear Set	31	102/100031	Anti-kink Sleeve	58	102/153058	Screw, M4 x 14
10	102/100019	Rubber, Ø 4	32	102/100032	Lock Nut	59	102/100059	Screw, M4 x 6
11	102/100011	Woodruff Key, Ø 10mm	33	102/100033	Bearing Fitting Plate	60	102/100060	Screw, M4 x 60
12	102/100012	Woodruff Key, Ø 13mm	34	102/153034	Dust Plate	61	102/153061	Screw, M6 x 25
13	102/153013	Armature, 240 Volt	35	102/100035	Stop Ring, S-10	62	102/100062	Screw, M4 x 12
14	102/153014	Field Coil, 240 Volt	36	102/100036	Stop Ring, R-22	63	102/100063	Screw, M4 x 12
16	102/100016	Carbon Brush	37	B/6200-2RS	Bearing	64	102/100064	Screw, M4 x 16
17	102/100017	Brush Holder Cap	38	B/608-2RS	Bearing	65	102/100065	Screw, M4 x 10
18	102/100018	Brush Holder	39	B/B/608Z	Bearing	66	102/106057	Screw, M5 x 25
19	102/103019	Bearing Cap	40	102/105041	Wave Washer	102/DFS-BRACKET		DFS Dust Hose Mounting Bracket
20	102/103020	Switch Fitting Plate	42	102/100042	Spring Washer			
21	102/103021	Switch Lever	44	102/105044	Switch Spring			
22	102/153022	Switch, On/Off	46	102/100045	Connector Set			

Declaration of Conformity We, the sole importer into the UK, declare that the products listed here are in conformity with the following EEC standards and directives. The construction files for these products are held by the Manufacturer and may be inspected on request by contacting Jack Sealey Ltd

DUAL ACTION SANDER Models: DAS150 & DAS150/DFS
73/23/EEC Low Voltage Directive (S.I. 1994/3260).
89/336/EEC EMC Directive (S.I. 1992/2372) and amendments.
89/392/EEC Machinery Directive (S.I. 1992/3073) and amendments



Signed by Mark Sweetman
1st March 1999

For Jack Sealey Ltd. Sole importer into the UK of Sealey Power Tools

NOTE: It is our policy to continually improve products and as such we reserve the right to alter data, specifications and component parts without prior notice. **IMPORTANT:** No liability is accepted for incorrect use of this equipment. **WARRANTY:** Guarantee is 12 months from purchase date. proof of which will be required for any claim. **INFORMATION:** Call us for a copy of our latest catalogue on 01284 757525 and leave your full name and address including your postcode.



Sole UK Distributor, Sealey Group, Bury St. Edmunds, Suffolk.



01284 757500



01284 703534

E-mail: sales@sealey.co.uk



INSTRUCTIONS FOR DUAL ACTION SANDER

Models: DAS150, & DAS150/DFS

Thank you for purchasing a Sealey Product. Manufactured to a high standard this product will, if used according to these instructions and properly maintained, give you years of trouble free performance.



IMPORTANT: PLEASE READ INSTRUCTIONS CAREFULLY. NOTE THE SAFE OPERATIONAL REQUIREMENTS, WARNINGS AND CAUTIONS. USE THIS PRODUCT CORRECTLY AND WITH CARE FOR THE PURPOSE FOR WHICH IT IS INTENDED. FAILURE TO DO SO MAY CAUSE DAMAGE OR PERSONAL INJURY, AND WILL INVALIDATE THE WARRANTY. PLEASE KEEP INSTRUCTIONS SAFE FOR FUTURE USE.

1. SAFETY INSTRUCTIONS

- 1.1. **ELECTRICAL SAFETY. ⚠ WARNING!** It is the user's responsibility to read, understand and comply as follows. **You must** check all electrical equipment and appliances to ensure they are safe before using. **You must** inspect power supply leads, plugs and all electrical connections for wear and damage. **You must** ensure the risk of electric shock is minimised by the installation of appropriate safety devices. An RCCB (Residual Current Circuit Breaker) should be incorporated in the main distribution board. We also recommend that an RCD (Residual Current Device) is used with all electrical products. It is particularly important to use an RCD together with portable products that are plugged into an electrical supply not protected by an RCCB. If in doubt consult a professional electrician. You may obtain a Residual Current Device by contacting your Sealey dealer. **You must** also read and understand the following instructions concerning electrical safety.
 - 1.1.1. The Electricity At Work Act 1989 requires all portable electrical appliances, if used on a business premises, to be tested by a qualified Electrician at least once a year by using a Portable Appliance Tester (PAT).
 - 1.1.2. The Health & Safety at Work Act 1974 makes owners of electrical appliances responsible for the safe condition of the appliance, and the safety of the appliance operator. If in doubt about electrical safety, contact a qualified electrician.
 - 1.1.3. Ensure the insulation on all cables and the product itself is safe before connecting to the mains power supply. See 1.1.1. & 1.1.2. above and use a Portable Appliance Tester (PAT).
 - 1.1.4. Ensure that cables are always protected against short circuit and overload.
 - 1.1.5. Regularly inspect power supply, leads, plugs and all electrical connections for wear and damage, especially power connections, to ensure that none are loose.
 - 1.1.6. Important: Ensure the voltage marked on the product is the same as the electrical power supply to be used, and check that plugs are fitted with the correct capacity fuse. A 13Amp plug may require a fuse smaller than 13Amps for certain products (subject to 1.1.10. below) see fuse rating below.
 - 1.1.7. DO NOT pull or carry the powered appliance by its power supply lead. Products such as welders must not be pulled or carried by their output cables.
 - 1.1.8. DO NOT pull power plugs from sockets by the power cable.
 - 1.1.9. DO NOT use worn or damaged leads, plugs or connections. Immediately replace or have repaired by a qualified Electrician. A U.K. 3 pin plug with ASTA/BS approval is fitted. In case of damage, cut off and fit a new plug according to the following instructions (discard old plug safely). (UK only - see diagram at right). Ensure the unit is correctly earthed via a three-pin plug.
 - a) Connect the green/yellow earth wire to the earth terminal 'E'.
 - b) Connect the brown live wire to live terminal 'L'.
 - c) Connect the blue neutral wire to the neutral terminal 'N'.
 After wiring, check there are no bare wires, that all wires have been correctly connected and that the wire restraint is tight. Double insulated products are often fitted with live (BROWN) and neutral (BLUE) wires only. Double insulated products are always marked with this symbol . Check you model carefully to see which type of product you have. To re-wire, a double insulated item, connect the brown and blue wires as indicated above. DO NOT connect brown or blue to the earth terminal.
 - 1.1.10. Cable extension reels. When a cable extension reel is used it should be fully unwound before connection. A cable reel with an RCD fitted is recommended since any product which is plugged into the cable reel will be protected. The section of the cable on the cable reel is important. We recommend that at least 1.5mm² section cable but to be absolutely sure that the capacity of the cable reel is suitable for this product and for others that may be used in the other output sockets, we recommend the use of 2.5mm² section cable.

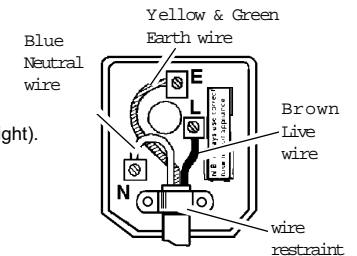

FUSE RATING
THIS PRODUCT MUST BE
FITTED WITH A:
3 Amp FUSE

1.2. Safety Instructions Cont:

- p **WARNING!** Ensure health & safety, local authority, & general workshop practice regulations are adhered to when using this equipment.
- p **WARNING!** Disconnect from mains power before changing accessories, servicing or maintenance.
- 3 Maintain the sander in good condition (use an authorised service agent).
- 3 Replace or repair damaged parts. Use genuine parts only. Non authorised parts may be dangerous and will invalidate the warranty.
- 3 Use sander in an adequate working area for its function, keep area clean, tidy and free from unrelated materials. Ensure there is adequate lighting.
- 3 Before use check abrasive pad condition. If worn or damaged replace immediately.
- p **WARNING!** Always wear approved eye or face protection when operating the sander.
- 3 If dust is generated, use face, dust, or respiratory protection in accordance with COSHH regulations.
- 3 Depending on task, sander noise level may exceed 85dB in which case wear safety ear defenders.
- 3 Remove ill fitting clothing, ties, watches, rings, other loose jewellery, and contain and/ or tie back long hair.
- 3 Wear appropriate protective clothing and keep hands and body clear of the sanders working parts.
- 3 Maintain correct balance and footing. Ensure the floor is not slippery and wear non slip shoes.
- 3 Keep children and unauthorised persons away from the working area.
- 3 Check moving parts alignment on a regular basis.
- 3 Always use the sander with the side handle grip securely assembled.
- 3 Ensure the workpiece is correctly secured before operating the sander. Never hold workpiece by hand, and check the workpiece to ensure there are no protruding nails, screws, stones, etc.
- 3 Avoid unintentional starting.
- 3 For DAS150/DFS switch off the sander before you switch off the dust collection system.
- 7 DO NOT force the sander to achieve a task it was not designed to perform.
- 7 DO NOT operate sander if any parts are damaged or missing. This may cause failure or possible injury.
- p **WARNING!** DO NOT sand any materials containing asbestos.
- 7 DO NOT carry the sander by the electrical cable, or dust hose of DAS150/DFS.
- 7 DO NOT connect DAS150/DFS to a standard vacuum cleaner to extract dust as damage may result.
- 7 DO NOT get the sander wet or use in damp or wet locations.
- 7 DO NOT use sander with water, the sander is for dry use only.
- 7 DO NOT place attachments close to your face and do not point at other persons or animals.
- 7 DO NOT operate sander if you are tired, under the influence of alcohol, drugs or intoxicating medication.
- 7 DO NOT use where there is flammable liquids, solids or gases such as paint solvents, including waste wiping or cleaning rags etc.
- 7 DO NOT leave the sander operating whilst unattended.
- 7 DO NOT carry the sander with your finger on the power switch.
- 3 When not in use disconnect from mains power supply and store in a safe, dry, child proof area.



LEAD PAINT WARNING!

Paint once contained lead as a traditional ingredient. Contact with the dust from the removal of such paint is toxic and must therefore be avoided. The following action must be taken before using the sander on a surface that you suspect may have contained lead in the paint.

1. User must determine potential hazard relating to age of paint to be removed. (Modern paints do not have lead content).
2. **DANGER!** Keep all persons and pets away from the working area. The following persons are particularly vulnerable to the effects of lead paint dust: *Expectant women, Babies, and children.*
3. We recommend personal protection by using the following safety items:
 - a/ Paint Spray Respirator (Our ref SSP16EN)
 - b/ PE Coated Hooded Coverall (Our ref SSP266). c/ Latex Gloves (Our ref SSP24).
4. Take adequate measures to contain the paint dust, flakes, and scrapings.
5. Continue to wear safety equipment as in (3) above, and thoroughly clean all areas when task is complete. Ensure paint waste is disposed of in sealed bags or containers.

2. ASSEMBLY & TECHNICAL SPECIFICATIONS

The DAS150 has an alloy bevel gear head, a composite motor housing and carbon brush caps for quick brush replacement. The unit has a slider power on/off control with a power lock. Machine is not supplied with a sanding disc or pad. Discs and pads for DAS150/DFS have holes through which dust is extracted. The unit must be connected to a dust extraction system. Contact your Sealey dealer for details. DO NOT use a standard vacuum cleaner to extract dust as damage may result.

2.1. Assembly

p **WARNING!** DO NOT plug sander into the mains power supply before the machine is assembled.

Unpack the sander and check contents against figure 1 below. Should there be any damaged or missing parts contact your supplier immediately, (except item 4).

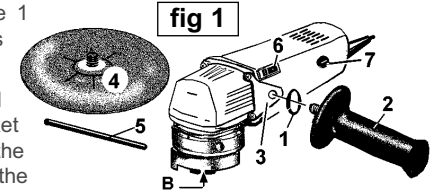

Place the spring washer (1) over the handle grip thread (2) and screw handle into the hole in the head side bracket (3). To place the handle on the right hand side, undo the side bracket hex screws and re-mount the side plate on the right ensuring all hex screws are re-tightened. Screw your sanding pad (NOT SUPPLIED) (4) into under side of rotating head (B). To remove pad, place bar wrench (5) into the grooves on the rotating head to hold the spindle steady whilst removing the pad.

2.2. SPECIFICATIONS:

DAS150

Power230V - 1.6A 380 Watts
No load speed6500 rpm
Orbit size8 mm
Thread 5/16" for use with pad size 150mm

DAS150/DFS

Power230V - 1.6A 380 Watts
No load speed6500 rpm
Orbit size8 mm
Weight2.2 kg
Thread 5/16" for use with pad size 150mm

DAS150 order pad No PTC/150A

DAS150/DFS order pad No:
AK289 or AK290.

Note:

DAS150 may be converted for use with dust free systems contact your Sealey dealer for details.

3. OPERATING INSTRUCTIONS

p **WARNING!** before use, ensure you have read and apply chapter 1 safety instructions.

- 3.1. Attach the correctly rated sanding disc to the self adhesive sanding pad.
- 3.2. Plug the sander into the mains power supply.

Grip the side handle and turn on by pushing switch (fig 1.6) switch forward. Let go of the switch and the machine will stop. To lock switch "on" press small button in switch head. To release lock, push the switch forward without touching the lock button. Check that the unit is working correctly before use.

Note: The sander is designed for dry use only. DO NOT use with water or any other liquids.

4. MAINTENANCE

- p **WARNING!** Disconnect sander from mains power supply before changing accessories, servicing or performing maintenance. Replace or repair damaged parts. Use genuine parts only. Non authorised parts may be dangerous and will invalidate the warranty.
- 4.1. After 50 hours initial use, remove dust from the end case by blowing air through the side vents and around the pad bearing. Periodic cleaning will prolong machine life.
 - 4.2. Change pads when required. Ensure pad and disc RPM rating is equal to, or exceeds the machine rating. If the disc becomes unbalanced, it will wear the bearings.
 - 4.3. Check brushes every 200 hours of use. To access remove plastic lugs located on each side of sander (fig1.7), (take care not to loose brush spring). Change brushes when worn to half original length, cracked or damaged. Failure to do so will damage armature and cause sparks.
 - 4.4. All other service and maintenance must be carried out by an authorised service agent.
 - 4.5. When not in use store in a safe, dry, childproof location.