



INSTRUCTIONS FOR

# EXTRA HEAVY DUTY GARAGE/WORKSHOP TROLLEY

MODEL NO: **CX102**

Thank you for purchasing a Sealey product. Manufactured to a high standard, this product will, if used according to these instructions, and properly maintained, give you years of trouble free performance.

**IMPORTANT:** PLEASE READ THESE INSTRUCTIONS CAREFULLY. NOTE THE SAFE OPERATIONAL REQUIREMENTS, WARNINGS & CAUTIONS. USE THE PRODUCT CORRECTLY AND WITH CARE FOR THE PURPOSE FOR WHICH IT IS INTENDED. FAILURE TO DO SO MAY CAUSE DAMAGE AND/OR PERSONAL INJURY AND WILL INVALIDATE THE WARRANTY. KEEP THESE INSTRUCTIONS SAFE FOR FUTURE USE.



Refer to  
Instruction  
manual

## 1. SAFETY

### 1.1. GENERAL SAFETY

- WARNING!** *Ensure Health & Safety, local authority, and general workshop practice regulations are adhered to when using this trolley.*
- ✓ Always load evenly with the centre of gravity of the load as near centre of the trolley as possible.
- ✗ **DO NOT overload the trolley - maximum weight per level is 80kg.**
- ✗ Use the trolley in a suitable work area.
- ✓ Keep the work area clean, uncluttered and ensure there is adequate lighting.
- ✓ Keep the trolley clean and tidy in accordance with good workshop practice.
- ✗ **DO NOT** use the trolley for any purpose other than that for which it is designed.
- ✗ **DO NOT** stand on the trolley, use it as a ladder or allow others to ride on the trolley.
- ✓ Use the wheel locks to prevent the trolley from inadvertently moving.
- ✗ **DO NOT** leave unattended, especially when loaded, unless the wheels are locked, chocked or the trolley otherwise secured.
- ✗ **DO NOT** use trolley on uneven ground and do not run over curbs or steps - use a ramp.
- ✗ **DO NOT** use trolley if any part is significantly damaged, paying particular attention to the wheels.
- ✓ Keep children and unauthorised persons away from the work area.

## 2. INTRODUCTION

Garage or workshop trolley with each shelf having a capacity of 80kg. Deep walled shelves, which may be installed base down or base up to give either tool and component security or unobstructed access. Fitted with four wheels, two fixed and two locking castors.

## 3. SPECIFICATION

Model no: .....**CX102**  
 Size (W x D x H): ..... 760 x 410 x 900 mm  
 Capacity: ..... 80kg/level



## 4. ASSEMBLY

- 4.1. Mount tray (2) to the upper hole in the end frames (3) and loosely fix with four M6 x 32mm bolts (1). Make sure the dished holes on the end frames are facing outwards.
- 4.2. Mount the other tray (2) to the lower hole in the end frames (3) and loosely fix with four M6 x 32mm bolts (1).
- 4.3. Tighten all bolts (1).
- 4.4. Turn the trolley over, install castors (4 & 5) into the bottom of the end frames and fix with the M6 x 12mm bolts (6).
- 4.5. Turn the trolley upright. The trolley is ready to use.

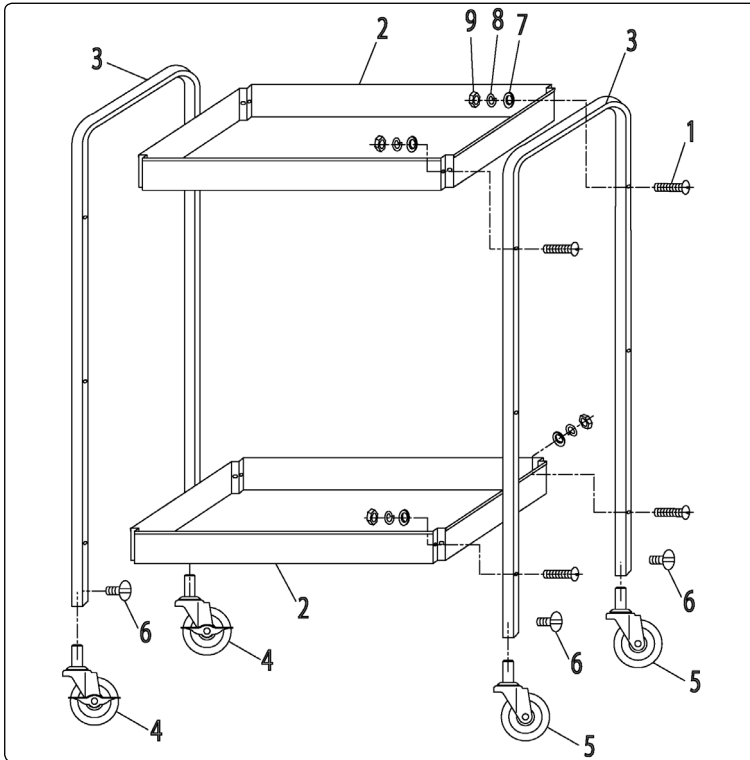

## 5. PARTS LIST

Item	Part No:	Description
1	CX101D.01	BOLT M6 x 32mm
2	CX101D.02	TRAY
3	CX101D.03	HANDLE
4	CX101D.04	CASTOR WHEEL c/w BRAKE
5	CX101D.05	CASTOR WHEEL
6	CX101D.06	BOLT M6 x 12mm
7	CX101D.08	WASHER
8	CX101D.09	SPRING WASHER
9	CX101D.10	NUT



### Environmental Protection

Recycle unwanted materials instead of disposing of them as waste. All tools, accessories and packaging should be sorted, taken to a recycling centre and disposed of in a manner which is compatible with the environment. When the product becomes completely unserviceable and requires disposal, drain off any fluids (if applicable) into approved containers and dispose of the product and the fluids according to local regulations.

**NOTE:** It is our policy to continually improve products and as such we reserve the right to alter data, specifications and component parts without prior notice.

**IMPORTANT:** No liability is accepted for incorrect use of this product.

**WARRANTY:** Guarantee is 12 months from purchase date, proof of which will be required for any claim.



Sole UK Distributor, Sealey Group.  
Kempson Way, Suffolk Business Park,  
Bury St. Edmunds, Suffolk.  
IP32 7AR



01284 757500



01284 703534



[www.sealey.co.uk](http://www.sealey.co.uk)



[sales@sealey.co.uk](mailto:sales@sealey.co.uk)