

Thank you for purchasing a Sealey product. Manufactured to a high standard this product will, if used according to these instructions and properly maintained, give you years of trouble free performance.

⚠ IMPORTANT: PLEASE READ THESE INSTRUCTIONS CAREFULLY. NOTE THE SAFE OPERATIONAL REQUIREMENTS, WARNINGS & CAUTIONS. USE THE PRODUCT CORRECTLY AND WITH CARE FOR THE PURPOSE FOR WHICH IT IS INTENDED. FAILURE TO DO SO MAY CAUSE DAMAGE AND/OR PERSONAL INJURY AND WILL INVALIDATE THE WARRANTY. PLEASE KEEP INSTRUCTIONS SAFE FOR FUTURE USE.

1. SAFETY INSTRUCTIONS

- ✓ Always distribute the load evenly over the surface of the bed.
- ✗ Do not overload the truck - see Specification.
- ✗ Do not leave unattended, especially when loaded, unless the wheels are chocked or the truck is otherwise secured.
- ✗ Do not use truck on uneven ground and do not run over curbs or steps - use a ramp.
- ✗ Do not allow others to ride on the truck.
- ✗ Do not use the truck if any part is damaged, paying particular attention to the wheels.
- ✗ Do not inflate the tyres more than 30p.s.i.

2. SPECIFICATION

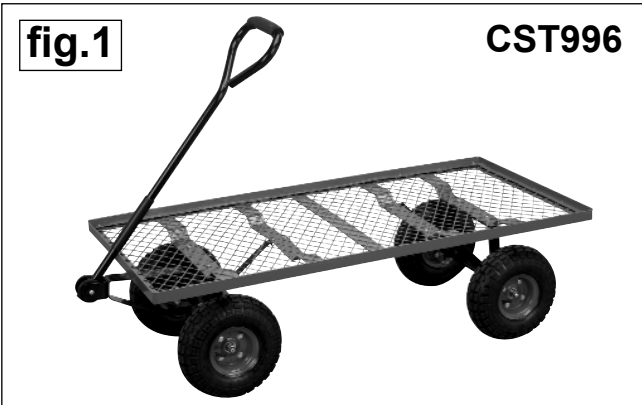

Model No.	CST996
Max. Load	200kg
Tyre Diameter	250mm
Tyre Thickness	90mm
Platform Height	350mm
Platform Width	590mm
Platform Length	1190mm
Model No.	CST997
Max. Load	200kg
Tyre Diameter	250mm
Tyre Thickness	90mm
Depth of Cart	240mm
Cart Width	480mm
Cart Length	930mm

3. INTRODUCTION

Heavy-duty steel construction with mesh decks. Cushioned grip pull handle with smooth steering action for easy manoeuvrability. Steel centred pneumatic wheels allow transport over the toughest terrain. CST997 has drop down sides which are also removable allowing use as a flatbed for oversized items. Suitable for a variety of warehouse, office, garden and domestic hauling applications.

4. ASSEMBLY

- 4.1 Check contents against the parts list, if anything is missing or damaged contact your local Sealey dealer.
- 4.2 Turn the truck bed upside down and lay it on a level floor with something underneath it to prevent it being scratched.
- 4.3 Bolt the rear axle support (see fig.2-3) to the bed using two 8 x 20mm bolts, two washers and two 8mm nuts (see fig.2-20).
- 4.4 Slide one end of each rear axle brace (see fig.2-4&5) over the axle and bolt each one to the bed as indicated in fig.2 using two 8 x 20mm bolts, two washers and two 8mm nuts for each brace. Tighten all nuts securely.

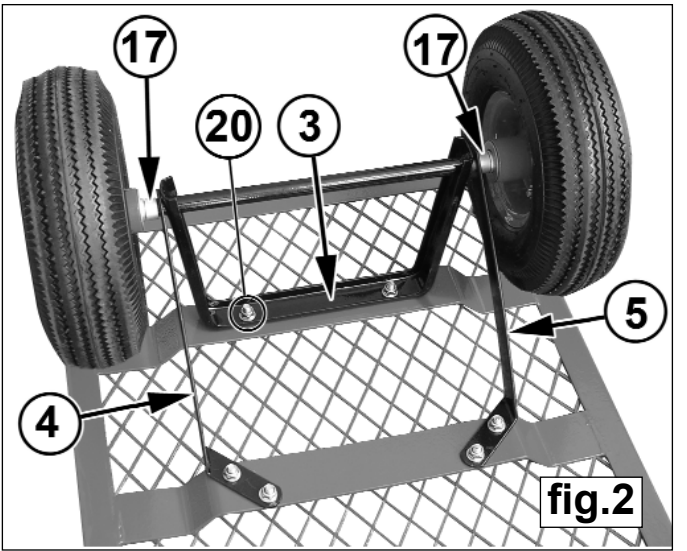

- 4.5 Assemble the front support/steering assembly completely before bolting it to the bed.
- 4.6 Attach the steering link connector to the axle guides (see fig.3-9) using two 8 x 15 short shoulder bolts with matching nuts and washers. NOTE: Attach the steering link connector on the bed side of the axle guides.
- 4.7 Place the yoke (see fig.3-8) into position in the steering assembly ensuring that the short arm of the yoke drops onto the pivot pin in the centre of the front axle support (see fig.3-A). Secure in position using a cotter pin through the hole in the end of the pivot pin.
- 4.8 Bolt the long arm of the yoke to the steering link connector using one 8 x 15 short shoulder bolt with matching 6mm nut and washer.
- 4.9 Attach the centre front axle brace (see fig.3-7) to the steering assembly at point 'C'. Use the long shoulder bolt together with matching 6mm nut and washer.
- 4.10 Now bolt the whole steering assembly to the bed. Use two 8 x 20mm bolts to fix the front axle support at points 'B' x 2 and two 8 x 20mm bolts to fix the centre brace at point 'D'.

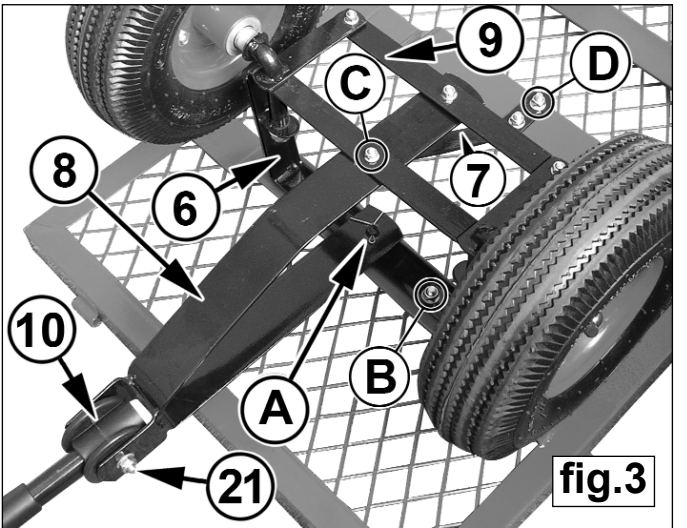

- 4.11 Slide wheel spacer bushings onto both the front and rear axles. Place a wheel onto each axle with the valve stem facing outwards. Place a plain 12mm washer onto each axle followed by spring washer and secure each wheel with a 12mm dome nut.
- 4.12 Turn the cart upright onto its wheels and attach the pull handle using the plastic coupling. Secure with the 8 x 60mm pull handle bolt, washer and nut.
- 4.13 **CST997 ONLY drop down sides**
Attach each hinged side-piece to the bed using the quick release pins provided (See fig.5-A). Attach the side with the cut out portion to the handle end of the bed.(See fig.4)

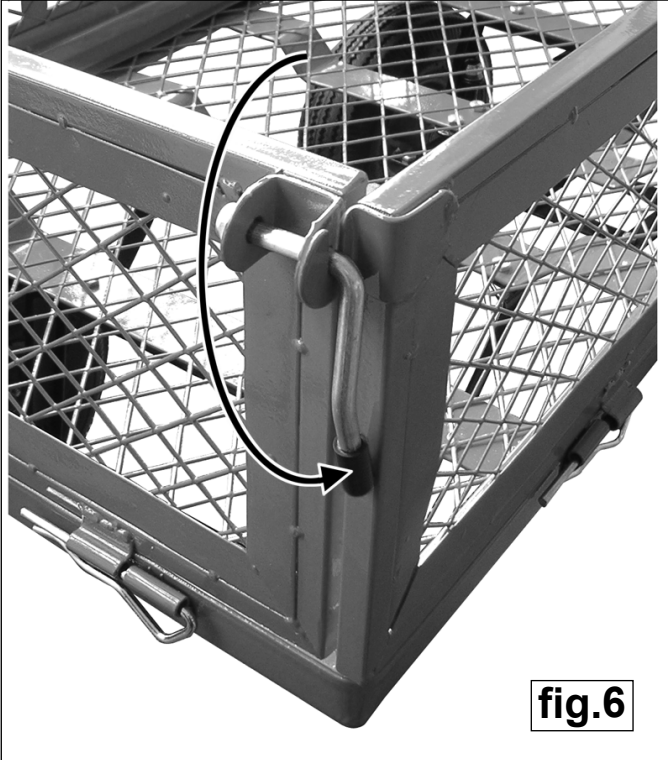

fig.6



fig.4

5. TRUCK OPERATION

- 4.14 To raise and lock the sides of the truck lift one end-piece first and move the locking handle (see fig.5-B) into the vertical position. Raise the adjacent side-piece so that the locking handle passes through the slotted tongue on the side-piece. Now swing the handle downwards to lock the side-piece in position (see Fig.6). Repeat the process for all four corners so that the truck is assembled as shown in fig.7.

- 5.1. Check tyre pressures on the truck on a regular basis. Do not inflate above 30psi.
- 5.2. Do not overload the truck and ensure that the load is evenly distributed before setting off.
- 5.3. When towing the truck proceed at a safe speed especially at corners where there could be a danger of the load shifting.
- 5.4. When using as a flat bed truck do not transport loads with an excessive overhang.
- 5.5. Extra care should be taken on inclined surfaces.
- 5.6. If the truck is loaded and left unattended the wheels should be chocked.
- 5.7. Where there is a curb or step a ramp should be used.
- 5.8. When using the CST997 as a flat bed truck remove all sides so as not to restrict the turning circle.

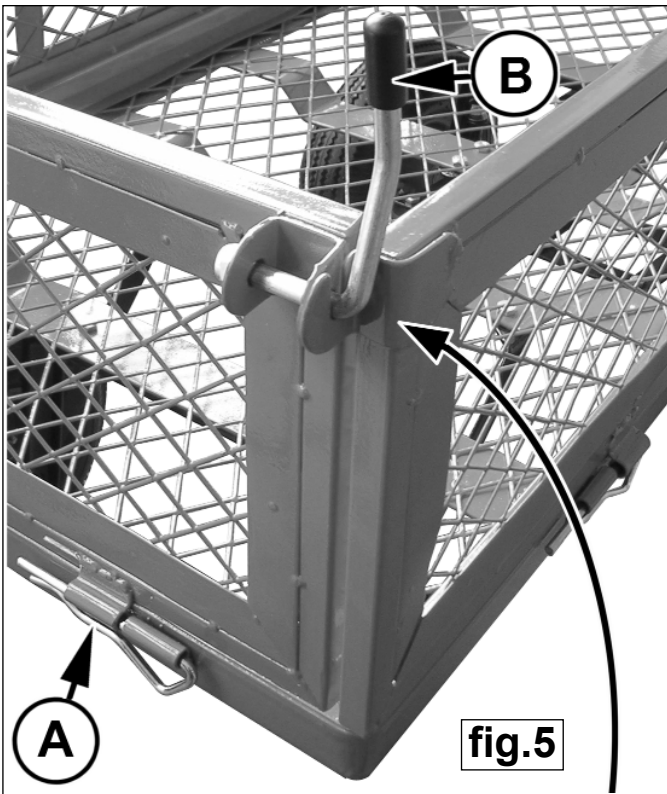

fig.5



fig.7

CST997