



# STAIR CLIMBING SACK TRUCK

MODEL NO: **CST985.V3**

Thank you for purchasing a Sealey product. Manufactured to a high standard, this product will, if used according to these instructions, and properly maintained, give you years of trouble free performance.

**IMPORTANT:** PLEASE READ THESE INSTRUCTIONS CAREFULLY. NOTE THE SAFE OPERATIONAL REQUIREMENTS, WARNINGS & CAUTIONS. USE THE PRODUCT CORRECTLY AND WITH CARE FOR THE PURPOSE FOR WHICH IT IS INTENDED. FAILURE TO DO SO MAY CAUSE DAMAGE AND/OR PERSONAL INJURY AND WILL INVALIDATE THE WARRANTY. KEEP THESE INSTRUCTIONS SAFE FOR FUTURE USE.



Refer to instructions

## 1. SAFETY

- ✓ Always load evenly with the centre of gravity of the load as low as possible.
- ✓ Use additional support for large or wide loads to prevent movement.
- ✓ When used on steps or stairs ensure that the load is well within your capability to lift and control. Make multiple trips rather than exceed your lifting capabilities.
- ✗ **DO NOT** overload the truck - maximum capacity 150kg.
- ✗ **DO NOT** allow others to ride on the truck.
- ✗ **DO NOT** use the truck if any part is damaged.

## 2. INTRODUCTION

Tubular steel construction gives 150kg maximum load capacity. Deep foot ensures cartons stay on trolley during transit. Fitted with solid rubber wheels. Handle design allows a firm grip whilst ascending and descending stairways. Ideal for delivery drivers and couriers. Suitable also for multi-level factories and offices.

## 3. SPECIFICATION

Model No: ..... CST985.V3  
 Max. Load. .... 150kg  
 Wheel Diameter. .... 165mm  
 Wheel Width. .... 30mm  
 Height. .... 1300mm  
 Width (overall) .... 510mm  
 Platform Depth. .... 230mm  
 Nett Weight. .... 16kg

## 4. ASSEMBLY

**Note:** Numbers/Letters in brackets refer to the parts in (Fig 1.)

- 4.1. Slide axle (C) through tubes (A).
- 4.2. Fit wheel assembly (1) to each end of axle and retain with plain washers and nuts (2).
- 4.3. Slide handle (D) over tubes (B) and retain with bolts, plain washers and nuts (2).

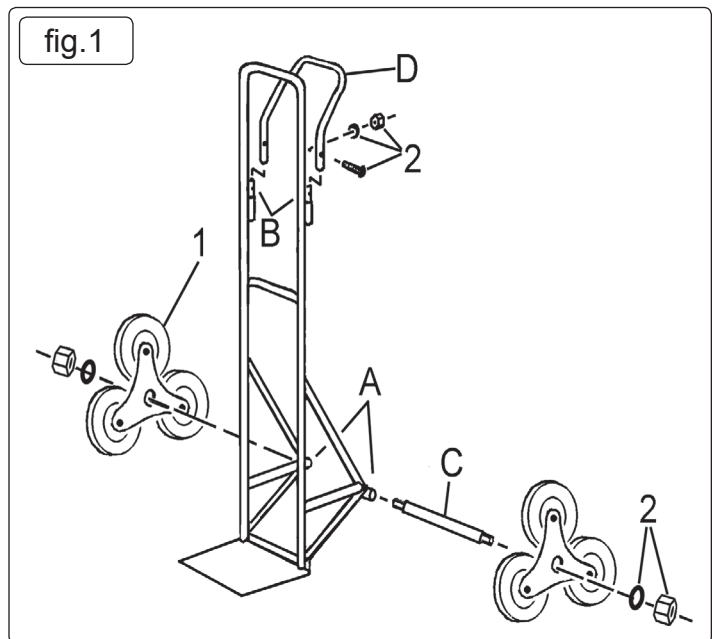

### ENVIRONMENT PROTECTION

Recycle unwanted materials instead of disposing of them as waste. All tools, accessories and packaging should be sorted, taken to a recycling centre and disposed of in a manner which is compatible with the environment. When the product becomes completely unserviceable and requires disposal, drain any fluids (if applicable) into approved containers and dispose of the product and fluids according to local regulations.

**Note:** It is our policy to continually improve products and as such we reserve the right to alter data, specifications and component parts without prior notice.

**Important:** No Liability is accepted for incorrect use of this product.

**Warranty:** Guarantee is 12 months from purchase date, proof of which is required for any claim.

Sealey Group, Kempson Way, Suffolk Business Park, Bury St Edmunds, Suffolk. IP32 7AR



01284 757500



01284 703534



sales@sealey.co.uk



www.sealey.co.uk

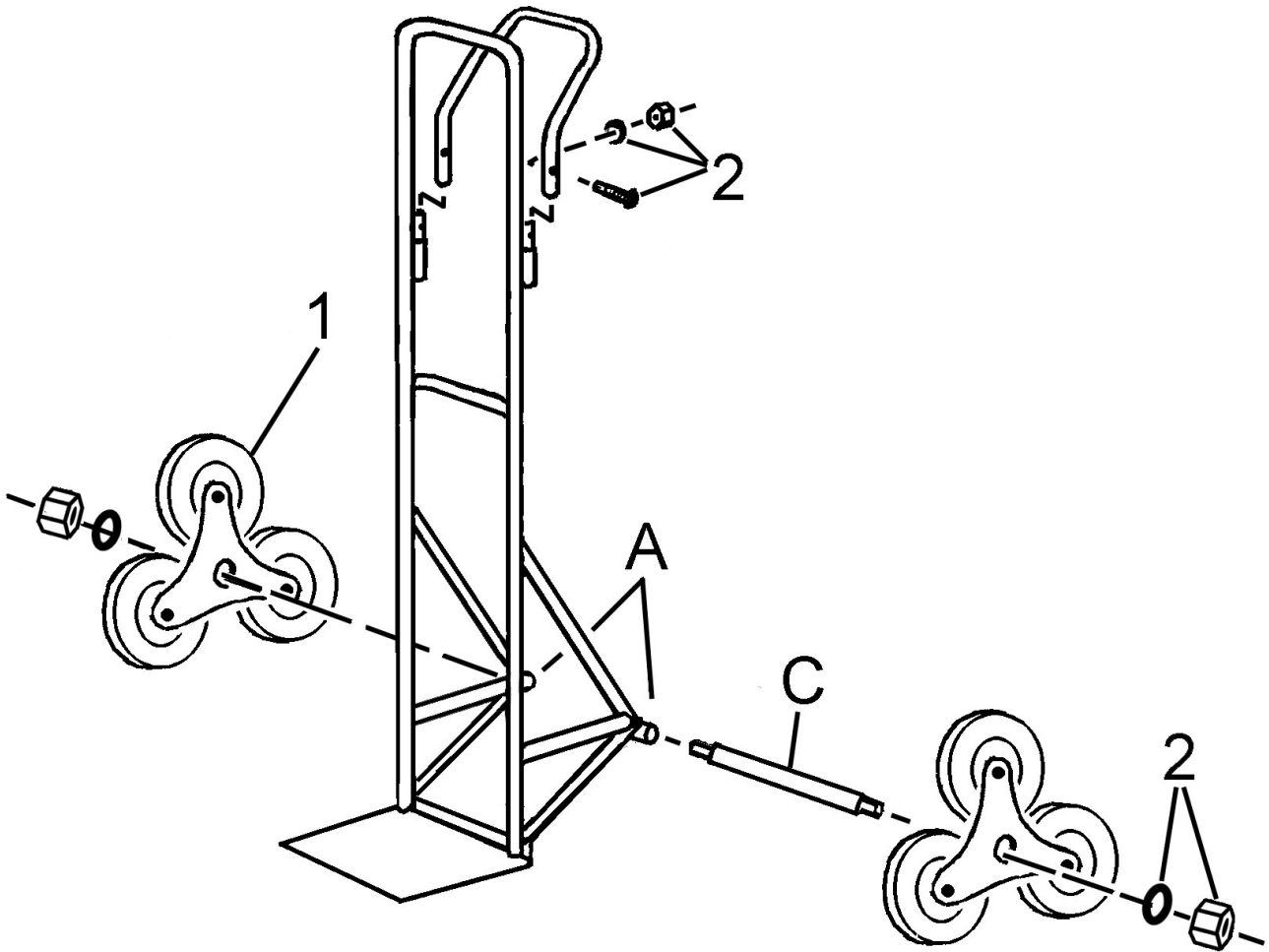

Item	Part No.	Description
1	CST985.V3-01	WHEEL, FIXED (161x23x42)
2	CST985.V3-02	FIXINGS

Item	Part No.	Description
A	CST985.V3-03	WHEEL FRAME
C	CST985.V3-04	AXLE

**NOTE:** It is our policy to continually improve products and as such we reserve the right to alter data, specifications and component parts without prior notice.

**IMPORTANT:** No liability is accepted for incorrect use of product.

**WARRANTY:** Guarantee is 12 months from purchase date, proof of which will be required for any claim.