



INSTRUCTIONS FOR

# CORDLESS LITHIUM-ION NAIL/STAPLE GUN 18G 18V

MODEL NO: **CPNG18**

Thank you for purchasing a Sealey product. Manufactured to a high standard, this product will, if used according to these instructions, and properly maintained, give you years of trouble free performance.

**IMPORTANT:** PLEASE READ THESE INSTRUCTIONS CAREFULLY. NOTE THE SAFE OPERATIONAL REQUIREMENTS, WARNINGS & CAUTIONS. USE THE PRODUCT CORRECTLY AND WITH CARE FOR THE PURPOSE FOR WHICH IT IS INTENDED. FAILURE TO DO SO MAY CAUSE DAMAGE AND/OR PERSONAL INJURY AND WILL INVALIDATE THE WARRANTY. KEEP THESE INSTRUCTIONS SAFE FOR FUTURE USE.



Refer to instructions



Wear eye protection



Wear protective gloves



Wear ear protection



Keep People Away



Indoor use Only

## 1. SAFETY

### 1.1. Electrical Safety

- ❑ **WARNING!** It is the user's responsibility to check the following:  
Check all electrical equipment and appliances to ensure that they are safe before using. Inspect power supply leads, plugs and all electrical connections for wear and damage. Sealey recommend that an RCD (Residual Current Device) is used with all electrical products. You may obtain an RCD by contacting your local Sealey dealer.  
if the used in the course of business duties, it must be maintained in a safe condition and routinely PAT (Portable Appliance Test) tested.
- ✓ Electrical safety information, it is important that the following information is read and understood.
- ✓ Ensure that the insulation on all cables and on the appliance is safe before connecting it to the power supply.
- ✓ Regularly inspect power supply cables and plugs for wear or damage and check all connections to ensure that they are secure.
- ✓ Ensure that the voltage rating on the appliance suits the power supply to be used and that the plug is fitted with the correct fuse - see fuse rating in these instructions.
- ✗ **DO NOT** pull or carry the appliance by the power cable.
- ✗ **DO NOT** pull the plug from the socket by the cable. Remove the plug from the socket by maintaining a firm grip on the plug.
- ✗ **DO NOT** use worn or damaged cables, plugs or connectors. Ensure that any faulty item is repaired or replaced immediately by a qualified electrician.

This product is fitted with a BS1363/A 13 Amp 3 pin plug.

If the cable or plug is damaged during use, switch off the electricity supply and remove from use.

Replace a damaged plug with a BS1363/A 13 Amp 3 pin plug. If in doubt contact a qualified electrician.

Class II products are wired with live (brown) and neutral (blue) only are marked with the Class II symbol;

A) Connect the BROWN live wire to the live terminal 'L'.

B) Connect the BLUE neutral wire to the neutral terminal 'N'.

C) After wiring, check that there are no bare wires and ensure that all wires have been correctly connected.



Ensure that the cable outer sheath extends inside the cable restraint and that the restraint is tight.

**DO NOT** connect either wire to the earth terminal.

Sealey recommend that repairs are carried out by a qualified electrician.

### 1.2. General Safety

Always assume that the tool contains fasteners. Careless handling of the tacker can result in unexpected firing of fasteners and personal injury.

- ✗ **DO NOT** point the tool towards yourself or anyone nearby. Unexpected triggering will discharge the fastener causing an injury.
- ✗ **DO NOT** actuate the tool unless the tool is placed firmly against the workpiece. If the tool is not in contact with the workpiece, the fastener may be deflected away from your target.
- ✓ Remove battery if the fastener jams in the tool. While removing a jammed fastener, the tacker may be accidentally activated if there is a power supply attached.
- ✓ Use caution while removing a jammed fastener. The mechanism may be under compression and the fastener may be forcefully discharged while attempting to free a jammed condition.
- ✗ **DO NOT** use this tacker for fastening electrical cables. It is not designed for electric cable installation and may damage the insulation of electric cables thereby causing electric shock or fire hazard.
- ✓ Recharge only with the charger and the battery packs specified by the manufacturer.
- ✓ Ensure the switch is in the off position before inserting battery pack.
- ✗ **DO NOT** open the battery. Danger of short-circuiting.
- ✓ Protect the battery against heat, e.g., also against continuous sun irradiation and fire. There is danger of explosion.
- ✗ **DO NOT** short-circuit the battery. There is danger of explosion.
- ✓ Battery leakage (liquid ejection). Under abusive conditions, liquid may be ejected from the battery; avoid contact. If contact accidentally occurs, flush with water. If liquid contacts eyes, flush them with clean water for at least 10 minutes, then seek immediate

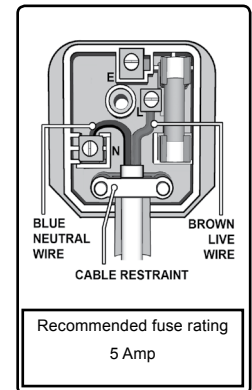

medical attention. Liquid ejected from the battery may cause irritation or burns.

- ✓ Make sure cord for the charger is located so that it will not be stepped on, tripped over, or otherwise subjected to damage or stress.
- ✗ **DO NOT** operate charging system with damaged cord or plug.

**☐ WARNING! – Risk of Hand Arm Vibration Injury.**

This tool may cause Hand Arm Vibration Syndrome if its use is not managed adequately.  
This tool is subject to the vibration testing section of the Machinery Directive 2006/42/EC.  
This tool is to be operated in accordance with these instructions.

Measured vibration emission value (a): ..... 1.39 m/s<sup>2</sup>  
Uncertainty value (k): ..... 1.5 m/s<sup>2</sup>

Please note that the application of the tool to a sole specialist task may produce a different average vibration emission. We recommend that a specific evaluation of the vibration emission is conducted prior to commencing with a specialist task.

A health and safety assessment by the user (or employer) will need to be carried out to determine the suitable duration of use for each tool.

NB: Stated Vibration Emission values are type-test values and are intended to be typical.

Whilst in use, the actual value will vary considerably from and depend on many factors.

Such factors include; the operator, the task and the inserted tool or consumable.

NB: ensure that the length of leader hoses is sufficient to allow unrestricted use, as this also helps to reduce vibration.

The state of maintenance of the tool itself is also an important factor, a poorly maintained tool will also increase the risk of Hand Arm Vibration Syndrome.

Health surveillance.

We recommend a programme of health surveillance to detect early symptoms of vibration injury so that management procedures can be modified accordingly.

Personal protective equipment.

We are not aware of any personal protective equipment (PPE) that provides protection against vibration injury that may result from the uncontrolled use of this tool. We recommend a sufficient supply of clothing (including gloves) to enable the operator to remain warm and dry and maintain good blood circulation in fingers etc. Please note that the most effective protection is prevention, please refer to the Correct Use and Maintenance section in these instructions. Guidance relating to the management of hand arm vibration can be found on the HSC website [www.hse.gov.uk](http://www.hse.gov.uk) - Hand-Arm Vibration at Work.

## 2. INTRODUCTION

Powerful, compact cordless nail and staple gun can drive up to 50mm 18G nails or 40mm 18G staples into wood, without compressed air or mains power supply. Robust composite housing incorporates two LED lights for use in low light areas. Selectable single or contact firing allows use for different applications. Features an adjustable drive depth wheel for accurate results. Safety trigger device prevents accidental firing of nails or staples. Supplied in carry case with charger, battery pack and a starter pack of nails and staples.

## 3. SPECIFICATION

Model No.....CPNG18  
Battery ..... 18V 2Ah Li-ion  
Nail Capacity.....20-50mm 18SWG  
Staple Capacity.....19-40mm 18SWG  
Replacement Battery..... CPNG18BP  
Weight..... 3kg  
Noise Power/Pressure ..... 91dB/80dB

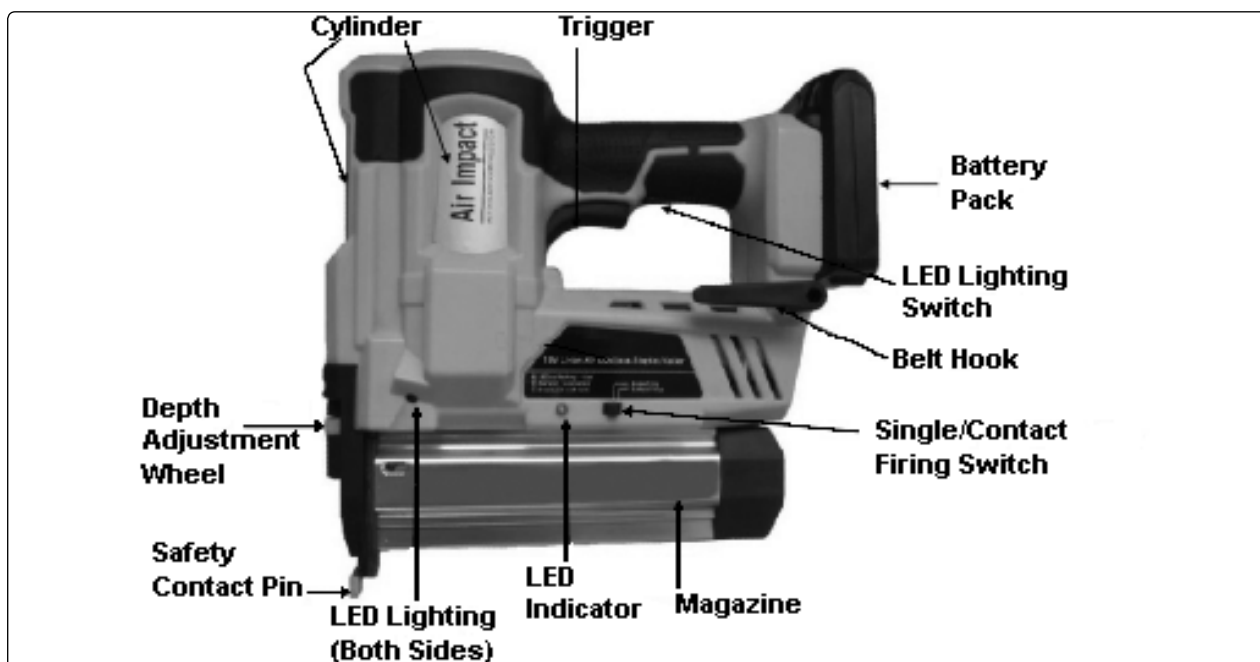

## 4. OPERATION

The machine is intended for tacking of cardboard, insulating material, fabric, foils, leather and similar materials on surfaces of wood or materials similar to wood. The machine is not suitable for the attachment to brick, concrete etc.

### 4.1. LED Indicator

4.1.1. The LED will be on to indicate status of power tool and charger:

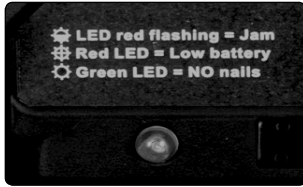

- a) Red LED on = low battery
- b) Red LED flashing = nails/staples are jammed
- c) Green LED on = No nails
- d) Green LED flashing = Overheating, tool in overheat mode

Charger:

- a) Red LED on=battery charging.
- b) Green LED on=battery fully charged.

### 4.2. Battery Charging

4.2.1. Battery packs for this tool are shipped in a low charge condition to prevent possible problems.

4.2.2. Push the battery pack into the charger base. Plug the charger power supply into a power outlet. Insert the power outlet into the port on battery pack. The indicator light on the charger will be red (battery is charging).

4.2.3. When batteries become fully charged (about 1~1.5 hours), the indicator on the charger will turn green. Unplug the charger from power supply and remove the battery pack.

**NOTE:** A battery that is new or has not been used for a longer period does not develop its full capacity until after approx. 5 charge/discharge cycles.

4.2.4. **DO NOT** recharge the batteries after use if they are not to be used for an extended period of time. Recharge the batteries as and when they are required.

### 4.3. Inserting and Removing the Battery

4.3.1. Insert the battery pack into the grip until it clicks in place.

4.3.2. To remove the battery pack, with pressing the lock buttons simultaneously to pull the pack out of the machine.

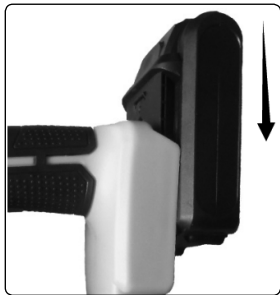

(image a)

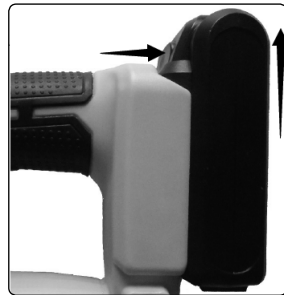

(image b)

### 4.4. LED Lighting

4.4.1. Two Led lights one in each side can be turned on when the machine is working.

### 4.5. Checking the contact trip mechanism

4.5.1. Remove all staples or nails from the magazine.

4.5.2. Press the safety nose/contact pin and pull the trigger. The safety nose/contact pin and the trigger should move freely.

4.5.3. Reload the staples or nails to the magazine.

4.5.4. **DO NOT** use the tool if the safety nose/contact pin cannot move freely.

4.5.5. Place the contact pin on the workpiece and press the machine without pulling the trigger, the machine should not fire ; Take the machine from the workpiece, the contact pin should spring back automatically. Pull the trigger, The machine should not fire.

### 4.6. Inserting Staples or Nails into the magazine

**NOTE:** The number of staples or nails left in the magazine can be read using the viewing window.

4.6.1. Remove battery pack from the tool.

4.6.2. Press the release button and pull out the magazine cover.

4.6.3. Tilt the tool and place nails/staples into the track of the magazine channel.

4.6.4. Make sure that the fasteners are placed correctly: (see overleaf)

a) Staples are placed against the profiled side of the rail, the crown of the staple is in the uppermost part of the magazine(legs are facing away from the body of the tool).

b) Nails are placed against the profiled side of the rail, with the points of the nails facing downwards.

4.6.5. Close the magazine cover until it engages with the release button.

**NOTE:** The number of staples or nails left in the magazine can be read using the viewing window.

Reattach battery pack to tool.

**Warning: DO NOT** place fasteners of different length. **DO NOT** place staples and nails mixed together.

A.Loading staples:



B. Loading nails:



4.7. **Instructions for use**

- 4.7.1. Prior to operation make sure your battery pack is fully charged.
- 4.7.2. Check whether the fasteners are placed in the magazine correctly.

4.8. **Nailing or Stapling**

- 4.8.1. Hold handle firmly with magazine flat to work piece forming a 90° Angle.
- 4.8.2. Two modes of firing: Single Firing and Contact Firing.

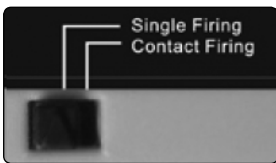

4.9. **Single Firing Mode:**

- 4.9.1. Push the drive shift (single/contact firing knob) to left side, it is on Single Firing mode . Single Firing is good for precision placement .
- 4.9.2. Push the drive shift to left side.



- 4.9.3. Depress the safety contact pin against the work piece



- 4.9.4. Squeeze the trigger to fire the staple or nail ; Released the trigger and safety contact pin after firing.



- 4.9.5. Firing next staple or nail, repeat step 4.9.3 and step 4.9.4
- 4.9.6. The safety contact pin must be depressed before the trigger is squeezed.

**4.10. Contact Firing Mode:**

- 4.10.1. Push the single/contact firing switch to the right side, it is on Contact Firing mode.
- 4.10.2. Contact Firing is good for quick and convenient firing.



- 4.10.3. Squeeze the trigger , keep squeezing and don't release.



- 4.10.4. Depress the safety contact pin against the work piece to fire the nail or staple; Keep squeezing the trigger all the time but released safety contact pin after firing.



- 4.10.5. Firing next staple or nail , repeat step 4.10.4
- 4.10.6. The trigger must be kept depressed all the time so that every time the safety contact pin is depressed the tool is activated.
- 4.10.7. **DO NOT** keep the trigger depressed when the tool is not in use.
- 4.10.8. A significantly reduced working period after charging indicated that the battery is used and must be replaced.

**4.11. Depth Adjustment Wheel**

- 4.11.1. Depth adjustment helps protect work surface and allows proper setting of nail heads



- 4.11.2. Turn the depth adjustment wheel to alter the depth of penetration of the nails/staples.

#### 4.12. Removing a jammed nail or staple

**Note:** You must remove any jammed nail/staple before using the tool any further. Otherwise, it could cause damage to the mechanism.

4.12.1. Remove the battery pack from the tool.

4.12.2. Open the magazine, remove the staples or nails in channel. Then, to remove the jammed fasteners.

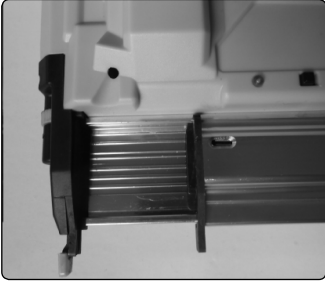

4.12.3. If the fasteners remain jammed after following the above instructions, slightly loosen the hex screws on the nose piece with the wrench provided then remove the jammed fasteners pieces see below , only loosen these two screws , **DO NOT** loosen other screws, **DO NOT** remove the whole nozzle cover.

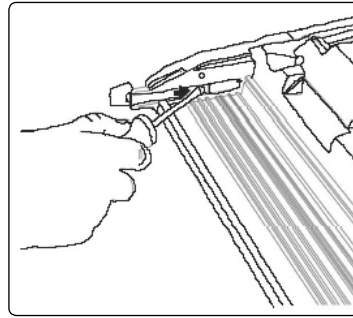
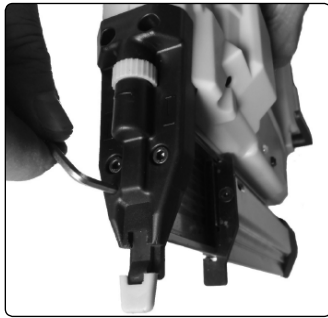

4.12.4. Remove the jammed nail with pliers if necessary. After the jammed nail has been successfully removed , then re-tighten the nose piece with hex screws securely.

Sometimes after a jam, the driver remains stuck and does not return to its position. Take a flat screwdriver and push it back into place.

4.12.5. Reload the staples/nails, close the magazine, then insert the battery.

- ❑ Warning: Do not attempt to destroy or disassemble battery pack or remove any of its components. Also, never touch the battery terminals with metal objects and/or body parts as short circuit may result. Keep away from children.

## 5. MAINTENANCE

Have your power tool serviced by a qualified repair person using only identical replacement parts. This will ensure that the safety of the power tool is maintained.

**Parts support is available for this product. To obtain a parts listing and/or diagram, please log on to [www.sealey.co.uk](http://www.sealey.co.uk), email [sales@sealey.co.uk](mailto:sales@sealey.co.uk) or telephone 01284 757500.**



#### Environmental Protection

Recycle unwanted materials instead of disposing of them as waste. All tools, accessories and packaging should be sorted, taken to a recycling centre and disposed of in a manner which is compatible with the environment. When the product becomes completely unserviceable and requires disposal, drain off any fluids (if applicable) into approved containers and dispose of the product and the fluids according to local regulations.



#### WEEE Regulations

Dispose of this product at the end of its working life in compliance with the EU Directive on Waste Electrical and Electronic Equipment (WEEE). When the product is no longer required, it must be disposed of in an environmentally protective way. Contact your local solid waste authority for recycling information.



#### Battery Removal

See section 4.3

Under the Waste Batteries and Accumulators Regulations 2009, Jack Sealey Ltd are required to inform potential purchasers of products containing batteries (as defined within these regulations), that they are registered with Valpak's registered compliance scheme. Jack Sealey Ltd's Batteries Producer Registration Number (BPRN) is BPRN00705.

**NOTE:** It is our policy to continually improve products and as such we reserve the right to alter data, specifications and component parts without prior notice.

**IMPORTANT:** No liability is accepted for incorrect use of this product.

**WARRANTY:** Guarantee is 12 months from purchase date, proof of which will be required for any claim.



Sole UK Distributor, Sealey Group.  
Kempson Way, Suffolk Business Park,  
Bury St. Edmunds, Suffolk.  
IP32 7AR



01284 757500



01284 703534



[www.sealey.co.uk](http://www.sealey.co.uk)



[sales@sealey.co.uk](mailto:sales@sealey.co.uk)