

Thank you for purchasing a Sealey product. Manufactured to a high standard this product will, if used according to these instructions and properly maintained, give you years of trouble free performance.

⚠ IMPORTANT: PLEASE READ THESE INSTRUCTIONS CAREFULLY. NOTE THE SAFE OPERATIONAL REQUIREMENTS, WARNINGS, AND CAUTIONS. USE THIS PRODUCT CORRECTLY, AND WITH CARE FOR THE PURPOSE FOR WHICH IT IS INTENDED. FAILURE TO DO SO MAY CAUSE DAMAGE AND/OR PERSONAL INJURY AND WILL INVALIDATE THE WARRANTY.

1. SAFETY INSTRUCTIONS

1.1 ELECTRICAL SAFETY

- ❑ **WARNING!** It is the responsibility of the owner and the operator to read, understand and comply with the following:
 - You must check all electrical products, before use, to ensure that they are safe. You must inspect power cables, plugs, sockets and any other connectors for wear or damage. You must ensure that the risk of electric shock is minimised by the installation of appropriate safety devices. A Residual Current Circuit Breaker (RCCB) should be incorporated in the main distribution board. We also recommend that a Residual Current Device (RCD) is used. It is particularly important to use an RCD with portable products that are plugged into a supply which is not protected by an RCCB. If in any doubt consult a qualified electrician. You may obtain a Residual Current Device by contacting your Sealey dealer.
 - You must also read and understand the following instructions concerning electrical safety.
- 1.1.1 The Electricity at Work Act 1989 requires that all portable electrical appliances, if used on business premises, are tested by a qualified electrician, using a Portable Appliance Tester (PAT), at least once a year.
- 1.1.2 The Health & Safety at Work Act 1974 makes owners of electrical appliances responsible for the safe condition of those appliances and the safety of the appliance operators. If in any doubt about electrical safety, contact a qualified electrician.
- 1.1.3 Ensure that the insulation on all cables and on the appliance is safe before connecting it to the power supply. See 1.1.1 and 1.1.2 and use a Portable Appliance Tester.
- 1.1.4 Ensure that cables are always protected against short circuit and overload.
- 1.1.5 Regularly inspect power supply cables and plugs for wear or damage and check all connections to ensure that none is loose.
- 1.1.6 Important: Ensure that the voltage marked on the appliance matches the power supply to be used and that the plug is fitted with the correct fuse - see fuse rating at right.
- 1.1.7 DO NOT pull or carry the appliance by the power cable.
- 1.1.8 DO NOT pull the plug from the socket by the cable.
- 1.1.9 DO NOT use worn or damaged cables, plugs or connectors. Immediately have any faulty item repaired or replaced by a qualified electrician. When a BS 1363/A UK 3 pin plug is damaged, cut the cable just above the plug and dispose of the plug safely. Fit a new plug according to the following instructions (UK only).
 - a) Connect the GREEN/YELLOW earth wire to the earth terminal 'E'.
 - b) Connect the BROWN live wire to the live terminal 'L'.
 - c) Connect the BLUE neutral wire to the neutral terminal 'N'.
 - d) After wiring, check that there are no bare wires, that all wires have been correctly connected, that the cable outer insulation extends beyond the cable restraint and that the restraint is tight. Double insulated products, which are always marked with this symbol , are fitted with live (brown) and neutral (blue) wires only. To rewire, connect the wires as indicated above - DO NOT connect either wire to the earth terminal.
- 1.1.10 Products which require more than 13 amps are supplied without a plug. In this case you must contact a qualified electrician to ensure that a suitably rated supply is available. We recommend that you discuss the installation of an industrial round pin plug and socket with your electrician.
- 1.1.11 If an extension reel is used it should be fully unwound before connection. A reel with an RCD fitted is preferred since any appliance plugged into it will be protected. The cable core section is important and should be at least 1.5mm², but to be absolutely sure that the capacity of the reel is suitable for this product and for others which may be used in the other output sockets, we recommend the use of 2.5mm² section cable.

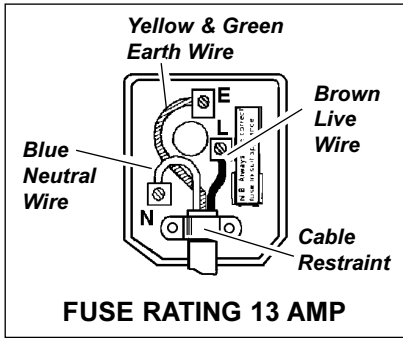

1.2 GENERAL SAFETY

- ❑ **WARNING!** Disengage the grease gun from the battery before changing accessories, servicing or performing and maintenance.
- ✓ Maintain gun in good condition (use an authorised service agent).
- ✓ Replace or repair damaged parts. *Use recommended parts only. Unauthorised parts may be dangerous and will invalidate the warranty.*
- ✓ Wear appropriate protective clothing. When handling lubricants refer to manufacturer's instructions and conform to local regulations.
- ✓ Use the gun in a suitable working area. Keep area clean and tidy and free from unrelated materials and ensure there is adequate lighting.

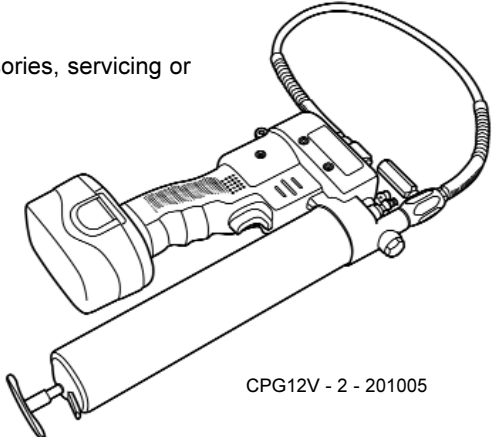

- ✓ Maintain correct balance and footing whilst performing the task. Ensure floor is not slippery and wear non-slip shoes.
- ✓ Keep children and unauthorised persons away from the work area.
- ✓ Dispose of waste grease in accordance with local authority regulations.
- ✓ When not in use ensure the battery is removed.
- ✗ DO NOT allow unauthorised persons to operate the gun.
- ☐ **WARNING!** DO NOT tamper with or open pump unit. Doing so will invalidate your warranty.
- ✗ DO NOT point grease gun at yourself or other persons or animals.
- ✗ DO NOT pull the grease gun unit by the hose.
- ✗ DO NOT use the gun for a task it is not designed to perform.
- ✗ DO NOT operate the gun when you are tired or under the influence of alcohol, drugs or intoxicating medication.
- ✓ When not in use, clean the unit and store in a dry, safe, childproof area.

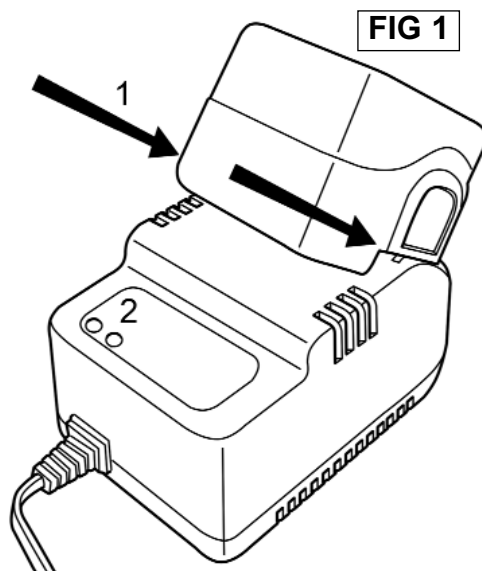

2. INTRODUCTION & SPECIFICATION

A battery powered grease gun, developing 6000psi, to simplify and speed-up manual greasing. Suitable for 400g cartridges, manual or bulk filling. Supplied with battery, mains charger and in-car adaptor. Supplied in a robust storage/carry-case.

Voltage:12V
 Pressure:6000psi
 Hose Length:650mm
 Replacement Battery:CPG12VBP

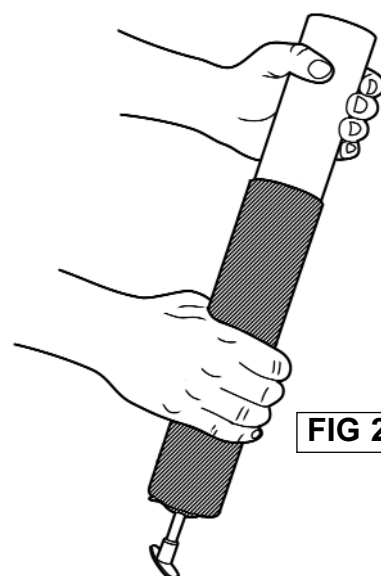

3. OPERATION

3.1 CHARGING THE BATTERY

Important: Before using the grease gun for the first time the battery must be charged for a minimum 1.5 hours.

- 3.1.1 To charge the battery simply slot the battery onto the charger (fig 1.1).
- ☐ **WARNING!** Do not obstruct the vents situated on the top and bottom of the charger as this will cause the charger to overheat.
- 3.1.2 Once plugged in correctly and the mains has been switched on, the red light situated at the front of the charger (fig 1.2) will illuminate, when charging is complete the green light will illuminate.
- 3.1.3 Use of the optional in-car charger is identical to using the mains charger, however, ensure the surface, which the charger is situated on, is sturdy and heat resistant as the unit may get hot during a charge.

3.2 REMOVING THE BATTERY PACK

- 3.2.1 To remove the battery from the unit simply press the two buttons located each side of the battery simultaneously and pull the battery away from the body.
- 3.2.2 To insert the battery, line up the ridges on the battery with the slots on the handle base and push towards the unit firmly until you hear a click.

3.3 CARTRIDGE LOADING

- 3.3.1 Unscrew the grease tube from the grease gun.
- 3.3.2 Fully draw back the plunger handle.
- 3.3.3 Insert the open end of the cartridge into the grease tube and push it all the way in (fig 2). Remove the seal or pull tab end from the cartridge.
- 3.3.4 Screw the grease tube back in to the grease gun. Press the catch plate and release the plunger rod. Push down on the plunger handle.

3.4 SUCTION FILLING

- 3.4.1 Unscrew the grease tube from the grease gun.
- 3.4.2 Ensure the handle has been released (by pressing the catch plate).
- 3.4.3 Submerge the open end of the grease tube into grease bucket by approximately 50mm (2") and slowly pull the plunger handle out fully (fig 3).
- 3.4.4 Screw the grease tube back in to the grease gun. Press the catch plate and release the plunger rod. Push down on the plunger handle.

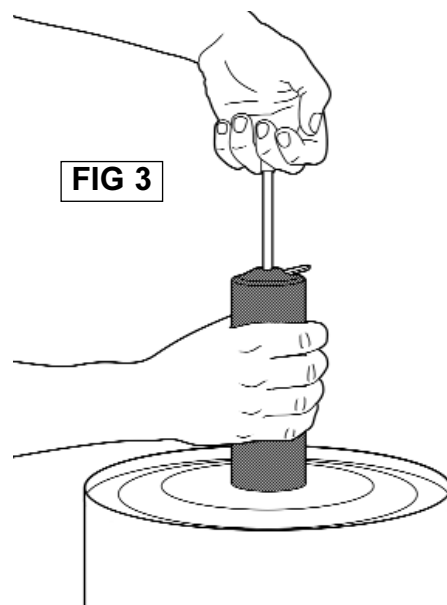

3.5 BULK FILLING

- 3.5.1 Press the catch plate to release the plunger handle.
- 3.5.2 Connect a low pressure bulk greasing unit to the bulk filler nipple at the top of the gun and fill until plunger is fully extended.
- 3.5.3 Press and hold the catch plate and push the plunger handle down until some resistance is felt.
- 3.5.4 Open the pressure release valve until grease appears.

3.6 PRIMING THE GUN

- 3.6.1 Before loading the gun with a cartridge or filling via a grease bucket, it is ideal to prime the gun.
- 3.6.2 To prime the gun simply pack grease into the cavity located at the entrance of the gun assembly (where the grease tube screws into the gun) and operate the trigger, this will induce the intake of grease into the gun assembly.

3.7 OPERATION

- 3.7.1 To operate the gun simply push the grease outlet onto the the grease nipple and operate the trigger until the desired amount of grease has been dispersed.
- 3.7.2 If you encounter air pockets during operation simply exert force on the plunger (fig 4.1), press the pressure release valve (fig 4.2) and operate trigger (fig 4.3) in short, sharp bursts until grease begins to flow from the nozzle.

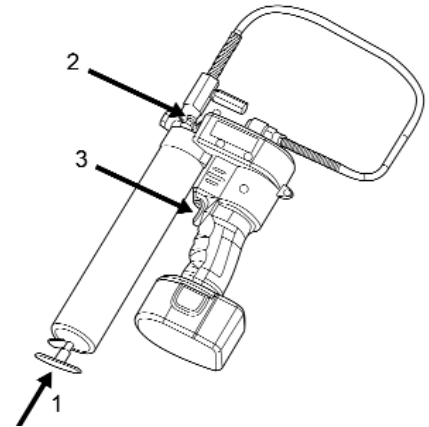

FIG 4

4. TROUBLESHOOTING

CONDITION	POSSIBLE CAUSE(S)	CORRECTIVE ACTION
Motor Fails to run.	<ul style="list-style-type: none"> - Battery needs recharging. - Faulty wiring to motor. 	<ul style="list-style-type: none"> - Recharge battery. - Remove battery, disassemble handle and check wiring for loose connections.
Pressure release valve opens to discharge grease.	<ul style="list-style-type: none"> - Blocked line. - Blocked bearing. - Blocked grease fitting. 	<ul style="list-style-type: none"> - Check lines, pipe joints and grease fittings and remove any obstructions.
Grease gun fails to dispense grease.	<ul style="list-style-type: none"> - Grease tube is out of grease. - Loss of prime. - Check valve (item 20) is not functioning. 	<ul style="list-style-type: none"> - Check that the tube contains grease. - Repeat priming operation. - Remove check valve, clean and inspect the valve seat.
Grease gun continues to lose prime.	<ul style="list-style-type: none"> - Air may be trapped in locations throughout the grease tube ass'y after bulk filling. - Grease tube follower may be binding. 	<ul style="list-style-type: none"> - Empty grease tube ass'y, refill and repeat priming operation. - Replace grease tube ass'y.
Battery fails to charge.	<ul style="list-style-type: none"> - Charger may not have power. - Battery may be dead. 	<ul style="list-style-type: none"> - Check the mains charger is providing power.

Declaration of Conformity We, the sole importer into the UK, declare that the products listed here are in conformity with the following standards and directives.

RECHARGEABLE GREASE GUN & CHARGER
Models: CPG12V & CPG12VMC
 98/37/EC Machinery Directive
 73/23/EEC Low Voltage Directive
 93/68/EEC Marking Directive
 89/336/EEC EMC Directive

The construction files for these products are held by the Manufacturer and may be inspected, by a national authority, upon request to Jack Sealey Ltd.
 Signed by Mark Sweetman 21st April 2005

For Jack Sealey Ltd.
Sole importer into the UK of Sealey Power Products.

NOTE: It is our policy to continually improve products and as such we reserve the right to alter data, specifications and component parts without prior notice. **IMPORTANT:** No liability is accepted for incorrect use of this equipment. **WARRANTY:** Guarantee is 12 months from purchase date, proof of which will be required for any claim. **INFORMATION:** For a copy of our latest catalogue and promotions call us on 01284 757525 and leave your full name and address, including postcode.

Sole UK Distributor, Sealey Group, Bury St. Edmunds, Suffolk.

01284 757500

01284 703534

www.sealey.co.uk

sales@sealey.co.uk