



# 20V 2AH CORDLESS RIVETER

MODEL NO: CP314

Thank you for purchasing a Sealey product. Manufactured to a high standard, this product will, if used according to these instructions, and properly maintained, give you years of trouble free performance.

**IMPORTANT:** PLEASE READ THESE INSTRUCTIONS CAREFULLY. NOTE THE SAFE OPERATIONAL REQUIREMENTS, WARNINGS & CAUTIONS. USE THE PRODUCT CORRECTLY AND WITH CARE FOR THE PURPOSE FOR WHICH IT IS INTENDED. FAILURE TO DO SO MAY CAUSE DAMAGE AND/OR PERSONAL INJURY AND WILL INVALIDATE THE WARRANTY. KEEP THESE INSTRUCTIONS SAFE FOR FUTURE USE.



Refer to instructions



Wear eye protection



Wear protective gloves



Wear ear protection

## 1. SAFETY

### 1.1. ELECTRICAL SAFETY

- ❑ **WARNING!** It is the user's responsibility to check the following:
  - Check all electrical equipment and appliances to ensure that they are safe before using. Inspect power supply leads, plugs and all electrical connections for wear and damage. Sealey recommend that an RCD (Residual Current Device) is used with all electrical products. You may obtain an RCD by contacting your local Sealey stockist.
  - If the used in the course of business duties, it must be maintained in a safe condition and routinely PAT (Portable Appliance Test) tested.
  - Electrical safety information, it is important that the following information is read and understood.
- ✓ Ensure that the insulation on all cables and on the appliance is safe before connecting it to the power supply.
- ✓ Regularly inspect power supply cables and plugs for wear or damage and check all connections to ensure that they are secure.
- ✓ Ensure that the voltage rating on the appliance suits the power supply to be used and that the plug is fitted with the correct fuse - see fuse rating in these instructions.
- ✗ **DO NOT** pull or carry the appliance by the power cable.
- ✗ **DO NOT** pull the plug from the socket by the cable. Remove the plug from the socket by maintaining a firm grip on the plug.
- ✗ **DO NOT** use worn or damaged cables, plugs or connectors. Ensure that any faulty item is repaired or replaced immediately by a qualified electrician.

This product is fitted with a BS1363/A 13 Amp 3 pin plug.

If the cable or plug is damaged during use, switch off the electricity supply and remove from use.

Replace a damaged plug with a BS1363/A 13 Amp 3 pin plug. If in doubt contact a qualified electrician.

Class II products are wired with live (brown) and neutral (blue) only are marked with the Class II symbol;

A) Connect the BROWN live wire to the live terminal 'L'.

B) Connect the BLUE neutral wire to the neutral terminal 'N'.

C) After wiring, check that there are no bare wires and ensure that all wires have been correctly connected.



Ensure that the cable outer sheath extends inside the cable restraint and that the restraint is tight.

- ✗ **DO NOT** connect either wire to the earth terminal.
- Sealey recommend that repairs are carried out by a qualified electrician.

### 1.2. BATTERY CHARGER SAFETY INSTRUCTIONS

- ❑ **WARNING! DO NOT** use the charging base to charge any battery other than that required for the tool. Other types of batteries may explode!
- ✓ Inspect the plug, cable and the charging base for wear and damage to ensure items are safe before connecting to the mains power supply. If worn or damaged **DO NOT** use, immediately replace, or contact a qualified electrician.
- ✓ Check cables are always protected against short circuit and overload.
- ✓ Uncoil the power cable between the plug and the charging base before use.
- ✗ **DO NOT** pull or carry the charging base by the charger power lead, or pull the plug from the mains socket by the power lead.
- ✗ **DO NOT** use any other type of transformer with the charging base.
- ✗ **DO NOT** try to open or dis-assemble the plug or charging base.
- ✗ **DO NOT** use the plug to power any other electrical item.
- ✓ Disconnect the charging base from the mains power supply when not in use.
- ✗ **DO NOT** expose the charging base to damp or wet conditions (for indoor use only).
- ✗ **DO NOT** operate the charging base if it has been dropped, or has received a sharp knock, or is damaged. Contact an authorised service agent.
- ✗ **DO NOT** dismantle the charging base as this may cause damage or personal injury and will invalidate your warranty.
- ✗ **DO NOT** insert foreign objects or material into the slot reserved for the battery.
- ✗ **DO NOT** immediately charge a second battery. Consecutive charging will overheat the charging base. Allow the unit to cool for 15 minutes before charging the next battery.
- ✓ Ensure that the insulation on all cables and on the appliance is safe before connecting it to the power supply.
- ✓ Ensure that cables are always protected against short circuit and overload.
- ✗ **DO NOT** use worn or damaged cables, plugs or connectors. Immediately have any faulty item replaced by a qualified electrician.

### 1.3. BATTERY SAFETY INSTRUCTIONS

- ❑ **WARNING!** Battery contains Lithium-ion which is dangerous. Handle with care to avoid damage, fire, corrosion or personal injury.

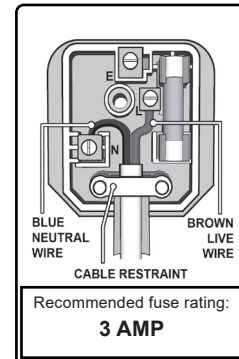

- ✓ Charge battery prior to its first use. The battery will have been shipped in a low charge state. To reduce the risk of burns or fire:
  - ✗ **DO NOT** Attempt to open, disassemble, modify or service the battery pack.
  - ✗ **DO NOT** Crush, puncture, short external contacts or dispose of in fire or water.
  - ✗ **DO NOT** Expose to temperatures above 40°C (104°F).
  - ✓ Replace only with the battery pack designated for this product.
  - ✓ Use only the charging base provided to charge the grinder battery.
  - ✗ **DO NOT** attempt recharging the battery by means of an engine generator or a DC power source.
  - ☐ **WARNING!** Dispose of spent batteries correctly as they contain Lithium-ion. **DANGER! DO NOT** attempt to disassemble the battery. For safety and environmental reasons **DO NOT** discard in domestic waste or by burning. **ONLY** discard or recycle according to local authority regulations.
  - ☐ **WARNING! DO NOT** allow a leaking battery to contact your person.
- 1.4. GENERAL SAFETY**
- ☐ **WARNING!** Ensure that Health & Safety, local authority and general workshop practice regulations are adhered to when using this equipment.
  - ✓ Familiarise yourself with the applications, limitations and potential hazards peculiar to the riveter.
  - ☐ **WARNING!** Disconnect the riveter from the battery before changing accessories, servicing or performing any maintenance.
  - ✓ Maintain the riveter in good condition (use an authorised service agent).
  - ✓ Replace or repair damaged parts. Use genuine parts only. Unauthorised parts may be dangerous and will invalidate the warranty.
  - ✓ Keep the work area clean, uncluttered and ensure that there is adequate lighting.
  - ✓ Keep the riveter clean for best and safest performance.
  - ☐ **WARNING!** Always wear approved eye or face protection when operating the riveter.
  - ✓ Maintain correct balance and footing. Ensure the floor is not slippery and wear non-slip shoes.
  - ✓ Remove ill fitting clothing. Remove ties, watches, rings and other loose jewellery and contain, and/or tie back, long hair.
  - ✓ Keep the riveter away from your body and at a safe distance from others.
  - ✓ Keep children and unauthorised persons away from the work area.
  - ✓ Secure unstable workpiece with a clamp, vice or other adequate holding device.
  - ✓ Ensure that spent rivet stems are disposed of correctly and **DO NOT** cause a hazard.
  - ✗ **DO NOT** use the riveter for any purpose other than that for which it is designed.
  - ✗ **DO NOT** operate the riveter if any parts are damaged or missing.
  - ✗ **DO NOT** get the riveter wet or use in damp or wet locations or areas where there is condensation.
  - ✗ **DO NOT** allow untrained persons to operate the riveter.
  - ✗ **DO NOT** point or fire the riveter at people or animals.
  - ✗ **DO NOT** operate the riveter when you are tired or under the influence of alcohol, drugs or intoxicating medication.
  - ✗ **DO NOT** direct air from the air hose at yourself or others.
  - ✓ When not in use disconnect from the air supply and store in a safe, dry, childproof area.

## 2. INTRODUCTION

Suitable for aluminium, steel and stainless steel rivets from 2.4 to 5.0mm. Powered by a 20V 2Ah Lithium-ion battery with a pulling force of up to 9000N. Four selectable power settings help preserve battery by only supplying the force required. LED battery level indicator. Four riveting nozzles, 2.4mm, 3.2mm, 4.0mm and 5.0mm. Supplied in durable plastic storage case with mains charger and 2Ah battery.

## 3. SPECIFICATION

**MODEL NO:**.....**CP314**  
**Battery:** .....20V 2Ah Li-ion  
**Blind Rivet Type:** .....Aluminium, Steel, Stainless Steel  
**Maximum Pulling Force:**.....9000N  
**Nozzle Size(s):**..... 2.4, 3.2, 4.0, 5.0mm  
**Replacement Parts:** ..... CP314BP - Battery Pack

## 4. OPERATION

### 4.1. BATTERY REMOVAL/ INSTALLATION

4.1.1. Always be aware of the condition of the riveter before insertion or removal of the battery cartridge.

### 4.2. BATTERY REMOVAL

4.2.1. Hold the handle tightly and push the battery latch to remove the battery.

- ☐ **WARNING!** Never short circuit the battery.

### 4.3. BATTERY INSTALLATION

4.3.1. To insert the battery cartridge, align the tongue on the battery cartridge with the groove in the housing and slip into place. Always insert it all the way until it locks in place with a little click.

**Note:** Prior to operation prepare and check the work environment, make sure the work site meets all the conditions laid out in the precautions.

### 4.4. CHECKING THE BATTERY

4.4.1. Make sure that the battery is installed firmly.

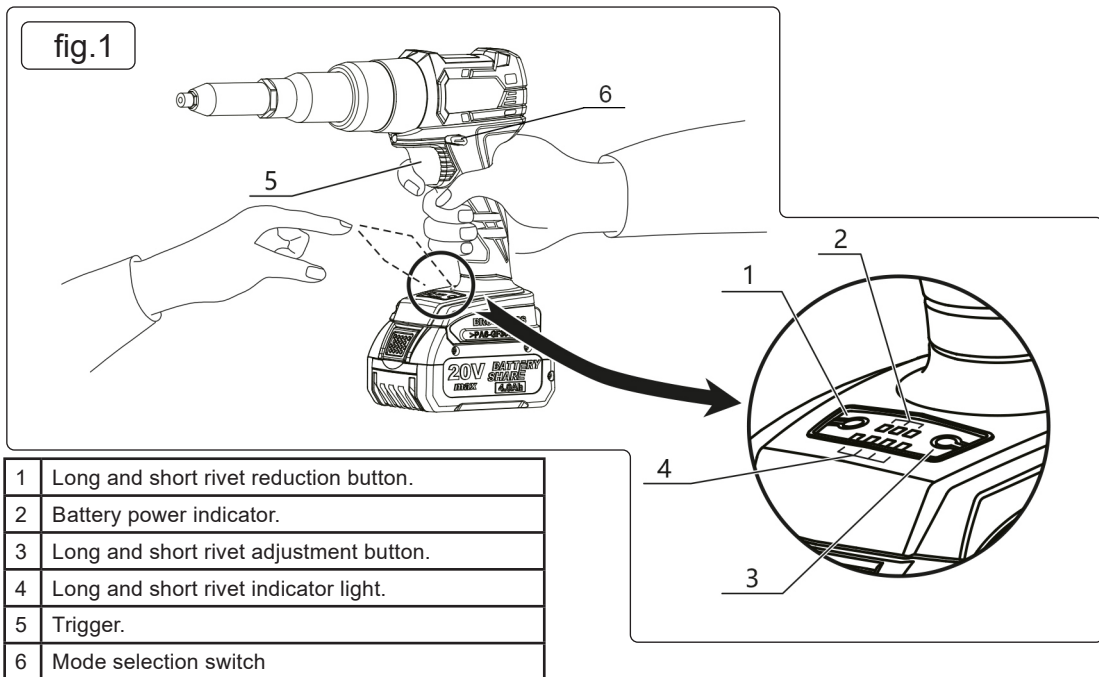

#### 4.5. USING THE RIVET GUN

4.5.1. Insert the rivet stem as far as possible into the riveter nozzle (fig.2).

#### 4.6. AUTOMATIC MODE

**NOTE:** Always use the riveter in automatic mode. To select automatic mode push the mode selection switch to the left (fig.1.6)

4.6.1. According to the size of rivet, adjust for the length of the rivet as follows;

Fig.1.1: reduce the length of rivet, which is suitable for short rivet riveting.

Fig.1.3: increase the length of rivet, which is suitable for long rivet riveting.

Fig.1.4: If one green light is on, it means the riveting mode is on for first position (shortest length for riveting); When all four lights are on it means it is set in the longest riveting position.

4.6.2. Pull the trigger to pull the rivet up. Keep the trigger depressed until the rivet stem is heard to snap away from the head (fig.2 and fig.3).

4.6.3. At this point, release the trigger; the machine will reverse automatically and release the stem.

4.6.4. When the user presses button 1 and then the trigger the riveter will be in automatic mode.

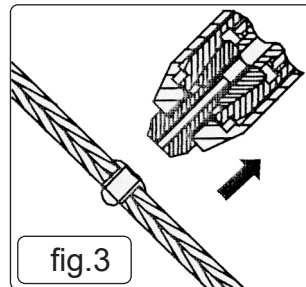
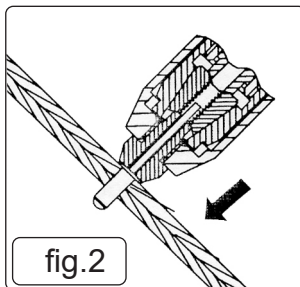

## 5. MAINTENANCE

5.1. Before using the tools, charge the battery as follows.

5.1.1. Plug the battery charger (fig.4.3). The charging light will light up green (fig.4.2).

5.1.2. Insert the battery cartridge (fig.4.1) so that the plus and minus terminals on the battery cartridge are on the same side as their respective markings on the charger.

5.1.3. When the battery cartridge is inserted fully, the charging light (fig.4.2) will flash green and charging will begin.

5.1.4. When the charging light changes to from green flashing to solid green (fig.4.2), the charging cycle is complete.

5.1.5. After charging, unplug the charger from the power source.

❑ **WARNING!** The battery charger is for the original battery cartridge. Never use it for other purposes or for other manufacturers batteries.

5.1.6. When you charge a battery cartridge which is new or has not been charged for a long period of time, it may not accept a full charge until after discharging it completely and recharging it a couple of times.

5.1.7. If you charge a battery from a just operated tool or a battery which has been exposed to direct sunlight or heat for a long time, the charging light will turn red. Let the battery cool before charging.

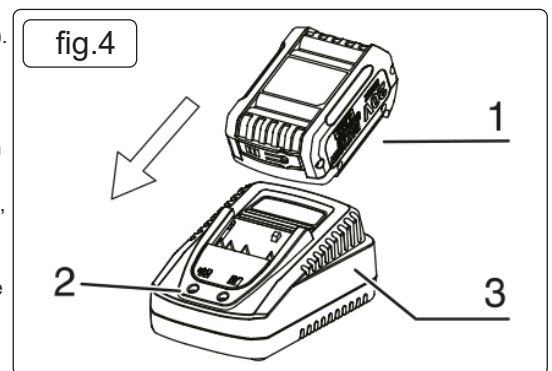

## 6. TROUBLESHOOTING

6.1. If a rivet gets stuck in the riveter, switch the riveter from automatic to manual mode a couple of times. This should free the stuck rivet.



#### ENVIRONMENT PROTECTION

Recycle unwanted materials instead of disposing of them as waste. All tools, accessories and packaging should be sorted, taken to a recycling centre and disposed of in a manner which is compatible with the environment. When the product becomes completely unserviceable and requires disposal, drain any fluids (if applicable) into approved containers and dispose of the product and fluids according to local regulations.



#### WEEE REGULATIONS

Dispose of this product at the end of its working life in compliance with the EU Directive on Waste Electrical and Electronic Equipment (WEEE). When the product is no longer required, it must be disposed of in an environmentally protective way. Contact your local solid waste authority for recycling information.



#### BATTERY REMOVAL

Under the Waste Batteries and Accumulators Regulations 2009, Jack Sealey Ltd are required to inform potential purchasers of products containing batteries (as defined within these regulations), that they are registered with Valpak's registered compliance scheme. Jack Sealey Ltd Batteries Producer Registration Number (BPRN) is BPRN00705.

**Note:** It is our policy to continually improve products and as such we reserve the right to alter data, specifications and component parts without prior notice.

**Important:** No Liability is accepted for incorrect use of this product.

**Warranty:** Guarantee is 12 months from purchase date, proof of which is required for any claim.

Sealey Group, Kempson Way, Suffolk Business Park, Bury St Edmunds, Suffolk. IP32 7AR



01284 757500



01284 703534



sales@sealey.co.uk



www.sealey.co.uk