



# 18V 1.5AH CORDLESS RIVETER

MODEL No: **CP313X**

Thank you for purchasing a Sealey product. Manufactured to a high standard, this product will, if used according to these instructions, and properly maintained, give you years of trouble free performance.

**IMPORTANT:** PLEASE READ THESE INSTRUCTIONS CAREFULLY. NOTE THE SAFE OPERATIONAL REQUIREMENTS, WARNINGS & CAUTIONS. USE THE PRODUCT CORRECTLY AND WITH CARE FOR THE PURPOSE FOR WHICH IT IS INTENDED. FAILURE TO DO SO MAY CAUSE DAMAGE AND/OR PERSONAL INJURY AND WILL INVALIDATE THE WARRANTY. KEEP THESE INSTRUCTIONS SAFE FOR FUTURE USE.



Refer to instruction manual



Wear eye protection



Wear ear protection

## 1. SAFETY

- WARNING!** Ensure that Health & Safety, local authority and general workshop practice regulations are adhered to when using this equipment.
- ✓ Familiarise yourself with the applications, limitations and potential hazards peculiar to the riveter.
- ✓ Maintain the riveter in good condition (use an authorised service agent).
- ✓ Replace or repair damaged parts. *Use genuine parts only. Unauthorised parts may be dangerous and will invalidate the warranty.*
- ✓ Keep the work area clean, uncluttered and ensure that there is adequate lighting.
- ✓ Keep the riveter clean for best and safest performance.
- WARNING!** Always wear approved eye or face protection when operating the riveter.
- ✓ Maintain correct balance and footing. Ensure the floor is not slippery and wear non-slip shoes.
- ✓ Remove ill fitting clothing. Remove ties, watches, rings and other loose jewellery and contain, and/or tie back, long hair.
- ✓ Keep the riveter away from your body and at a safe distance from others.
- ✓ Keep children and unauthorised persons away from the work area.
- ✓ Secure unstable workpiece with a clamp, vice or other adequate holding device.
- ✓ Ensure that spent rivet stems are disposed of correctly and do not cause a hazard.
- ✗ **DO NOT** use the riveter for any purpose other than that for which it is designed.
- ✗ **DO NOT** get the riveter wet or use in damp or wet locations or areas where there is condensation.
- ✗ **DO NOT** allow untrained persons to operate the riveter.
- ✗ **DO NOT** point or fire the riveter at people or animals.
- ✗ **DO NOT** operate the riveter when you are tired or under the influence of alcohol, drugs or intoxicating medication.
- ✗ **DO NOT** operate the riveter in a flammable or explosive atmosphere.

### 1.1. ELECTRICAL SAFETY

Check all electrical equipment and appliances to ensure that they are safe before using. Inspect power supply leads, plugs and all electrical connections for wear and damage. Sealey recommend that an RCD (Residual Current Device) is used with all electrical products. You may obtain an RCD by contacting your local Sealey stockist. If the product is used in the course of business duties, it must be maintained in a safe condition and routinely PAT (Portable Appliance Test) tested.

Electrical safety information, it is important that the following information is read and understood.

- 1.1.1. Ensure that the insulation on all cables and on the appliance is safe before connecting it to the power supply.
- 1.1.2. Regularly inspect power supply cables and plugs for wear or damage and check all connections to ensure that they are secure.
- 1.1.3. **Important:** Ensure that the voltage rating on the appliance suits the power supply to be used and that the plug is fitted with the correct fuse - see fuse rating in these instructions.
  - ✗ **DO NOT** pull or carry the appliance by the power cable.
  - ✗ **DO NOT** pull the plug from the socket by the cable. Remove the plug from the socket by maintaining a firm grip on the plug.
  - ✗ **DO NOT** use worn or damaged cables, plugs or connectors. Ensure that any faulty item is repaired or replaced immediately by a qualified electrician.
- 1.1.4. This product is fitted with a BS1363/A 13 Amp 3 pin plug.

If the cable or plug is damaged during use, switch the electricity supply and remove from use. Replace a damaged plug with a BS1363/A 13 Amp 3 pin plug. If in doubt contact a qualified electrician. Class II products are wired with live (brown) and neutral (blue) only are marked with the Class II symbol;

  - A) Connect the BROWN live wire to the live terminal 'L'.
  - B) Connect the BLUE neutral wire to the neutral terminal 'N'.
  - C) After wiring, check that there are no bare wires and ensure that all wires have been correctly connected.

Ensure that the cable outer sheath extends inside the cable restraint and that the restraint is tight.

  - ✗ **DO NOT** connect either wire to the earth terminal.

Sealey recommend that repairs are carried out by a qualified electrician.

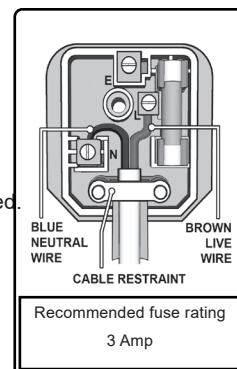

### 1.2. BATTERY CHARGER SAFETY INSTRUCTIONS

- WARNING! DO NOT** attempt to charge any battery other than that supplied for the product. Other types of batteries may explode!
- ✓ All mains electrical supply safety features must be followed as described in above.
- ✓ Disconnect the charger from the mains supply when not in use.
- ✗ **DO NOT** charge battery if room temperature is below 10°C (50°F) or above 40°C (104°F).

- × **DO NOT** expose the charger to damp or wet conditions.
- × **DO NOT** pull or carry the charger by the power lead.
- × **DO NOT** operate the charger if it has been dropped, or has received a sharp knock, or is damaged. Take the charger to an authorised agent for repair or obtain a replacement.
- × **DO NOT** dismantle the charger as this may cause damage and/or personal injury and will invalidate the warranty.
- × **DO NOT** insert foreign objects or material into the hole reserved for the battery pack.
- × **DO NOT** recharge a second battery pack immediately after charging the first. Consecutive charging will overheat the charger. Allow the unit to cool for 15 minutes before charging the next pack.
- × **DO NOT** attempt to connect two chargers together.
- ✓ Store the charger in a cool, dry place out of reach of children.

## 2. INTRODUCTION

Suitable for 2.4mm to 4.8mm aluminium rivets. Powered by an 18V 1.5Ah Lithium-ion battery with a pulling force of up to 6000N, capable of pulling up to 250 rivets on one full charge. Digital display showing battery charge level. Hardened steel jaw assembly, which returns to start position once the rivet has been secured. Supplied with four riveting nozzles, spanner, and 1 hour mains charger. Metal storage case for safe and secure storage.

## 3. SPECIFICATION

Model no .....	CP313X
Battery .....	18V 1.5Ah Li-ion
Max. pulling force .....	6000N
Nozzle sizes .....	2.4, 3.2, 4, 4.8mm
Stroke .....	21mm
Noise power .....	91dB(A)
Noise pressure .....	80dB(A)
Vibration .....	2.04m/s <sup>2</sup>
Uncertainty .....	1.5m/s <sup>2</sup>



## 4. PREPARATION

### 4.1. BATTERY CHARGING

- 4.1.1. The battery charge level may be checked at any time by pressing the red button adjacent to the charge indicator (fig.4). The level is displayed by means of a clock face indicator. Full charge is indicated by a ¾ circle.
- 4.1.2. To release the battery from the riveter, press both battery latches together and slide the battery out (fig.2).
- 4.1.3. Slide the battery into the charger (fig.3) until the catches lock in place.
- 4.1.4. Plug the charger in to the mains supply.

Low Battery	Charging	Fully Charged
Flashing Red + Green	Steady Red	Steady Green
Steady Green	Steady Green	Steady Green

- 4.1.5. To replace the battery in the riveter: slide back into the handle until the catches click.
- 4.1.6. Recharge the battery pack when necessary and after each use.
- 4.1.7. If the riveter is not used for a considerable period, recharge the battery pack every six months.
- 4.2. **NOSE PIECE SELECTION:**
- 4.2.1. The correct nose piece must be installed in the frame head for the size of rivet being used.
- 4.2.2. To remove the nose piece, turn anticlockwise using the supplied spanner (fig.5).
- 4.2.3. Replace with the appropriate nose piece for the rivet being used.
- 4.2.4. Use of an incorrect nose piece will result in the rivet stem failing to release.

## 5. OPERATION

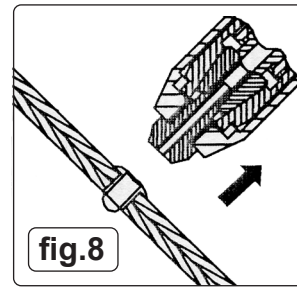
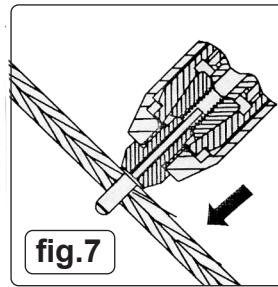
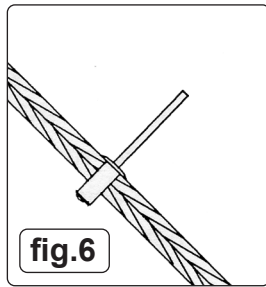
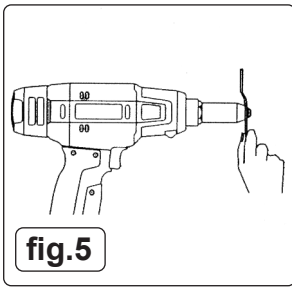

- 5.1. To insert rivets, place rivet in the pre-drilled hole (fig.6).
- 5.2. Insert the rivet stem as far as possible into the riveter nose piece (fig.7).
- 5.3. Pull the trigger to pull the rivet up. Keep the trigger depressed until the rivet stem is heard to snap away from the head (fig.8).
- 5.4. At this point, release the trigger; the machine will reverse automatically and release the stem.

## 6. MAINTENANCE

- 6.1. The head assembly will need to be stripped from time to time to clean and lubricate.
- 6.2. Before any maintenance, remove the battery to avoid accidental starting.
- 6.3. Remove the frame head by turning anticlockwise with the spanner (fig.9). This will reveal the jaw case head.
- 6.4. To remove the jaw case head, turn anticlockwise using the spanner.
- 6.5. This, in turn, will reveal the jaws, jaw pusher and spring (fig.10).
- 6.6. Clean with a suitable cleaner and, when dry, apply a little oil to the rear surfaces of the jaws.
- 6.7. Assemble in the reverse order as 6.1.1. to 6.1.4.
- 6.8. Clean the casing with a dry cloth only, do not use chemical cleaners.
- 6.9. Store in a cool, dry place out of reach of children.

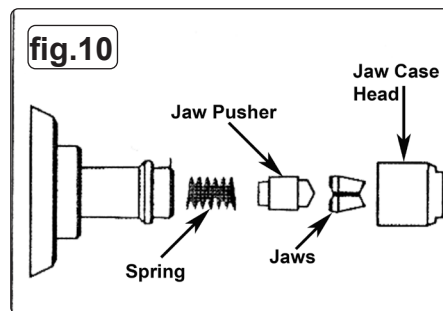
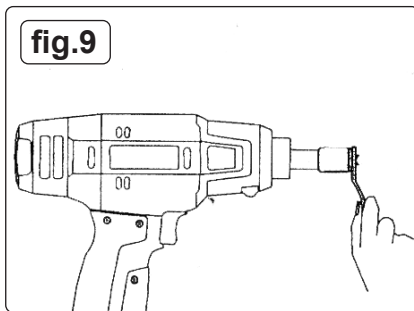

### WARNING! – Risk of Hand Arm Vibration Injury.

This tool may cause Hand Arm Vibration Syndrome if its use is not managed adequately.

This tool is subject to the vibration testing section of the Machinery Directive 2006/42/EC.

This tool is to be operated in accordance with these instructions.

**Measured vibration emission value (a): 2.04 m/s<sup>2</sup>**

**Uncertainty value (k): 1.5 m/s<sup>2</sup>**

*Please note that the application of the tool to a sole specialist task may produce a different average vibration emission. We recommend that a specific evaluation of the vibration emission is conducted prior to commencing with a specialist task.*

A health and safety assessment by the user (or employer) will need to be carried out to determine the suitable duration of use for each tool.

**NB:** Stated Vibration Emission values are type-test values and are intended to be typical.

Whilst in use, the actual value will vary considerably from and depend on many factors.

Such factors include; the operator, the task and the inserted tool or consumable.

**NB:** ensure that the length of leader hoses is sufficient to allow unrestricted use, as this also helps to reduce vibration.

*The state of maintenance of the tool itself is also an important factor, a poorly maintained tool will also increase the risk of Hand Arm Vibration Syndrome.*

#### Health surveillance.

We recommend a programme of health surveillance to detect early symptoms of vibration injury so that management procedures can be modified accordingly.

#### Personal protective equipment.

We are not aware of any personal protective equipment (PPE) that provides protection against vibration injury that may result from the uncontrolled use of this tool. We recommend a sufficient supply of clothing (including gloves) to enable the operator to remain warm and dry and maintain good blood circulation in fingers etc. Please note that the most effective protection is prevention, please refer to the Correct Use and Maintenance section in these instructions. Guidance relating to the management of hand arm vibration can be found on the HSC website [www.hse.gov.uk](http://www.hse.gov.uk) - Hand-Arm Vibration at Work.



# EC DECLARATION OF CONFORMITY

Description and Function: **Cordless Riveter 18V 1.5Ah Lithium-ion 1hr Charger**

Model/Type: **CP313X v1**

Manufacturing Date/Serial Number where applicable:

2014/30/EU EMC Directive

2014/35/EU Low Voltage Directive

2006/42/EC Machinery Directive

2011/65/EU RoHS Directive

This declaration of conformity is issued under the sole responsibility of the manufacturer:

**Jack Sealey Ltd, Kempson Way, Suffolk Business Park, Bury St Edmunds, Suffolk. IP32 7AR**

Declaration of Conformity in accordance with the above Directive(s).

References to harmonised standard(s)

EN 61000-3-2:2014

EN 61000-6-3:2007+A1:2011

EN 60335-1:2012+A11:2014+A13:2017

EN 60335-2-29:2004+A2:2010

EN 60745-1:2009+A11:2010

EN 62233:2008

Technical file compiled by: **Jack Sealey Ltd**

**Being the responsible person appointed by the manufacturer.**

Signed:

Date: 13 July 2020

Name: Steve Buckle

Position: Marketing Director

Place: Bury St Edmunds

**Sealey Group, Kempson Way, Suffolk Business Park, Bury St Edmunds, Suffolk. IP32 7AR**  
01284 757500 01284 703534 sales@sealey.co.uk www.sealey.co.uk

XVII2813



### WEEE REGULATIONS

Dispose of this product at the end of its working life in compliance with the EU Directive on Waste Electrical and Electronic Equipment (WEEE). When the product is no longer required, it must be disposed of in an environmentally protective way. Contact your local solid waste authority for recycling information.



### ENVIRONMENT PROTECTION

Recycle unwanted materials instead of disposing of them as waste. All tools, accessories and packaging should be sorted, taken to a recycling centre and disposed of in a manner which is compatible with the environment. When the product becomes completely unserviceable and requires disposal, drain any fluids (if applicable) into approved containers and dispose of the product and fluids according to local regulations.

**Note:** It is our policy to continually improve products and as such we reserve the right to alter data, specifications and component parts without prior notice.

**Important:** No Liability is accepted for incorrect use of this product.

**Warranty:** Guarantee is 12 months from purchase date, proof of which is required for any claim.

**Sealey Group, Kempson Way, Suffolk Business Park, Bury St Edmunds, Suffolk. IP32 7AR**

01284 757500 01284 703534 sales@sealey.co.uk www.sealey.co.uk