



CORDLESS JIGSAW 20V - BODY ONLY

MODEL NO: CP20VJS

Thank you for purchasing a Sealey product. Manufactured to a high standard, this product will, if used according to these instructions, and properly maintained, give you years of trouble free performance.

IMPORTANT: PLEASE READ THESE INSTRUCTIONS CAREFULLY. NOTE THE SAFE OPERATIONAL REQUIREMENTS, WARNINGS & CAUTIONS. USE THE PRODUCT CORRECTLY AND WITH CARE FOR THE PURPOSE FOR WHICH IT IS INTENDED. FAILURE TO DO SO MAY CAUSE DAMAGE AND/OR PERSONAL INJURY AND WILL INVALIDATE THE WARRANTY. KEEP THESE INSTRUCTIONS SAFE FOR FUTURE USE.



Refer to instructions



Wear eye protection



Wear protective gloves



Wear safety footwear



Wear protective clothing



Wear ear protection



Wear a mask

1. SAFETY

1.1. BATTERY CHARGER SAFETY INSTRUCTIONS

- WARNING! DO NOT** use the charging base to charge any battery other than that required for the tool. Other types of batteries may explode!
- ✓ Inspect the plug, cable and the charging base for wear and damage to ensure items are safe before connecting to the mains power supply. If worn or damaged **DO NOT** use, immediately replace, or contact a qualified electrician.
- ✓ Check cables are always protected against short circuit and overload.
- ✓ Uncoil the power cable between the plug and the charging base before use.
- ✗ **DO NOT** pull or carry the charging base by the charger power lead, or pull the plug from the mains socket by the power lead.
- ✗ **DO NOT** use any other type of transformer with the charging base.
- ✗ **DO NOT** try to open or dis-assemble the plug or charging base.
- ✗ **DO NOT** use the plug to power any other electrical item.
- ✓ Disconnect the charging base from the mains power supply when not in use.
- ✗ **DO NOT** expose the charging base to damp or wet conditions (for indoor use only).
- ✗ **DO NOT** operate the charging base if it has been dropped, or has received a sharp knock, or is damaged. Contact an authorised service agent.
- ✗ **DO NOT** dismantle the charging base as this may cause damage or personal injury and will invalidate your warranty.
- ✗ **DO NOT** insert foreign objects or material into the slot reserved for the battery.
- ✗ **DO NOT** immediately charge a second battery. Consecutive charging will overheat the charging base. Allow the unit to cool for 15 minutes before charging the next battery.
- ✓ Ensure that the insulation on all cables and on the appliance is safe before connecting it to the power supply.
- ✓ Ensure that cables are always protected against short circuit and overload.
- ✗ **DO NOT** use worn or damaged cables, plugs or connectors. Immediately have any faulty item replaced by a qualified electrician.

1.2. BATTERY SAFETY INSTRUCTIONS.

- WARNING!** Battery contains Lithium-ion which is dangerous. Handle with care to avoid damage, fire, corrosion or personal injury.
- ✓ Charge battery prior to its first use. The battery will have been shipped in a low charge state. To reduce the risk of burns or fire:
- ✗ **DO NOT** Attempt to open, disassemble, modify or service the battery pack.
- ✗ **DO NOT** Crush, puncture, short external contacts or dispose of in fire or water.
- ✗ **DO NOT** Expose to temperatures above 40°C (104°F).
- ✓ Replace only with the battery pack designated for this product.
- ✓ Use only the charging base provided to charge the grinder battery.
- ✗ **DO NOT** attempt recharging the battery by means of an engine generator or a DC power source.
- WARNING!** Dispose of spent batteries correctly as they contain Lithium-ion.
- ▲ **DANGER! DO NOT** attempt to disassemble the battery. For safety and environmental reasons **DO NOT** discard in domestic waste or by burning. ONLY discard or recycle according to local authority regulations.

1.3. GENERAL SAFETY.

- ✓ Read all safety warnings and all instructions. Failure to follow the warnings and instructions may result in electric shock, fire and/or serious injury.
- ✓ Save all warnings and instructions for future reference.
- ✓ Keep work area clean and well lit.
- ✓ Keep children and unauthorised persons away from the working area.
- ✓ Avoid body contact with earthed or grounded surfaces, such as pipes, radiators, ranges and refrigerators.
- ✓ There is an increased risk of electric shock if your body is earthed or grounded.
- ✗ **DO NOT** expose power tools to rain or wet conditions. Water entering a power tool will increase the risk of electric shock.
- ✓ Stay alert, watch what you are doing and use common sense when operating a power tool.
- ✓ Use personal protective equipment. Always wear eye protection. Protective equipment such as dust mask, non-skid safety shoes, hard hat, or hearing protection used for appropriate conditions will reduce personal injuries.
- ✓ Avoid unintentional starting.
- ✗ **DO NOT** carry the tool with your finger on the power switch.
- ✗ **DO NOT** overreach. Keep proper footing and balance at all times.
- ✓ Remove ill fitting clothing. Remove ties, watches, rings and other loose jewellery and contain long hair.

- ✓ Ensure these dust extraction and collection facilities are connected and properly used. Use of dust collection can reduce dust-related hazards.
 - ✓ Disconnect the saw from the battery unit before changing accessories, servicing or performing any maintenance.
 - ✓ Maintain the saw and battery in good condition. Check moving parts alignment on a regular basis.
 - ✓ Replace or repair damaged parts. Use an authorised service agent and recommended parts only. Unauthorised parts may be dangerous and will invalidate the warranty.
 - ✓ Ensure the saw is switched off before installing the battery pack.
 - ✓ Keep the saw and charger clean for best and safest performance.
 - ✓ Evaluate your working area before using the multi-tool e.g. ceilings, floors and enclosures may contain electrical items or water piping.
 - ✓ Ensure battery pack is correctly inserted into the tool handle and latched in place before attempting to switch it on.
 - ✓ Secure loose work pieces with a clamp, vice or other adequate holding device.
 - ✓ Wear approved safety eye protection (standard spectacles are not adequate).
 - ✓ Maintain correct balance and footing. Ensure the floor is not slippery and wear non-skid shoes.
 - ✓ Keep children and unauthorised persons away from the working area.
 - ✓ Keep tool and charger in the case and store in a safe, dry, childproof area where the temperature will not exceed 104°F (40°C).
 - ✗ **DO NOT** use the tool where there are flammable liquids, solids or gases, such as paint solvents, etc.
 - ✗ **DO NOT** allow children to operate the tool.
 - ✗ **DO NOT** operate the tool if any parts are missing as this may cause failure and/or personal injury.
 - ✗ **DO NOT** hold unsecured work piece in your hand.
 - ✗ **DO NOT** leave the tool operating unattended.
 - ✗ **DO NOT** use the tool for a task it is not designed to perform.
 - ✗ **DO NOT** operate the tool when you are tired or under the influence of alcohol, drugs or intoxicating medication.
 - ✗ **DO NOT** get the tool or battery charger wet or use in damp or wet locations.
- 1.4. POWER TOOL USE AND CARE**
- ✗ **DO NOT** force the power tool. Use the correct power tool for your application. The correct power tool will do the job better and safer at the rate for which it was designed.
 - ✗ **DO NOT** use the power tool if the switch does not turn it on and off. Any power tool that cannot be controlled with the switch is dangerous and must be repaired.
 - ✓ Disconnect the plug from the battery pack from the power tool before making any adjustments, changing accessories, or storing power tools. Such preventive safety measures reduce the risk of starting the power tool accidentally.
 - ✓ Store idle power tools out of the reach of children.
 - ✗ **DO NOT** allow persons unfamiliar with the power tool or these instructions to operate the power tool. Power tools are dangerous in the hands of untrained users.
 - ✓ Maintain power tools. Check for misalignment or binding of moving parts, breakage of parts and any other condition that may affect the power tool's operation. If damaged, have the power tool repaired before use.
 - ✓ Keep cutting tools sharp and clean. Properly maintained cutting tools with sharp cutting edges are less likely to bind and are easier to control.
 - ✓ Use the power tool, accessories and tool bits etc. in accordance with these instructions, taking into account the working conditions and the work to be performed.
 - ✓ Use of the power tool for operations different from those intended could result in a hazardous situation.

2. INTRODUCTION

Powerful, lightweight cordless jigsaw suitable for cutting wood, board, plastic and steel. Comfortable composite housing with soft grip for added comfort. Tool-free blade change system. Variable speed control trigger switch 0-2400spm. Features dust blow and extraction function, and parallel guide. Built-in LED work light. Four pendulum settings. 2-Stage operation switch for added safety. Supplied with hex key and wood cutting blade. Requires compatible 20V battery and mains charger, sold separately.

3. SPECIFICATION

Model No:CP20VJS
 Battery: 20V 2Ah - 6Ah Lithium-ion (not included)
 Consumable parts:
 CP20VBP2 - 2Ah Battery
 CP20VBP4 - 4Ah Battery
 CP20VBP6 - 6Ah Battery
 Cutting specification:
 Wood: 80mm
 Plastic: 12mm
 Steel: 10mm
 Metal pipe: Ø5-25mm
 No Load Speed: 0-2400spm
 Replacement parts:
 CP20VMC - Mains Charger (not included)
 Stroke Length: 25mm
 Noise power/pressure: 90/79db(A)
 Vibration/uncertainty: 11.18/1.5m/s²

4. FEATURES

Number	Description
1	On/Off Trigger
2	Safety Buttons
3	Pendulum Adjustment Knob
4	Blade Holder
5	Blade Guard
6	Lock Screw For Parallel Guide
7	Saw Blade
8	Parallel Guide
9	Saw Blade Wheel
10	Sole plate
11	Dust Extraction Nozzle

5. OPERATION

5.1. INSERTING AND REMOVING THE BATTERY

- **WARNING!** Check that the jig saw is off.
- 5.1.1. Insert the battery's ridges into the grooves on the jig saw and push the battery until it clicks into place.
- 5.1.2. Press the release button and pull the battery to remove it from the jig saw.

5.2. PREPARATION AND ADJUSTMENT

- 5.2.1. Adjusting the parallel guide
- 5.2.2. Set the parallel guide (fig.1.8) at the required distance from the saw blade and tighten using the lock screws (fig.1.6).

5.3. SETTING THE BEVEL ANGLE

- 5.3.1. Loosen the bevel adjusting screw (fig.2) under the jig saw. Push the sole-plate back to adjust the bevel angle to one of the fixed settings of 0, 15, 30 or 45 degrees and re-tighten the bevel adjustment screw.
- 5.3.2. To set the bevel angle to a different angle, instead push the sole-plate forwards, tilt it to the desired angle from 0.47 degrees and re-tighten the bevel adjustment screw.

5.4. VACUUM EXTRACTOR NOZZLE

- 5.4.1. Attach a vacuum collector or dust extraction, to the dust extraction nozzle (fig.1.11) on the jig saw.

NOTE: That is not possible to attach a vacuum collector or dust extraction when sawing mitres.

5.5. REPLACING SAW BLADES

- 5.5.1. Remove the battery from the jig saw. Press the blade holder (fig.1.4) up and pull the old blade out of the holder.

5.6. SAWING

- 5.6.1. To switch on the jig saw, press the safety button (fig.1.2) and the on/off trigger (fig.1.1) simultaneously.
- 5.6.2. The work light comes on and the saw blade (fig.1.7) moves up and down.
- 5.6.3. The longer the on/off button is pressed in, the quicker the saw blade moves.
- 5.6.4. Release the on/off button to stop the saw.
- 5.6.5. Push a new saw blade as far as possible into the groove in the blade holder with the teeth facing forward and with the back edge against the saw blade wheel (fig.1.9).
- 5.6.6. Release the blade holder so that it glides back into its original position. If necessary, pull down on it.
- 5.6.7. Pull the saw blade to check that it is correctly positioned and locked in place.
- 5.6.8. Replace the battery in the jig saw.

5.7. ADJUSTING THE PENDULUM REGULATOR

- 5.7.1. The saw blade pendulum has 4 settings (0, I, II, III) which can be selected using the pendulum adjustment knob (fig.1.3).
- 5.7.2. The pendulum setting adapts the quality of cut to the material being worked by changing the movement pattern of the blade in relation to the workpiece. The higher the setting, the more aggressive the cut.
- 5.7.3. Use a low pendulum setting or switch the function off if a very fine cut is required. At a setting of 0, the blade moves vertically up and down.
- 5.7.4. Always switch off the pendulum adjustment when working in metal, hardwood or thin material, such as sheet metal.
- 5.7.5. Use a low setting if working on hard materials.
- 5.7.6. Use the maximum setting when working on soft materials and when sawing with the grain.

5.8. ABOUT SAWING

- 5.8.1. Never use a blade unsuitable for the and item to be cut.

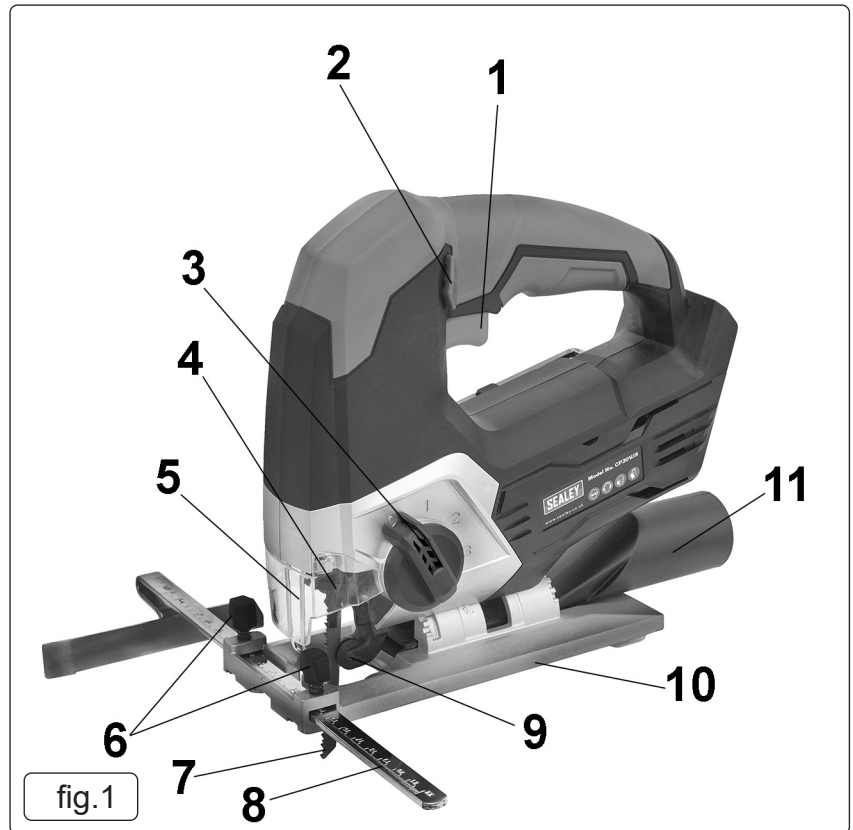

fig.1

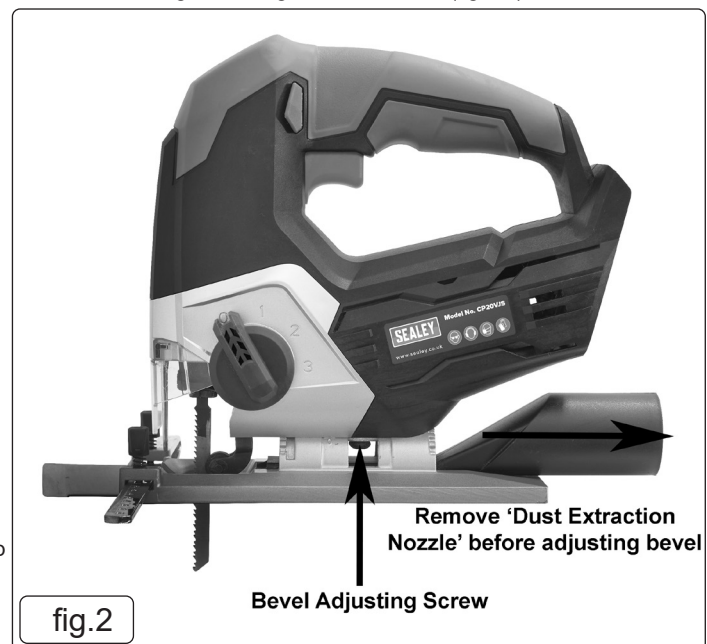

fig.2

Bevel Adjusting Screw

Remove 'Dust Extraction Nozzle' before adjusting bevel

- 5.8.2. Hold the saw in front of you with a firm grip on the handle.
- 5.8.3. Ensure that the saw blade is not touching anything and that the power cable is not in the way when starting the saw.
- 5.8.4. Make sure that the workpiece is clamped tight, and that the saw line is clearly marked.
- 5.8.5. Start the jig saw. Place the sole-plate on the item, and let the sawblade touch the saw line.
 - * **DO NOT** place more pressure on the blade than is necessary. Avoid lateral pressure on the blade.
- 5.8.6. To create a notch, drill a hole of an appropriate diameter and use this as the starting point for sawing.
- 5.9. SAWING WOOD**
- 5.9.1. Check that the item does not contain nails or other materials.
- 5.10. SAWING METAL**
- 5.10.1. We recommend lubricating the material and saw blade with cutting oil to protect the tool and avoid overheating. Support the item with wooden blocks on either side.
- 5.11. SAWING MASONRY**
- 5.11.1. Harmful dust can be created by cutting certain materials. Always wear a mask.

6. MAINTENANCE

- WARNING!** To prevent injury from accidental operation, turn the On/Off switch of the tool off and remove battery before performing any inspection, maintenance or cleaning procedures.
- WARNING!** To prevent serious injury from tool failure, **DO NOT** use damaged equipment. If abnormal noise or vibration occurs, have the problem corrected before further use.
- 6.1.** Before each use, inspect the general condition of the tool. Check for loose screws, misalignment or binding of moving parts, cracked or broken parts, damaged electrical wiring, and any other condition that may affect its safe operation.
- 6.2.** After use clean external surfaces with a clean cloth.

WARNING! – Risk of Hand Arm Vibration Injury.

This tool may cause Hand Arm Vibration Syndrome if its use is not managed adequately.
 This tool is subject to the vibration testing section of the Machinery Directive 2006/42/EC.
 This tool is to be operated in accordance with these instructions.

Measured vibration emission value (a).....11.18m/s²
 Uncertainty value (k):.....1.5m/s²

Please note that the application of the tool to a sole specialist task may produce a different average vibration emission. We recommend that a specific evaluation of the vibration emission is conducted prior to commencing with a specialist task.

A health and safety assessment by the user (or employer) will need to be carried out to determine the suitable duration of use for each tool.

NB: Stated Vibration Emission values are type-test values and are intended to be typical.

Whilst in use, the actual value will vary considerably from and depend on many factors.

Such factors include; the operator, the task and the inserted tool or consumable.

NB: ensure that the length of leader hoses is sufficient to allow unrestricted use, as this also helps to reduce vibration.

The state of maintenance of the tool itself is also an important factor, a poorly maintained tool will also increase the risk of Hand Arm Vibration Syndrome.

Health surveillance.

We recommend a programme of health surveillance to detect early symptoms of vibration injury so that management procedures can be modified accordingly.

Personal protective equipment.

We are not aware of any personal protective equipment (PPE) that provides protection against vibration injury that may result from the uncontrolled use of this tool. We recommend a sufficient supply of clothing (including gloves) to enable the operator to remain warm and dry and maintain good blood circulation in fingers etc. Please note that the most effective protection is prevention, please refer to the Correct Use and Maintenance section in these instructions. Guidance relating to the management of hand arm vibration can be found on the HSC website www.hse.gov.uk - Hand-Arm Vibration at Work.



WEEE REGULATIONS

Dispose of this product at the end of its working life in compliance with the EU Directive on Waste Electrical and Electronic Equipment (WEEE). When the product is no longer required, it must be disposed of in an environmentally protective way. Contact your local solid waste authority for recycling information.



ENVIRONMENT PROTECTION

Recycle unwanted materials instead of disposing of them as waste. All tools, accessories and packaging should be sorted, taken to a recycling centre and disposed of in a manner which is compatible with the environment. When the product becomes completely unserviceable and requires disposal, drain any fluids (if applicable) into approved containers and dispose of the product and fluids according to local regulations.

Note: It is our policy to continually improve products and as such we reserve the right to alter data, specifications and component parts without prior notice.

Important: No Liability is accepted for incorrect use of this product.

Warranty: Guarantee is 12 months from purchase date, proof of which is required for any claim.

Sealey Group, Kempson Way, Suffolk Business Park, Bury St Edmunds, Suffolk. IP32 7AR



01284 757500



01284 703534



sales@sealey.co.uk



www.sealey.co.uk