

Thank you for purchasing a Sealey product. Manufactured to a high standard this product will, if used according to these instructions and properly maintained, give you years of trouble free performance.



IMPORTANT: PLEASE READ THESE INSTRUCTIONS CAREFULLY. NOTE THE SAFE OPERATIONAL REQUIREMENTS, WARNINGS, AND CAUTIONS. USE THIS PRODUCT CORRECTLY, AND WITH CARE FOR THE PURPOSE FOR WHICH IT IS INTENDED. FAILURE TO DO SO MAY CAUSE DAMAGE AND/OR PERSONAL INJURY AND WILL INVALIDATE THE WARRANTY.

1. SAFETY INSTRUCTIONS

1.1. GENERAL SAFETY.

- ✓ Disconnect the drill from the battery unit before changing accessories, servicing or performing any maintenance.
- ✓ Maintain the drill and battery in good condition. Check moving parts alignment on a regular basis.
- ✓ Replace or repair damaged parts. *Use an authorised service agent and recommended parts only. Unauthorised parts may be dangerous and will invalidate the warranty.*
- ✓ Ensure the drill is switched off before installing the battery pack.
- ✓ Keep the drill and charger clean for best and safest performance.
- ✓ Remove ill fitting clothing. Remove ties, watches, rings and other loose jewellery and contain long hair.
- ✓ Evaluate your working area before using the drill e.g. ceilings, floors and enclosures may contain electrical items or water piping.
- ✓ Ensure battery pack is correctly inserted into the drill handle and latched in place before attempting to switch on drill.
- ✓ Secure loose work pieces with a clamp, vice or other adequate holding device.
- ✓ Avoid unintentional starting.
- ✓ Wear approved safety eye protection (standard spectacles are not adequate).
- ✓ Maintain correct balance and footing. Ensure the floor is not slippery and wear non-skid shoes.
- ✓ Be aware that this drill does not need to be plugged into the mains power.
- ✓ Keep chuck direction switch in the locked position until the drill is required for use.
- ✓ Keep children and unauthorised persons away from the working area.
- ✗ **DO NOT** use the drill where there are flammable liquids, solids or gases, such as paint solvents, etc.
- ✗ **DO NOT** allow children to operate the drill.
- ✗ **DO NOT** operate the drill if any parts are missing as this may cause failure and/or personal injury.
- ✗ **DO NOT** hold unsecured work piece in your hand.
- ✗ **DO NOT** leave the drill operating unattended.
- ✗ **DO NOT** carry the drill with your finger on the power switch. Keep chuck direction switch in the locked position.
- ✗ **DO NOT** use the drill for a task it is not designed to perform.
- ✗ **DO NOT** operate the drill when you are tired or under the influence of alcohol, drugs or intoxicating medication.
- ✗ **DO NOT** get the drill or battery charger wet or use in damp or wet locations.
- ✓ Keep drill and charger in the case and store in a safe, dry, childproof area where the temperature will not exceed 104°F (40°C).

1.2. BATTERY SAFETY.

- WARNING! Battery contains nickel-cadmium which is dangerous. Handle with care to avoid damage, fire, corrosion or personal injury.**
- ✓ Charge battery prior to first use. The battery pack will have been shipped in a low charge state.
- ✓ Use only the charger provided to charge the drill battery.
- ✗ **DO NOT** charge battery when room temperature is below 50°F (10°C) or above 104°F (40°C).
- ✗ **DO NOT** attempt recharging the battery by means of an engine generator or a DC power source.
- ✗ **DO NOT** short-circuit the battery by linking both terminals with a metal object, or your fingers etc.
- ✗ **DO NOT** store the battery (or drill) in locations where the temperature may exceed 104°F (40°C) such as outside sheds, above heaters, or metal buildings in summer.
- WARNING! Dispose of spent batteries correctly.**
DANGER! DO NOT attempt to disassemble the battery pack. For safety and environmental reasons DO NOT discard in domestic waste or by burning. ONLY discard or recycle according to local authority regulations.
- WARNING! DO NOT allow a leaking battery to contact your person. If you come into contact with battery liquid take the following immediate action:**
 - a) **Skin contact:** Wash immediately with soap and water, then wash flesh in either lemon juice or vinegar.
 - b) **Eye contact:** Wash with a strong solution of boric acid, and seek immediate medical attention.

1.3. ELECTRICAL SAFETY.

- WARNING! It is the owner's responsibility to read, understand and comply with the following electrical instructions:**
You must ensure the risk of electric shock is minimised by the installation of appropriate safety devices. An RCCB (Residual Current Circuit Breaker) should be incorporated in the main distribution board. We also recommend that an RCD (Residual Current Device) is used with all electrical products, particularly portable equipment which is plugged into an electrical supply not protected by an RCCB. **You must** also read and understand the following instructions concerning electrical safety.
- 1.3.1. The **Electricity At Work Act 1989** requires all portable electrical appliances, if used on business premises, to be tested by a qualified electrician, using a Portable Appliance Tester (PAT), at least once a year.
- 1.3.2. The **Health & Safety at Work Act 1974** makes owners of electrical appliances responsible for the safe condition of the appliance and the safety of the appliance operator.
If in any doubt about electrical safety, contact a qualified electrician.

- ✓ Ensure that the charger and cable are inspected for wear and damage, to ensure they are safe before connecting to the mains power supply. If worn or damaged **DO NOT** use, immediately replace or contact a qualified electrician.
- ✓ Check cables are always protected against short circuit and overload.
- ✓ **Important:** Check that the voltage marked on the charger is the same as the power supply to be used.
- ✗ **DO NOT** pull or carry the charger by the power lead, or pull the plug from the mains socket by the power lead.
- ✗ **DO NOT** use any other type of charger.
- ✗ **DO NOT** try to open or disassemble the charger.
- ✗ **DO NOT** get the charger wet, or use in wet, damp conditions (for indoor use only).
- 1.4. **BATTERY CHARGER SAFETY INSTRUCTIONS.**
- **WARNING! DO NOT use the charger to charge any battery other than that supplied for the drill. Other types of batteries may explode!**
- ✓ All mains electrical supply safety features must be followed as described in 1.3. above.
- ✓ Disconnect the charger from the mains power supply when not in use.
- ✗ **DO NOT** operate the charger if it has been dropped, or has received a sharp knock, or is damaged. Contact an authorised service agent.
- ✗ **DO NOT** insert foreign objects or material into the hole reserved for the battery.
- ✗ **DO NOT** force the battery into the charger. The battery will only fit one way to ensure correct polarity alignment.
- ✗ **DO NOT** immediately charge a second battery. Consecutive charging will overheat the charger. Allow the unit to cool for 15 minutes before charging the next battery.
- ✗ **DO NOT** attempt to connect two chargers together.
- ✓ Store the charger in the same manner as battery, see section 1.2.

2. INTRODUCTION & SPECIFICATION

Superbly balanced tool, intended for professional use. Features sixteen position torque control plus hammer action. Electronic variable speed control with reverse. 10mm keyless chuck. LCD display indicates battery level. Ideal for both screw driving and drilling. 1hr Charger with Schuko plug. Supplied in carry-case together with two batteries and accessories.

Variable Speeds: 0-350/0-900rpm
 Chuck Size: 10mm
 Impact Rate: 0-8000bpm
 Weight Including Battery: 1.79kg
 Battery Model No.: CB1801VBPV3
 Drilling Capacities:
 Wood: 10mm
 Metal: 6mm

Accessories:
 Magnetic Bit Holder
 Drills: 1.5, 2.5, 3, 4, 5, 6mm
 Screwdriver Bits: Slotted 5, 6mm
 Phillips #1, #2
 Pozi #1, #2

3. OPERATING INSTRUCTIONS

Note: When new, the battery may have been shipped in a low charge state. It will take longer to charge the battery initially and several subsequent charges may also take a little longer, than when the battery reaches its optimum performance.

3.1. CHARGING THE BATTERY PACK

- 3.1.1. To remove the battery pack from the drill, depress the two side clips on the battery. Do not touch the metal battery terminals.
- 3.1.2. Place the charger on a safe flat surface and connect to the mains.
- 3.1.3. The battery is designed to fit into the charger one way only. This is to ensure that the positive (+) and negative (-) polarities correspond. Align the + and - polarity marks on the base of the battery with the + and - marks on the charger, insert the battery and press lightly to seat the battery firmly into the charger (fig.2).
- WARNING! DO NOT try to force battery into the charger with crossed polarities.**
- 3.1.4. The green charge light will come on when the battery is inserted into the charger. Press the "SET" button to initiate charging, the red light will now illuminate.
- 3.1.5. When charging is complete the green light will illuminate. Remove the battery from the charger. Unplug the charger from the mains. Refit the battery into the drill base until it latches into place. The drill is now ready for use.

Note: Attempting to recharge a battery *immediately* after use may result in the red charge light not coming on. In such a case allow the battery to cool for a time and try again.

3.2. USING THE DRILL

(Ensure that you have read, understood and comply with all the safety instructions in Section 1)

WARNING! Always wear approved safety glasses when drilling.

- 3.2.1. Ensure the direction switch is in the mid (lock) position. Open the chuck by holding the rear collar (fig.3.B) and turning the front chuck collar (fig.3.A).
- 3.2.2. Insert the required drill or screwdriver bit fully into the chuck and tighten chuck.
- 3.2.3. The speed of the drill is controlled by the variable power trigger. After moving the direction switch to 'forward' or 'reverse' as appropriate, squeeze the power trigger gently for a slow speed and progressively increase the pressure on the trigger to produce correspondingly higher speeds.
- 3.2.4. To select torque or drill setting, twist the torque selector (fig.3.D) to the required setting - from 1 (the lowest) to 16 (the highest) for torque setting or to the drill symbol for drilling.

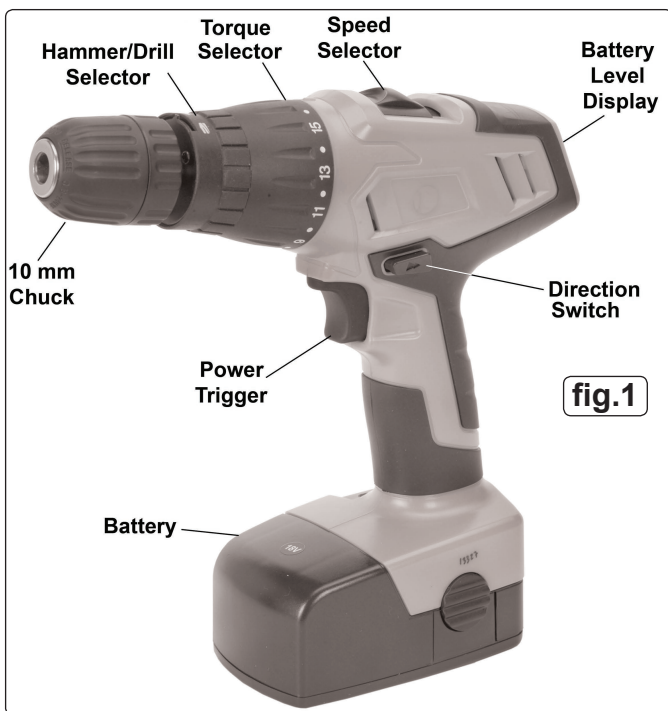

fig.1

- 3.2.5. To select 'hammer action' if required for drilling, turn the selector (fig.3.C) counter-clockwise aligning the hammer symbol with the torque setting arrow on the main body. Turn the selector clockwise to return to the normal drill setting.
- 3.2.6. There are 2 speeds controlled by the speed selector on top of the drill:
 - 1 - slower speed - 0-350rpm
 - 2 - higher speed - 0-900rpm
 Select the appropriate speed as required.
- 3.2.7. Drilling.

Insert a pilot drill bit (a smaller sized drill than the required finished hole size) into the chuck and lock in position. Check to confirm the rotational direction is correct (*DO NOT attempt to change direction whilst the drill is running*).

After drilling the initial pilot hole, insert the final sized drill bit and drill out the hole to the appropriate size.

If the drill becomes stuck, release the trigger and place the drill in reverse and try running the drill slowly whilst moving the drill out of the hole. If this does not work, gently work the drill bit free. If the chuck stops turning, check the torque setting.
- 3.2.8. To check the condition of the battery, press and hold the battery indicator button next to the battery level indicator at the rear of the drill.
- 3.2.9. When finished working, remove the bit from the chuck, clean drill and bit, and store in the case.



fig.2

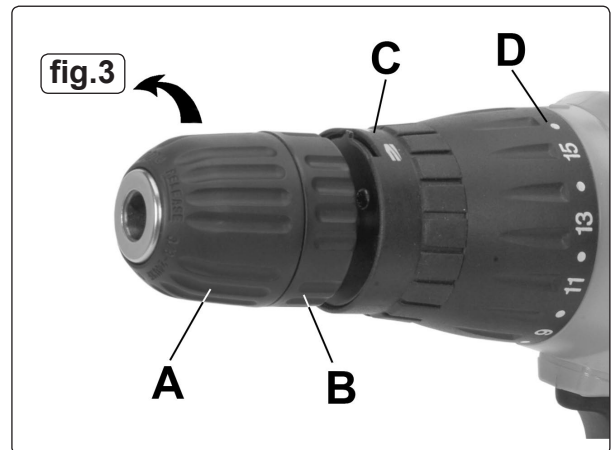

fig.3

Risk of Hand-Arm Vibration Injury.

Cordless 2-Speed Hammer Drill/Driver: CP1801VEU when operated in accordance with these instructions and tested in accordance with BS EN 28662-1:1993, ISO 8662-1:1988 and BS EN ISO 8662-6:1995, ISO 8662-6:1994 results in the following vibration emission declared in accordance with BS EN 12096:1996.

Measured vibration emission value: **0.46m/s²**
 Uncertainty value: **0.18m/s²**

These values are suitable for comparison with emission levels of other tools that have been subject to the same test. This tool may cause hand-arm vibration syndrome if its use is inadequately managed.

Recommended Measures to reduce risk of hand-arm vibration syndrome:

This item represents a low Hand Arm Vibration risk to users. The calculated maximum usage period exceeds 8 hours. We recommend appropriate safety equipment is utilised and regular breaks for the operator are employed to reduce any residual risk of fatigue or repetitive strain injury.



Environmental Protection.
 Recycle unwanted materials instead of disposing of them as waste. All tools, accessories and packaging should be sorted, taken to a recycle centre and disposed of in a manner which is compatible with the environment.



When the product is no longer required, it must be disposed of in an environmentally protective way.

Battery Removal

Remove the battery pack - see section 3.1.1. Dispose of spent battery pack correctly. ONLY dispose of or recycle according to local authority regulations.



Ni-Cd

Under the Waste Batteries and Accumulators Regulations 2009, Jack Sealey Ltd are required to inform potential purchasers of products containing batteries (as defined within these regulations), that they are registered with Valpak's registered compliance scheme. Jack Sealey Ltd's Batteries Producer Registration Number (BPRN) is BPRN00705

NOTE: It is our policy to continually improve products and as such we reserve the right to alter data, specifications and component parts without prior notice.

IMPORTANT: No liability is accepted for incorrect use of this product.

WARRANTY: Guarantee is 12 months from purchase date, proof of which will be required for any claim.

INFORMATION: For a copy of our latest catalogue and promotions call us on 01284 757525 and leave your full name and address, including postcode.



Sole UK Distributor, Sealey Group,
 Kempson Way, Suffolk Business
 Park, Bury St. Edmunds, Suffolk,
 IP32 7AR



01284 757500



www.sealey.co.uk



01284 703534



sales@sealey.co.uk