



Instructions for:  
**CORDLESS DRILL / DRIVER**  
Model: **CP12V**

Thank you for purchasing a Sealey product. Manufactured to a high standard this product will, if used according to these instructions and properly maintained, give you years of trouble free performance.



**IMPORTANT: PLEASE READ THESE INSTRUCTIONS CAREFULLY. NOTE THE SAFE OPERATIONAL REQUIREMENTS, WARNINGS & CAUTIONS. USE THE PRODUCT CORRECTLY AND WITH CARE FOR THE PURPOSE FOR WHICH IT IS INTENDED. FAILURE TO DO SO MAY CAUSE DAMAGE OR PERSONAL INJURY AND WILL INVALIDATE THE WARRANTY. PLEASE KEEP INSTRUCTIONS SAFE FOR FUTURE USE.**

## 1. SAFETY INSTRUCTIONS

### 1.1. GENERAL SAFETY

- ✓ Disconnect the drill from the battery unit before changing accessories, servicing or performing any maintenance.
- ✓ Maintain the drill and battery in good condition. Check moving parts alignment on a regular basis.
- ✓ Replace or repair damaged parts. *Use an authorised service agent and recommended parts only. Non-authorised parts may be dangerous and will invalidate the warranty.*
- ✓ Ensure the drill is switched off before installing the battery pack.
- ✓ Keep the drill and charging base clean for best and safest performance.
- ✓ Remove ill fitting clothing. Remove ties, watches, rings and other loose jewellery and contain long hair.
- ✓ Use in adequate working area for its function. Keep area clean, tidy and free from unrelated materials. Ensure there is adequate lighting.
- ✓ Evaluate your working area before using the drill e.g. ceiling, floors and enclosures may contain electrical items or water piping.
- ✓ Ensure battery pack is correctly inserted into the drill handle and latched in place before attempting to switch on drill.
- ✓ Secure loose work pieces with a clamp, vice or other adequate holding device.
- ✓ Avoid unintentional starting.
- ✓ Wear approved safety eye protection (standard spectacles are not adequate).
- ✓ Maintain correct balance and footing. Ensure the floor is not slippery and wear non-skid shoes.
- ✓ Be aware that this drill does not need to be plugged into the mains power.
- ✓ Keep chuck direction switch in the locked position until the drill is required for use.
- ✓ Keep children and unauthorised persons away from the working area.
- x DO NOT use the drill where there are flammable liquids, solids or gases, such as paint solvents, etc.
- x DO NOT allow children to operate the drill.
- x DO NOT operate the drill if any parts are missing as this may cause failure or possible personal injury.
- x DO NOT hold unsecured work piece in your hand.
- x DO NOT leave the drill operating whilst unattended.
- x DO NOT carry the drill with your finger on the power switch. Keep chuck direction switch in the locked position.
- x DO NOT force the drill to achieve a task it was not designed to perform.
- x DO NOT operate the drill when you are tired, under the influence of alcohol, drugs or intoxicating medication.
- x DO NOT get the drill or battery charger wet or use in damp or wet locations.
- ✓ Keep drill and charger in the case and store in a safe, dry, childproof area where the temperature will not exceed 104°F (40°C).

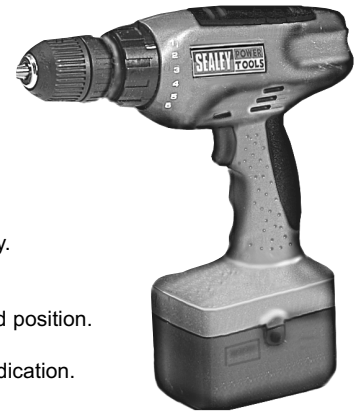

### 1.2. BATTERY SAFETY INSTRUCTIONS.

- WARNING!** Battery contains nickel-cadmium which is dangerous. Handle with care to avoid damage, fire, corrosion or personal injury.
- ✓ Charge battery prior to its first use. The battery pack will have been shipped in a low charge state.
- ✓ Use only the charging base provided to charge the drill battery.
- x DO NOT charge battery when room temperature is below 50°F (10°C) or above 104°F (40°C).
- x DO NOT attempt recharging the battery by means of an engine generator or a DC power source.
- x DO NOT short-circuit the battery by linking both terminals with a metal object, or your fingers etc.
- x DO NOT store the battery (or drill) in locations where the temperature may exceed 104°F (40°C) such as outside sheds, above heaters, or metal buildings in summer.
- WARNING!** dispose of spent batteries correctly as they contain nickel-cadmium. **DANGER!** DO NOT attempt to disassemble the battery pack. For safety and environmental reasons DO NOT discard in domestic waste or by burning. ONLY discard or recycle according to local authority regulations.
- WARNING!** DO NOT allow a leaking battery to contact your person. If you come into contact with battery liquid take the following immediate action:
  - a) **Skin contact:** Wash immediately with soap and water, then wash flesh in either lemon juice or vinegar.
  - b) **Eye contact:** Wash with a strong solution of boric acid, and seek immediate medical attention.

### 1.3. ELECTRICAL SAFETY.

#### REGARDING DIRECT MAINS POWER USE WITH THE CHARGING BASE AND TRANSFORMER PLUG ONLY.

**WARNING!** It is the user's responsibility to read, understand and comply with the following electrical instructions: You must ensure the risk of electric shock is minimised by the installation of appropriate safety devices. An RCCB (Residual Current Circuit Breaker) should be incorporated in the main distribution board. We also recommend that an RCD (Residual Current Device) is used with all electrical products, particularly portable equipment which is plugged into an electrical supply not protected by an RCCB.

**You must** also read and understand the following instructions concerning electrical safety.

- 1.3.1. **The Electricity At Work Act 1989** requires all portable electrical appliances, if used on business premises, to be tested by a qualified electrician, using a Portable Appliance Tester (PAT), at least once a year.
- 1.3.2. **The Health & Safety at Work Act 1974** makes owners of electrical appliances responsible for the safe condition of the appliance, and the safety of the appliance operator. **If in any doubt about electrical safety, contact a qualified electrician.**
- 1.3.3. **You must ensure that you:**
  - ✓ Inspect the transformer plug, cable, adaptor and the charging base for wear and damage to ensure items are safe before connecting to the mains power supply. If worn or damaged DO NOT use, immediately replace, or contact a qualified electrician.
  - ✓ Check cables are always protected against short circuit and overload.

- ✓ Important: Check that the voltage marked on the transformer plug is the same as the power supply to be used.
- ✓ Uncoil the power cable between the transformer and the charging base before use.
- ✗ DO NOT pull or carry the charging base by the transformer power lead, or pull the transformer plug from the mains socket by the power lead.
- ✗ DO NOT use any other type of transformer with the charging base.
- ✗ DO NOT place the power connector into any area of charging base except the correct socket (beneath the green power light bulb).
- ✗ DO NOT try to open or dis-assemble the transformer plug or charging base.
- ✗ DO NOT use the transformer plug to power any other electrical item.
- ✗ DO NOT get the transformer wet, or use in wet, damp conditions (for indoor use only).
- ☐ **WARNING!** NEVER substitute a standard 13Amp 3 pin plug, or any other type of plug, for the transformer plug .

#### 1.4. BATTERY CHARGING BASE SAFETY INSTRUCTIONS.

- ☐ **WARNING!** DO NOT use the charging base to charge any battery other than that supplied for the drill. Other types of batteries may explode!
- ✓ All mains electrical supply safety features must be followed as described in 1.3. above.
- ✓ Disconnect the transformer plug from the charging base and the mains power supply when not in use.
- ✗ DO NOT expose the charging base to damp or wet conditions (for indoor use only).
- ✗ DO NOT pull or carry the charging base by the transformer power lead.
- ✗ DO NOT operate the charging base if it has been dropped, or has received a sharp knock, or is damaged. Contact an authorised service agent.
- ✗ DO NOT dismantle the charging base as this may cause damage or personal injury and will invalidate your warranty.
- ✗ DO NOT insert foreign objects or material into the hole reserved for the battery.
- ✗ DO NOT force the battery into the charging base. The battery will only fit one way to ensure correct polarity alignment.
- ✗ DO NOT immediately charge a second battery. Consecutive charging will overheat the charging base. Allow the unit to cool for 15 minutes before charging the next battery.
- ✗ DO NOT attempt to connect two charging bases together.
- ✓ Store the charging base in the same manner as battery, see para. 1.2.

## 2. SPECIFICATIONS

Chuck size	.....10mm
Motor	.....12V
No load speed	.....700 rpm
Max torque	......90 kg.cm
Full charge time	......3 - 5 hours
HSS Drill Bits	......2, 3, 4, 5, 6mm
Screwdriver Bits	......Slotted 5mm, 6mm Phillips #1, #2
	Double ended - Phillips #1 x Slotted 5mm - Phillips #2 x Slotted 7mm
Sockets	......5, 6, 7, 8, 9, 10mm + adaptor

#### Operating capacity on one charge.

Approximate, depending on material, drill sharpness, drill/screw diameter etc. and please note that full battery capacity will only be achieved after several charges.

Drilling - wood	.....126 holes x 25mm deep	Screw-driving -	200 screws x 30mm long
metal	..... 6 holes x 16mm deep		

## 3. OPERATING INSTRUCTIONS

**Note:** When new, the battery will have been shipped in a low charge state. It will take longer to charge the battery initially (about 8 hours) and several subsequent charges may also take a little longer than when the battery reaches its optimum performance.

### 3.1. Charging the battery pack.

- 3.1.1. To remove the battery pack from the drill, depress the two side clips (fig.1 item 7). Do not touch the metal battery terminals.
- 3.1.2. Place drill in carrying case and remove the battery charging base and transformer plug.
- 3.1.3. Connect mains transformer to the charging base (fig.2) and place the base on a safe flat surface. Plug the transformer into mains socket and switch on. The green power light will come on.
- 3.1.4. The battery is designed to fit into the charging base one way only. This is to ensure that the positive (+) and negative (-) polarities correspond. Align the + and - polarity marks on the base of the battery with the + and - marks on the charging base, insert the battery and press lightly to seat the battery firmly into the charging base, as in fig.2.

**WARNING!** DO NOT try to force battery into the base with crossed polarities.

- 3.1.5. The red charge light will come on when the battery is inserted into the charging base, and will remain on until the battery is removed from the base. Under normal conditions the battery will take 3 - 5 hours to fully charge from flat.

NOTE: It will take about 8 hours for the initial charge (see Section header note).

- 3.1.6. Remove the battery from the charging base and the red light will go out. Switch off and unplug the transformer from the mains. Push the battery into the drill base until it latches into place. The drill is now ready for use.
  - 3.1.7. Place the transformer plug and charging base back into the case.
- Note: Attempting to recharge a battery immediately after use may result in the red charge light not coming on. In such a case allow the battery to cool for a time and try again.

### 3.2. Drilling instructions. (Ensure you have read, understood and comply with all the safety instructions)

**WARNING!** always wear approved safety glasses when drilling.

#### 3.2.1. Preparation

- 1. Open the chuck by holding the rear collar (fig.3 'B') and turning the front chuck collar (fig.3 'A') See direction arrow on chuck.
- 2. Insert the required drill bit into the full length of the chuck and tighten.
- 3. Check the drill to ensure the direction switch (fig.1 item 3) is in the mid (lock) position.
- 4. Insert the battery pack into the base of the drill and latch into place.
- 5. The speed of the drill is controlled by the electronic variable speed switch (fig.1 item 4). After moving direction switch to 'forward' (or 'reverse') press the speed switch gently for a slow speed and progressively increase the pressure on the switch to produce correspondingly higher speeds (try before starting to drill).

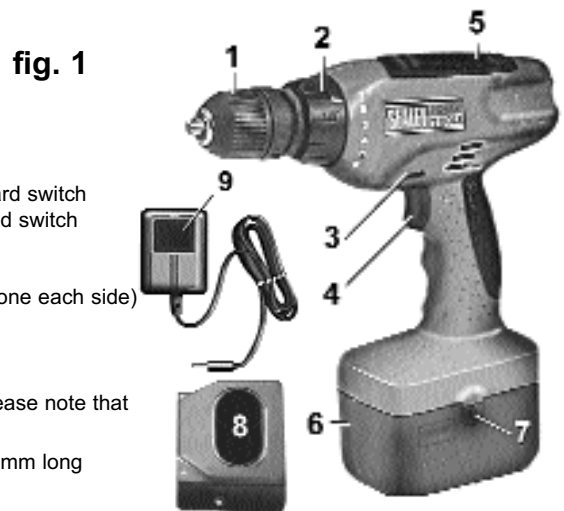

fig. 1

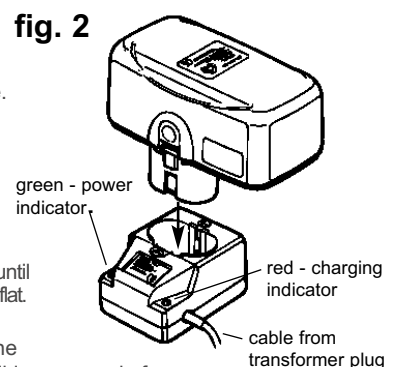

fig. 2

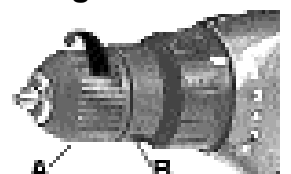

fig. 3

### 3.2.2. Torque setting

Torque is the amount of turning force applied when you use the drill.

Torque setting '1' (fig.4 'C') is the lowest and will apply the least effort - to the final turns of a screw, for example.

The torque becomes progressively greater with increased setting numbers, up to a maximum of '6'.

The combination of variable speed and torque gives maximum drilling efficiency.

Suggested torque settings:

- |                              |                          |
|------------------------------|--------------------------|
| 1. Small screws              | 4. Screws into hard wood |
| 2. Screws into soft material | 5. Regular drilling      |
| 3. Screws into hard material | 6. Heavy drilling        |

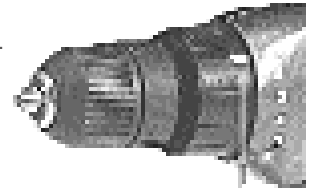

fig. 4 C

### 3.2.3. To drill holes

Lock a pilot drill (smaller size drill than the finished hole size) into the chuck.

Select an appropriate torque setting (para. 3.2.2.).

Check to confirm the turning direction is correct (change by direction switch, fig.1 item 3).

*DO NOT attempt to change direction whilst the drill is running.*

Drill a pilot hole in the middle of the spot where the final hole is to be drilled.

Insert the final sized drill bit. Hold drill firmly and place the drill bit at the entrance of the pilot hole and press the trigger as in 3.2.1.

If the drill becomes stuck, release the switch and place the chuck in reverse by pressing the direction switch to the other side (fig.1 item 3).

If this does not work, gently work the drill bit free. If the chuck stops turning, check the torque setting.

### 3.2.4. As a screw or bolt driver.

Lock appropriate tool bit in the chuck, set appropriate torque and proceed with the task. To remove screws, bolts, etc., switch the drill to reverse.

### 3.2.5. When you have finished working, remove the bit from the chuck, clean drill and bit and store in the carry case.

## 4. PARTS LIST

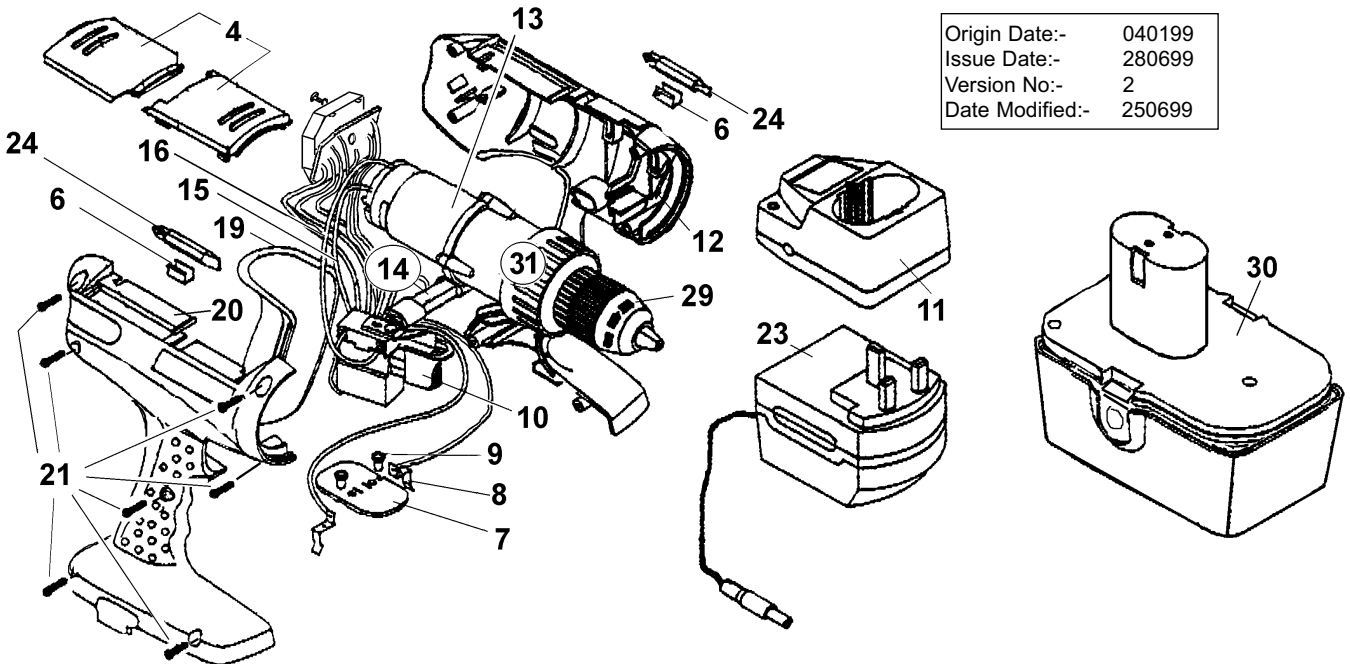

Origin Date:-	040199
Issue Date:-	280699
Version No:-	2
Date Modified:-	250699

ITEM	PART No	DESCRIPTION	ITEM	PART No	DESCRIPTION	ITEM	PART No	DESCRIPTION
4	NA1298/04	Cover, front top	12	NA1298/12	Cover housing	21	NA1298/21	Screw, self tapping
6	NA1298/06	Holder, metal bit	13	NA1298/13	motor, 12v	23	NA1298/23	Mains transformer
7	NA1298/07	Holder, connector plate	14	NA1298/14	Switch, reverse	24	NA1298/24	Bit,screwdriver
8	NA1298/08	Plate, contact	15	NA1298/15	Wire	29	NA1298/29	Chuck, 3/8" keyless
9	NA1298/09	Rivet	16	NA1298/16	Wire	30	CB12/BP	Battery pack
10	NA1298/10	Switch, variable speed	19	NA1298/19	Support, handle	31	NA1298/31	Gearbox assembly
11	NA1298/11	Charging base	20	NA1298/20	Support housing			

**Declaration of Conformity** We, the sole importer into the UK, declare that the products listed below are in conformity with the following EEC standards and directives.

**Cordless Drill, Charging Unit & Transformer Plug**  
Model CP12V

73.23/EEC LV Directive (S.I. 1994/3260)  
89/336/EEC EMC Directive



The construction files for these products are held by the Manufacturers and may be inspected on request by contacting Jack Sealey Ltd

Signed by Mark Sweetman

1st June 1999

For Jack Sealey Ltd.  
Sole importer into the UK  
of Sealey Power Products

**NOTE:** It is our policy to continually improve products and as such we reserve the right to alter data, specifications and component parts without prior notice.

**IMPORTANT:** No liability is accepted for incorrect use of product. **WARRANTY:** Guarantee is 12 months from purchase date, proof of which will be required for any claim. **INFORMATION:** For a copy of our latest catalogue, call us on 01284 757525 and leave your full name and address, including postcode.



**SEALEY POWER TOOLS**

Sole UK Distributor  
Sealey Group,  
Bury St. Edmunds, Suffolk.



01284 757500



01284 703534

**E-mail:** sales@sealey.co.uk