

MODEL Nos: **CHARGE106, CHARGE107, CHARGE110, CHARGE112, CHARGE115, CHARGE124**

Thank you for purchasing a Sealey product. Manufactured to a high standard this product will give you years of trouble free performance if these instructions are carefully followed and the product is correctly maintained.



**IMPORTANT: PLEASE READ THESE INSTRUCTIONS CAREFULLY. NOTE THE SAFE OPERATIONAL REQUIREMENTS, WARNINGS AND CAUTIONS. USE THIS PRODUCT CORRECTLY AND WITH CARE FOR THE PURPOSE FOR WHICH IT IS INTENDED. FAILURE TO DO SO MAY CAUSE DAMAGE AND/OR PERSONAL INJURY AND WILL INVALIDATE THE WARRANTY. PLEASE RETAIN THESE INSTRUCTIONS FOR FUTURE USE.**

### 1. SAFETY INSTRUCTIONS

#### 1.1. ELECTRICAL SAFETY

**WARNING!** It is the responsibility of the owner and the operator to read, understand and comply with the following:

You must check all electrical products, before use, to ensure that they are safe. You must inspect power cables, plugs, sockets and any other connectors for wear or damage. You must ensure that the risk of electric shock is minimised by the installation of appropriate safety devices. A Residual Current Circuit Breaker (RCCB) should be incorporated in the main distribution board. We also recommend that a Residual Current Device (RCD) is used. It is particularly important to use an RCD with portable products that are plugged into a supply which is not protected by an RCCB. If in any doubt consult a qualified electrician. You may obtain a Residual Current Device by contacting your Sealey dealer.

**You must also read and understand the following instructions concerning electrical safety.**

- 1.1.1. The **Electricity at Work Act 1989** requires that all portable electrical appliances, if used on business premises, are tested by a qualified electrician, using a Portable Appliance Tester (PAT), at least once a year.
- 1.1.2. The **Health & Safety at Work Act 1974** makes owners of electrical appliances responsible for the safe condition of those appliances and the safety of the appliance operators. **If in any doubt about electrical safety, contact a qualified electrician.**
- 1.1.3. Ensure that the insulation on all cables and on the appliance is safe before connecting it to the power supply. See 1.1.1. and 1.1.2. and use a Portable Appliance Tester.
- 1.1.4. Ensure that cables are always protected against short circuit and overload.
- 1.1.5. Regularly inspect power supply cables and plugs for wear or damage and check all connections to ensure that none is loose.
- 1.1.6. **Important:** Ensure that the voltage marked on the appliance matches the power supply to be used and that the plug is fitted with the correct fuse - see fuse rating at right.
- 1.1.7. **DO NOT** pull or carry the appliance by the power cable.
- 1.1.8. **DO NOT** pull the plug from the socket by the cable.
- 1.1.9. **DO NOT** use worn or damaged cables, plugs or connectors. Immediately have any faulty item repaired or replaced by a qualified electrician. When a BS 1363/A UK 3 pin plug is damaged, cut the cable just above the plug and **dispose of the plug safely.**

Fit a new plug according to the following instructions (UK only).

**a) Connect the BROWN live wire to the live terminal 'L'.**

**b) Connect the BLUE neutral wire to the neutral terminal 'N'.**

**c) After wiring, check that there are no bare wires, that all wires have been correctly**

**connected, that the cable outer insulation extends beyond the cable restraint and that the restraint is tight.**

Double insulated products, which are always marked with this symbol , are fitted with live (brown) and neutral (blue) wires only. To rewire, connect the wires as indicated above - **DO NOT** connect either wire to the earth terminal.

- 1.1.10. If an extension reel is used it should be fully unwound before connection. A reel with an RCD fitted is preferred since any appliance plugged into it will be protected. The cable core section is important and should be at least 1.5mm<sup>2</sup>, but to be absolutely sure that the capacity of the reel is suitable for this product and for others which may be used in the other output sockets, we recommend the use of 2.5mm<sup>2</sup> section cable.

#### 1.2. GENERAL SAFETY

- WARNING!** Disconnect the charger from the mains power before servicing or performing any maintenance.
- ✓ Disconnect the charger from the mains power before connecting to, or disconnecting from the battery.
- ✓ Maintain the charger in good condition (use an authorised service agent only).
- WARNING!** The charger has components such as switches and relays which may cause sparks or arcs. When using the charger in a garage or workshop, make sure that it is in a safe location.
- ✓ Keep the charger clean for best and safest performance.
- WARNING!** Ensure that there are no sources of ignition in or near the work area i.e. naked flames, cigarettes, heaters etc. as the charging process produces explosive gases.
- WARNING!** Ensure that the work area is well ventilated as the gases produced are explosive.
- ✓ Locate the charger in a suitable work area and keep the area clean and tidy and free from unrelated materials. Ensure that there is adequate lighting.
- ✓ Wear approved safety eye protection (standard spectacles are not adequate).
- ✓ Remove ill fitting clothing. Remove ties, watches, rings and other loose jewellery and contain long hair.
- ✓ Read vehicle manufacturer's manual to check for any specific battery charging information.
- ✓ Disconnect the battery from the vehicle and move it to a safe, dry, level area for charging. If the battery cannot be removed from the vehicle refer to manufacturer's manual.
- ✓ Check that the electrolyte level in the battery is above the plates. If not, add distilled water to cover them by 5 - 10mm. **DO NOT** touch the battery fluid as it is corrosive.
- ✓ Clean the charger clamps and battery terminals, before connecting the charger, to ensure good contact.
- ✓ Ensure that the correct polarity clamp is attached to the correct terminal of the battery. POSITIVE is indicated by + and red and NEGATIVE is indicated by - and black. If there are no identifiable symbols, the NEGATIVE terminal is the one which is connected directly to the vehicle body.
- ✓ Remove the battery electrolyte cover or caps to allow the gases produced by charging to escape.
- ✓ Keep children and unauthorised persons away from the work area.
- x **DO NOT** attempt to charge a non-rechargeable battery.
- x **DO NOT** use the charger for any purpose other than that for which it is designed.
- x **DO NOT** allow untrained persons to operate the charger.
- x **DO NOT** place the charger inside the vehicle. Remove the battery to a safe distance for charging.

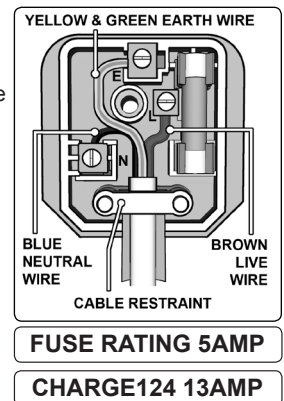

- x **DO NOT** allow the charger terminal clamps to touch each other when the power is on or the charger fuse will blow. Remember that gases are produced which may ignite if sparks occur.
- x **DO NOT** get the charger wet or use in damp or wet locations or areas where there is condensation.
- x **DO NOT** operate the charger if it is damaged.
- x **DO NOT** attempt to modify or open the charger.
- ✓ When not in use, unplug from the mains power supply and store in a safe, dry, childproof area.



**DANGER! BE AWARE, LEAD-ACID BATTERIES GENERATE EXPLOSIVE GASES DURING NORMAL BATTERY OPERATION. FOR THIS REASON, IT IS VERY IMPORTANT TO READ AND FOLLOW THESE INSTRUCTIONS CAREFULLY, EACH TIME YOU USE THE CHARGER.** Follow these instructions and those published by the battery and vehicle manufacturers and the manufacturer of any equipment you intend to use in the vicinity of the battery. Remember to review warning marks on all products and on engines.

### 1.3. PERSONAL PRECAUTIONS

- ✓ Ensure that there is another person within hearing of your voice and close enough to come to your aid, should a problem arise when working near a lead-acid battery.
- ✓ Wear safety eye protection and protective clothing. Avoid touching eyes while working near battery.
- ✓ Have fresh water and soap nearby in case battery acid contacts skin, clothing, or eyes.
- ✓ Wash immediately with soap and water if battery acid contacts skin or clothing. If acid enters eye, flush eye immediately with cool, clean running water for at least 15 minutes and seek immediate medical attention.
- ✓ Remove personal metallic items such as rings, bracelets, necklaces and watches. A lead-acid battery can produce a short-circuit current high enough to weld a ring to metal, which would cause severe burns.
- ✓ Ensure that hands, clothing (especially belts) are clear of fan blades and other moving or hot parts of the engine. Remove ties and contain long hair.
- x **DO NOT** smoke or allow a spark or flame in the vicinity of battery or engine.



This appliance is not intended for use by persons (including children) with reduced physical, sensory or mental capabilities or lack of experience and knowledge, unless they have been given supervision or instruction concerning the use of the appliance by a person responsible for their safety. Children should be supervised to ensure that they do not play with the appliance.

## 2. INTRODUCTION & SPECIFICATIONS

Supplied in steel case with carry handle, these single phase chargers feature plenty of ventilation to help maintain low transformer temperatures. A large ammeter displays rate of charge and a dash-mounted fuse provides polarity protection in the event that clips are connected incorrectly. Rocker switches control variable output to the battery to maintain peak condition. Suitable for regular and low maintenance batteries. Supplied with 2200mm length output cables with heavy-duty crocodile clips and are fitted with ASTA/BS approved non-rewirable 3-pin safety plug.

MODEL No.	CHARGE106	CHARGE107	CHARGE110	CHARGE112	CHARGE115	CHARGE124
Rated charging current:	6A	7A	10A	12A	15A	24A
Maximum charging current (Boost):	8A	11A	14A	16A	19A	28A
Charging capacity:	10-95Ah	20-105Ah	20-120Ah	20-200Ah	20-250Ah	25-320Ah
Volts Output:	12/24V	12/24V	12/24V	12/24V	12/24V	12/24V
Volts Input:	230V	230V	230V	230V	230V	230V
Watts Input:	100W	150W	200W	200W	700W	1000W
Charging Rates:	2	2	2	2	2	2
Polarity protection	Fuse (1 x 15A)	Fuse (1 x 15A)	Fuse (1 x 20A)	Fuse (1 x 30A)	Fuse (1 x 30A)	Fuse (1 x 40A)
Input Protection Fuse	T3A	T3A	T4A	T5A	T5A	T6A

## 3. CHARGING INSTRUCTIONS

### 3.1. Preparation

It is important to correctly prepare for charging, ensuring that you follow Section 1 safety instructions carefully. Check that the capacity of the battery is compatible with the charger output. Charging current (amps) should not exceed one tenth of the value of the battery capacity (amp hours).

- 3.1.1. Follow the vehicle manufacturer's instructions for charging the battery. Note special instructions for charging vehicle batteries in situ.
- 3.1.2. Check the battery to ensure that the POSITIVE and NEGATIVE terminals are clearly identifiable before removing the battery from the vehicle.
- 3.1.3. Subject to 3.1.1. above, disconnect and remove the battery from the vehicle and place in an appropriate safe area ready for charging.
- 3.1.4. If possible, remove the battery electrolyte cover or caps to allow the gases produced by charging to escape.
- 3.1.5. Check that the electrolyte is covering the plates inside. If not, add distilled water so that the plates are covered by 5-10mm.
- 3.1.6. The charge status of the battery may be determined by use of a hydrometer to measure the specific gravity (relative density) of the electrolyte: **1.28 = Fully charged 1.21 = Half charged 1.14 = Fully discharged.**



**WARNING! Be cautious and vigilant - the electrolyte is a highly corrosive acid.**

### 3.2. Connecting the charger to the battery.

Ensure that the battery charger is unplugged from the mains power supply before connecting the leads to the battery.

- 3.2.1. Select the charger voltage to match that of the battery by setting the rocker switch to either 12 or 24 volts.
- 3.2.2. Initially, always set the Charge Rate rocker switch to 'MIN'.
- 3.2.3. Check that the charger clamps and battery terminals are clean and free from oxidation.
- 3.2.4. Connect the chargers POSITIVE (red) lead to the POSITIVE (+) terminal on the battery, and the NEGATIVE (black) lead to the NEGATIVE (-) terminal on the battery.

### 3.3. Charging the battery

- 3.3.1. Connect the charger to the mains power supply and turn it on with the front panel mounted ON/OFF switch.
- 3.3.2. Check the current delivery to the battery by reading the ammeter on the front of the battery charger. During charging the pointer on the ammeter will slowly move to the left according to the capacity and condition of the battery (see fig.1, meter face may vary according to model).
- 3.3.3. If a boost charge is required, ensure that an initial charge has built up first before moving the Charge Rate rocker switch to 'BOOST'.
- 3.3.4. To indicate that the battery is fully charged the reading on the ammeter should be at the "0" output indicator. To correspond with this the electrolyte in the battery will begin to gas. Stop charging at this point in order to protect the battery plates from damage.

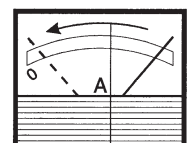

fig.1

- ❑ **WARNING! The charger will not switch off automatically. The state of charge should be regularly monitored by the person with responsibility for charging the battery. Do not leave the charger operating unattended or overnight.**
- 3.3.5. Unplug the charger from the mains power supply and **then** disconnect the clamps from the battery terminals. Clean and store the charger in a safe, dry area.
- 3.3.6. Replace the battery electrolyte cover or caps. Wipe up any splashes or spillages, remembering that the electrolyte is a corrosive acid. Return the battery to the vehicle, secure according to the manufacturer's instructions and re-connect the power leads. Check to ensure that all tools are removed before closing the bonnet or boot.
- 3.4. ❑ **WARNING! LOW MAINTENANCE or SEALED "NO MAINTENANCE" BATTERY CHARGING**
- 3.4.1. A low, or no maintenance battery, **must** be charged slowly. **DO NOT** use the 'Boost' setting. Continually monitor the voltage across the battery terminals and when it reaches 14.4 volts, stop charging.

**4. MULTIPLE BATTERY CHARGING**

- 4.1. A number of batteries may be charged at the same time. To do so we recommend "parallel connection" as shown in fig.2A
- 4.2. Two 12 volt batteries may be charged in series using the 24 volt output as shown in fig.2B. This is only recommended if both batteries are of similar capacity and are in a similar state of discharge.

**5. FUSE & THERMAL PROTECTION**

- 5.1. Your charger is equipped with two front panel mounted fuses. The output protection fuse on the left will interrupt the circuit in the following circumstances:
  - a) Overload: too high a current to the battery.
  - b) Short circuit: clamps touch, or the polarity on battery is reversed.
 If the output fuse blows take the following action:
  - 5.1.1. Disconnect the charger from the mains power supply.
  - 5.1.2. Allow the unit to cool down, establish the reason for fuse blowing and correct.
  - 5.1.3. Replace the fuse using only a Sealey replacement fuse.
- 5.2. The input protection fuse is situated to the right hand side of the control panel. If this fuse blows, replace only with a Sealey fuse of the same value.
- 5.3. **Thermal Protection.** When a high current causes the charger to overheat the internal thermal protection will cut off the current. When the charger has cooled sufficiently it will automatically reconnect.

fig.2

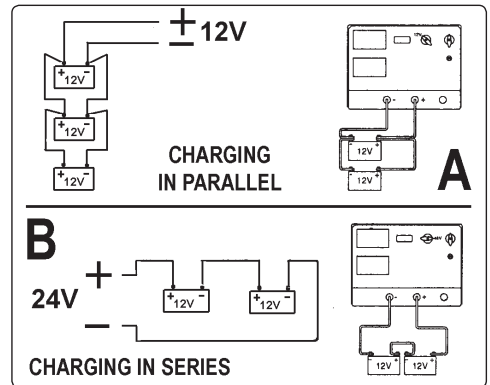

CHARGE106



CHARGE124



CHARGE115



CHARGE110

Parts support is available for these product. To obtain a parts listing and/or diagram, please log on to [www.sealey.co.uk](http://www.sealey.co.uk), email [sales@sealey.co.uk](mailto:sales@sealey.co.uk) or phone 01284 757500.

**NOTE:** It is our policy to continually improve products and as such we reserve the right to alter data, specifications and component parts without prior notice.  
**IMPORTANT:** No liability is accepted for incorrect use of this product.  
**WARRANTY:** Guarantee is 12 months from purchase date, proof of which will be required for any claim.  
**INFORMATION:** For a copy of our latest catalogue and promotions call us on 01284 757525 and leave your full name and address, including postcode.



Sole UK Distributor, Sealey Group,  
 Kempson Way, Suffolk Business Park,  
 Bury St. Edmunds, Suffolk,  
 IP32 7AR



01284 757500  
 01284 703534



[www.sealey.co.uk](http://www.sealey.co.uk)  
[sales@sealey.co.uk](mailto:sales@sealey.co.uk)