

Thank you for purchasing a Sealey product. Manufactured to a high standard this product will, if used according to these instructions and properly maintained, give you years of trouble free performance.

⚠ IMPORTANT: PLEASE READ THESE INSTRUCTIONS CAREFULLY. NOTE THE SAFE OPERATIONAL REQUIREMENTS, WARNINGS & CAUTIONS. USE THE PRODUCT CORRECTLY AND WITH CARE FOR THE PURPOSE FOR WHICH IT IS INTENDED. FAILURE TO DO SO MAY CAUSE DAMAGE AND/OR PERSONAL INJURY AND WILL INVALIDATE THE WARRANTY. PLEASE KEEP INSTRUCTIONS SAFE FOR FUTURE USE.

1. SAFETY INSTRUCTIONS



DANGER! BE AWARE, LEAD-ACID BATTERIES GENERATE EXPLOSIVE GASES DURING NORMAL BATTERY OPERATION. FOR THIS REASON, IT IS VERY IMPORTANT TO READ AND FOLLOW THESE INSTRUCTIONS CAREFULLY, EACH TIME YOU USE THE BATTERY TESTER.
 Follow these instructions and those published by the battery and vehicle manufacturers, and the maker of any equipment you intend to use in the vicinity of the battery. Remember to review warning marks on all products and on engines.

1.1. PERSONAL PRECAUTIONS

- ✓ Ensure that there is another person within hearing range and close enough to come to your aid, should a problem arise when working near a lead-acid battery.
- ✓ Wear safety eye protection and protective clothing. Avoid touching eyes while working near battery.
- ✓ Have fresh water and soap nearby in case battery acid contacts skin, clothing, or eyes.
- ✓ Wash immediately with soap and water if battery acid contacts skin or clothing. If acid enters eye, flush eye immediately with cool, clean running water for at least 15 minutes and seek immediate medical attention.
- ✓ Remove personal metallic items such as rings, bracelets, necklaces and watches. A lead-acid battery can produce a short-circuit current which is high enough to weld such items to the vehicle and cause severe burns.
- ✓ Ensure that hands, clothing (especially belts) are clear of fan blades and other moving or hot parts of engine. Remove ties and contain long hair.
- x **DO NOT** smoke or allow a spark or flame in the vicinity of the battery or engine.



1.2. GENERAL SAFETY INSTRUCTIONS

- ✓ Familiarise yourself with the application, limitations and potential hazards of the tester. Also refer to the vehicle manufacturer's hand book. *IF IN ANY DOUBT CONSULT A QUALIFIED ELECTRICIAN.*
- ✓ Ensure that the tester is in good condition before use. If in any doubt do not use the unit and contact a qualified electrician.
- ✓ Only use recommended attachments and parts. To use unapproved items may be dangerous and will invalidate your warranty.
- ✓ Keep tools and other items away from the engine and ensure that you can see the battery and working parts of engine clearly.
- ✓ Determine the system voltage before using the tester.
- ✓ If the tester receives a sharp knock or blow the unit must be checked by a qualified service agent before using.
- ✓ If the battery terminals are corroded or dirty, clean them before using the tester.
- ✓ Keep children and unauthorised persons away from the work area.
- x **DO NOT** disassemble the tester for any reason. The tester must only be checked by qualified service personnel.
- **WARNING!** To prevent the risk of sparking, short circuit and possible explosion **DO NOT** drop metal tools in the battery area, or allow them to touch the battery terminals.
- x **DO NOT** cross-connect tester to battery. Ensure positive (RED) clamp is to positive terminal and negative (BLACK) clamp is to negative terminal. If battery symbols cannot be distinguished, remember that the negative terminal is the one directly connected to the vehicle bodywork.
- x **DO NOT** use the tester outdoors, or in damp, or wet locations and **DO NOT** use in the vicinity of flammable liquids or gases.
- ✓ Ensure there is effective ventilation to prevent a build-up of explosive gases.
- x **DO NOT** use the tester for a task for which it is not designed.
- ✓ When not in use, store the tester carefully in a safe, dry, childproof location.

2. INTRODUCTION & SPECIFICATION

Professional diagnosis of battery and alternator faults with the added facility to print the results. Test battery condition with as little as 1Volt of residual charge. No heat, no sparks and no misdiagnosis. Checks condition of alternator - no complicated connections or interpretation required. Analyse the charging system at rest and under load to determine condition of the alternator. Connect and follow the prompts on the 2-line/16 character LCD screen for straightforward answers. Incorporates simple voltmeter for voltage tests and additional system diagnostics. Rugged construction. Supplied in sturdy carry-case with batteries, two rolls of printing paper and instruction manual.

Rated Battery Voltage: 6-12V
 Charging System Capability:..... 12, 24V
 Rated Systems:..... DIN, EN, IEC, JIS, SAE
 Test Range: 25-1300CCA DIN
 40-2100CCA EN
 30-1500CCA IEC
 By battery type JIS
 40-2000CCA SAE

Min. Power Requirement:..... 1V
 Printer rolls (Pack of 2): BT2003.01
 Note: CCA = Cold Cranking Amps



3. OPERATION & USE

- **WARNING!** Ensure that you read, understand and apply the safety and operational instructions before connecting the tester clamps to the battery. Only when you are sure that you understand the procedures is it safe to proceed with the testing process.
- 3.1 PREPARATION**
- **WARNING!** Ensure that the vehicle, or battery, is in a well ventilated area before starting to test.
- 3.1.1 Check battery casing for cracks or leakage. If damage is found DO NOT test, replace battery.
- 3.1.2 Clean battery terminals.
- 3.1.3 If possible, check electrolyte levels and top-up with distilled water as necessary.
- 3.1.4 Unless otherwise specified tests are carried out with all electrical items switched off. **Leaving any items on (boot light, interior light, etc.) can result in misdiagnosis.**
- 3.1.5 Confirm that the 4x AA Batteries (supplied) are correctly fitted in the compartment in the rear of the tester.
Note that nothing will be seen on the display until the tester is connected to a vehicle battery.
- 3.1.6 Connect the red clamp to the positive (+) battery terminal and the black clamp to the negative (-) terminal. When the internal battery becomes discharged the display will read **INTERNAL BATTERY LOW.**
- 3.1.7 If there is a poor connection the display will read **CHECK CLAMPS**, otherwise the display will read either **BATTERY TEST** or **SYSTEM TEST** or **LANGUAGE.**
- 3.1.8 Paper Load: Open the clear cover. Insert the paper in the feeder, it will auto feed in to the printer.

3.2 DISPLAY GENERAL

By pressing the < (forward) and > (backward) buttons the display will cycle through the options. Press ENTER button when the option you require is displayed.

3.2.1 **System Analyser** will display initially and then automatically switch to **Battery Test**.

3.2.2 Use the < (forward) and > (backward) buttons to cycle between **System Test**, **Language Select**, and **Battery Test**. (Fig. 1)

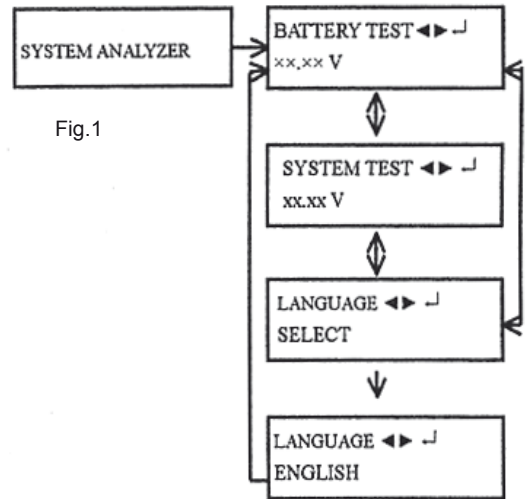

Fig.1

Battery Type:

- Regular liquid.
- AGM Flat Plate.
- AGM Spiral.
- Gel.

3.3 BATTERY TEST

3.3.1 With battery test screen displayed press ENTER.

3.3.2 Use the < (forward) and > (backward) buttons to select the battery type: Regular Liquid, AGM Flat Plate, AGM Spiral, Gel. Press ENTER to confirm choice.



3.3.3 Use the < (forward) and > (backward) buttons to select the battery rating: SAE, EN, IEC, DIN or JIS. Press ENTER to confirm.

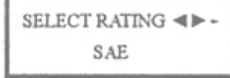

3.3.4 Use the < (forward) and > (backward) buttons to input the battery capacity. CCA: DIN: 25 - 1300 EN: 40-2100 IEC: 30 - 1500 JIS: By battery type SAE: 40 - 2000 Press ENTER to begin test.



3.3.5 Test Battery for 1 second.



3.3.6 Press < (forward) or > (backward) buttons to select battery fully charged: Yes or No. Press ENTER to confirm choice.

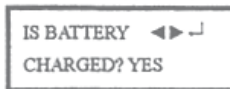

3.3.7 When the test is complete, the LCD shows the actual volts and CCA. One of the following results will be displayed.

3.3.8 **GOOD & PASS:** Battery is capable of holding a charge.



3.3.9 **GOOD & RECHARGE:** The battery is good but needs to be recharged.



3.3.10 **RECHARGE & RETEST:** Battery is discharged, the battery condition cannot be determined until it is fully charged. Recharge and retest.



3.3.11 **BAD & REPLACE:** The battery will not hold its charge. Replace.



3.3.12 **LOAD ERROR:** The tested battery is larger than 2000CCA or 200Ah. Or the clamps are not connected properly. Please fully charge the battery and retest after excluding both previous reasons. If reading is the same, the battery should be replaced immediately.

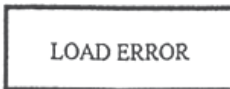

NOTE! The operator is asked if any accessories are left on as a possible cause. If accessories are left on, the operator is instructed to charge and retest the battery. If accessories are not left on, the operator is instructed to replace the battery since the charging system is working and a good battery should have accepted a charge.

3.3.13 Press < (forward) or > (backward) buttons to select result printing: Yes or No. Press

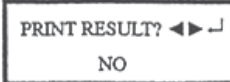

ENTER to confirm choice.

3.3.14 Remove the clamps from the battery after completion of testing.

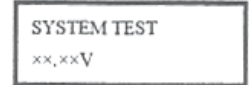

3.4 SYSTEM TEST

3.4.1 Press "ENTER" button, you will view the following screen.

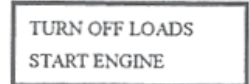

3.4.2 Turn off all vehicle accessory loads such as light, air conditioning, radio, etc. before starting the engine.

3.4.3 When the engine is started, one of the three results will be displayed along with the actual reading measured.

3.4.4 **CRANKING VOLTS NORMAL:** The system is showing normal draw. Press ENTER to perform the charging system test.

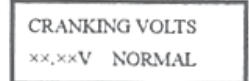

3.4.5 **cranking volts low:** The cranking voltage is below normal limits, troubleshoot the starter with manufacturer's recommended procedure

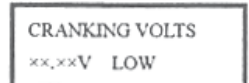

3.4.6 **CRANKING VOLTS NO DETECTED:** The cranking voltage is not detected.

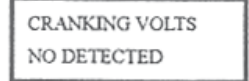

3.4.7 If the cranking voltage is normal, press ENTER to begin charging system test.

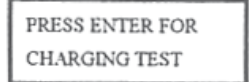

3.4.8 Press the ENTER key, you will view the following screen.

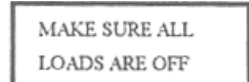

3.4.9 Press the ENTER key, one of the three following results will be displayed along with the actual reading measured.

LOW CHARGING VOLTS WHEN TESTED AT IDLE: The alternator is not providing sufficient current to the battery. Check the belt to ensure the alternator is rotating with engine running. If the belt is slipping or broken, replace and retest. Check the connections from the alternator to the battery. If the connection is loose or heavily corroded, clean or replace the cable and retest. If the belt and connections are in good condition, replace the alternator.

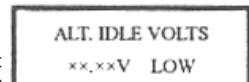

CHARGING SYSTEM NORMAL WHEN TESTED AT IDLE: The system is showing normal output from the alternator. No problem is detected.

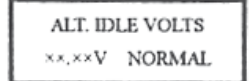

HIGH CHARGING VOLTS WHEN TESTED AT IDLE: The voltage output from the alternator to the battery exceeds the normal limits of a functioning regulator. Check to ensure there are no loose connections and the ground connection is good. If there are no connection problems, replace the regulator. Since most alternators have the regulator built-in, this will require you to replace the alternator. The normal limit of a typical automotive regulator is 14.6 volts. Check manufacturer's specifications for the correct limit, as it will vary by vehicle type and manufacturer.

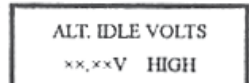

- 3.4.10 Following the charging system at idle, press ENTER for the charging system with accessory loads. Turn on the blower to high (heat), high beam headlights, and rear defogger. Do not use cyclical loads such as air conditioning or windshield wipers.
- 3.4.11 When testing older model diesel engines, run the engine to 2500 rpm for 15 seconds.
- 3.4.12 Press ENTER to look for the amount of ripple from the charging system to the battery. One of two testing results will be displayed along with the actual testing measured.
- 3.4.13 **RIPPLE DETECTED NORMAL:** Diodes function well in the alternator/stator.
- 3.4.14 **EXCESS RIPPLE DETECTED:** One or more diodes in the alternator are not functioning or there is stator damage. Check to ensure the alternator mounting is sturdy and that the belt is in good shape and functioning properly. If the mounting and belt are good, replace the alternator.
- 3.4.15 Press the "ENTER" key to continue the charging system test with accessory loads. One of the following three results will be displayed along with the actual test measured.

TURN ON LOADS
AND PRESS ENTER

RIPPLE DETECTED
xx,xxV NORMAL

OR
NO RIPPLE DETECT

RIPPLE DETECTED
xx,xxV HIGH

CHARGING SYSTEM HIGH WHEN TESTED WITH ACCESSORY LOADS: The voltage output from the alternator to the battery exceeds the normal limits of a functioning regulator. Check to ensure there are no loose connections and that the ground connection is normal. If there are no connection issues, replace the regulator. Since most alternators have the regulator built-in, this will require you to replace the alternator.

ALT. LOAD VOLTS
xx,xxV HIGH

CHARGING SYSTEM LOW WHEN TESTED WITH ACCESSORY LOADS: The alternator is not providing sufficient current for the system's electrical loads and the charging current for the battery. Check the belt to ensure the alternator is rotating with the engine running. If the belt is slipping or broken, replace and retest. Check the connections from the alternator to the battery. If the connection is loose or heavily corroded, clean or replace the cable and retest. If the belts and connections are in good working condition, replace the alternator.

ALT. LOAD VOLTS
xx,xxV LOW

CHARGING SYSTEM NORMAL WHEN TESTED WITH ACCESSORY LOADS: The system is showing normal output from the alternator. No problem detected.

ALT. LOAD VOLTS
xx,xxV NORMAL

- 3.4.16 Press ENTER when charging system test is completed. Turn all accessory loads and engine off. Press ENTER to return to step 1 or remove the test clamps from the battery posts after completion of testing to end test.

TEST OVER. TURN
OFF LOADS & ENGINE

□ **Please note 24V SYSTEM TEST result can be printed when connecting on 12V battery. Please refer to the following instruction.**

24V System Test Printing: The printer will not function for 24 Volt batteries system test printing. The 24V system test result will be recorded until you connect to a 12V battery and the correct screen displays. Please select "YES" and press enter key to print the result and then disconnect the clamps. The screen will appear again after you reconnect the clamps. Please select "NO" and press the enter key to go back to the main menu.

PRINT 24V SYSTEM
RESULT? YES

NOTE: It is our policy to continually improve products and as such we reserve the right to alter data, specifications and component parts without prior notice.
IMPORTANT: No liability is accepted for incorrect use of this product.
WARRANTY: Guarantee is 12 months from purchase date, proof of which will be required for any claim.
INFORMATION: For a copy of our latest catalogue and promotions call us on 01284 757525 and leave your full name and address, including postcode.



Sole UK Distributor, Sealey Group,
 Kempson Way, Suffolk Business Park,
 Bury St. Edmunds, Suffolk,
 IP32 7AR

01284 757500

01284 703534

www.sealey.co.uk

sales@sealey.co.uk