

Thank you for purchasing a Sealey product. Manufactured to a high standard this product will, if used according to these instructions and properly maintained, give you years of trouble free performance.



IMPORTANT: PLEASE READ THESE INSTRUCTIONS CAREFULLY. NOTE THE SAFE OPERATIONAL REQUIREMENTS, WARNINGS AND CAUTIONS. USE THIS PRODUCT CORRECTLY AND WITH CARE FOR THE PURPOSE FOR WHICH IT IS INTENDED. FAILURE TO DO SO MAY CAUSE DAMAGE OR PERSONAL INJURY, AND WILL INVALIDATE THE WARRANTY. PLEASE KEEP INSTRUCTIONS SAFE FOR FUTURE USE.

1. SAFETY INSTRUCTIONS

- X DO NOT use the cycle carrier if any parts are missing or damaged as this may cause failure or possible personal injury.
- WARNING!** Due to the variety in design of vehicles & cycles, it is the users full responsibility to ensure no damage occurs whilst using this cycle carrier. Correct attachment of carrier to a vehicle is therefore critical and is beyond control of the manufacturer, distributor, or supplier.
- WARNING!** The user must secure the carrier and any cycles to be carried properly, checking the security frequently when in use.
- ✓ Use strong, good quality tie restraints for securing cycles to the carrier. DO NOT use string, or elasticated straps.
- WARNING!** The locking mechanism is spring loaded, operate with care.
- ✓ If the load obscures the vehicle registration plate or lights fit an auxiliary number plate and/or lighting system.
- ✓ Avoid damage caused by hot exhaust fumes do not position cycles directly next to the vehicles exhaust, especially the bicycle tyres. If necessary fit an exhaust deflector.
- ✓ Ensure that bicycles do not come into contact with the vehicle bodywork and provide protection as required.
- WARNING!** Remove any loose objects from the bikes i.e pumps, bottles etc.
- WARNING!** Avoid any protrusions beyond the side of the car as these may present a risk of injury to passers-by.
- X DO NOT use the cycle carrier for any purpose other than for which it is designed.
- X DO NOT strap any other items to the carrier, only bicycles.
- WARNING!** Drive carefully - Be aware of cross winds, sudden braking or hard cornering, reduce speed accordingly when using carrier.
- WARNING!** This carrier is designed for temporary use only, remove when not in use or before going through a car wash.
- ✓ Every time before use check the carrier for security of fittings or any sign of wear and tear. Replace any worn or damaged parts.
- WARNING!** Remember the driver of the vehicle is responsible for the security and safety of the load carried.

2. FITTING INSTRUCTIONS

This cycle carrier has been designed and manufactured for safe use with a wide range of various vehicle makes and models. It is however the users full responsibility to ensure the safe fixing and use of the carrier. Ensure you have read and understood the safety instructions above.

- 2.1 Unfold cycle support arms (3).
- 2.2 Security pin (5) is secured to the frame by a small chain.
- 2.3 Position the cycle carrier (2) on to the 50mmØ tow ball (1) as illustrated.
- 2.4 Press down on the central locking bars until the latch (4) clicks into the locked position.
- 2.5 Insert the security pin (5) into hole (A) and through the locking bars to prevent latch (4) from releasing.
- 2.6 Check that the carrier is securely locked onto the tow ball (1). For added security a padlock may be passed through the holes provided in the locking bars.
- 2.7 To remove the carrier, remove the security pin (5), press down on latch (4), the locking bars will now fold upwards releasing the carrier from the tow ball.
- 2.8 When placing cycles on the rack, avoid positioning the tyres close to the exhaust. When carrying two cycles, place them in opposite directions on the carrier. Ensure that the cycles are well balanced.
- 2.9 Secure cycles on the carrier using suitable ties (DO NOT use string or elasticated ties). Ensure that cycles are not in contact with the vehicle bodywork and provide suitable protection to prevent damage.
- 2.10 Many modern vehicles are fitted with towing eyes which are suitable for attaching anti-theft cables to secure the cycles carried.
- 2.11 When carrying cycles drive with extra care, particularly in high winds or over uneven surfaces. If the load obscures the vehicle registration plate or lights, it is necessary to provide an auxiliary number plate and lighting system.

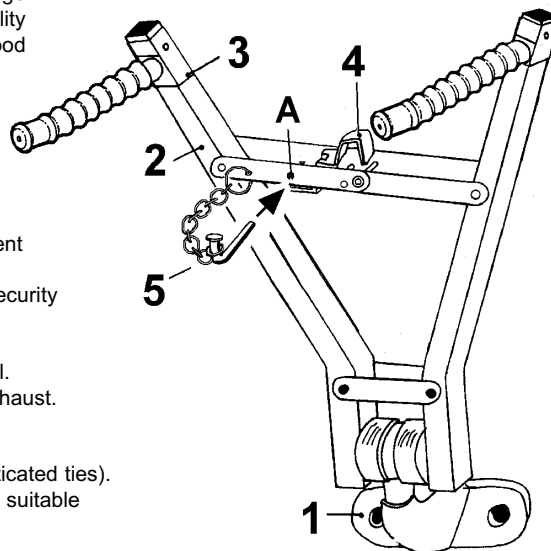

NOTE: It is our policy to continually improve products and as such we reserve the right to alter data, specifications and component parts without prior notice.

IMPORTANT: No liability is accepted for incorrect use of this equipment

WARRANTY: Guarantee is 12 months from purchase date, proof of which will be required for any claim.

INFORMATION: Call us for a copy of our latest catalogue on 01284 757525 and leave your full name and address including your postcode.

