

Thank you for purchasing a Sealey product. Manufactured to a high standard this product will, if used according to these instructions and properly maintained, give you years of trouble free performance.



**IMPORTANT: PLEASE READ THESE INSTRUCTIONS CAREFULLY. NOTE THE SAFE OPERATIONAL REQUIREMENTS, WARNINGS & CAUTIONS. USE THE PRODUCT CORRECTLY AND WITH CARE FOR THE PURPOSE FOR WHICH IT IS INTENDED. FAILURE TO DO SO MAY CAUSE DAMAGE AND/OR PERSONAL INJURY, AND WILL INVALIDATE THE WARRANTY. PLEASE KEEP INSTRUCTIONS SAFE FOR FUTURE USE.**

## 1. SAFETY INSTRUCTIONS

### 1.1 GENERAL SAFETY

- ❑ **WARNING!** Ensure Health & Safety, local authority, and general workshop practice regulations are adhered to when using this Rollcab
- ✓ Locate Rollcab combination in a suitable working area.
- ✓ Keep the work area clean, uncluttered and ensure there is adequate lighting.
- ✓ Keep the Rollcab combination clean and tidy in accordance with good workshop practice.
- ✓ Keep children and unauthorised persons away from the working area.
- ✗ **DO NOT** use the Rollcab combination for any purpose other than that for which it is designed.
- ✗ **DO NOT** move the Rollcab combination with drawers open.
- ✗ **DO NOT** open more than one drawer at the same time.
- ✗ **DO NOT** step on the drawers.
- ✗ **DO NOT** use in damp work areas.
- ❑ **WARNING!** The warnings, cautions and instructions referred to in this instruction manual cannot cover all possible conditions and situations that may occur. It must be understood that common sense and caution are factors which cannot be built into this product, but must be applied by the operator.

## 2. INTRODUCTION & SPECIFICATIONS

All steel construction and manufactured with steel inner walls for extra strength and durability. Heavy-duty 45mm Ball Bearing drawer slides provide superior performance and carry heavier loads. Split smooth-rolling drawers to give added flexibility. Full height rear locking mechanism, locks drawers in multiple locations. Each drawer supplied with non-slip liner which helps protect against scratches and damage. Each lock supplied with two keys. Rust and solvent resistant powder coat paint finish. Features big Ø125 x 50mm rubber wheels. Each unit having two swivel castors with large toe locks and two fixed wheels.

Model No:	AP41139
13 Drawer Rollcab	
Overall Size:	1060 x 460 x 1090mm
Full Width Drawer:	930 x 410 x 90mm
Small Drawer (x4):	550 x 410 x 45mm
Medium Drawer (x4):	550 x 410 x 90mm
Small 1/2 Drawer:	310 x 410 x 45mm
Medium 1/2 Drawer:	310 x 410 x 90mm
Large 1/2 Drawer:	310 x 410 x 140mm
X-Large 1/2 Drawer:	310 x 410 x 300mm

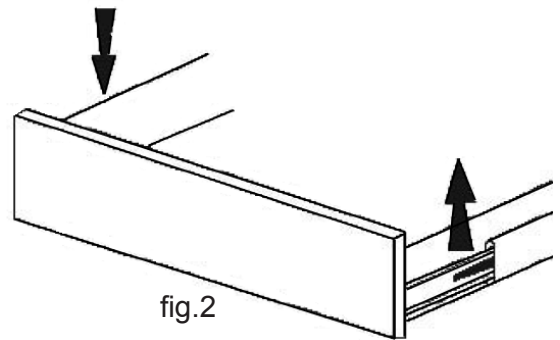
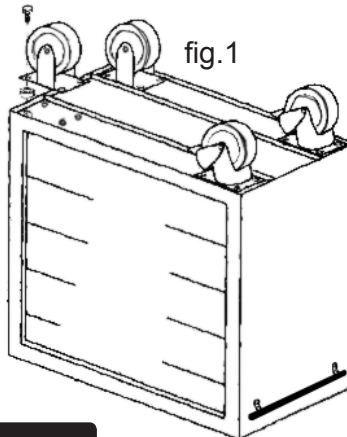

## 3. ASSEMBLY

- 3.1 Attach handle to Rollcab, ensure the securing brackets are facing down.
- 3.2 Flip Rollcab upside down onto its top. Attach the 2 swivel castors using 4 bolts and spacers (if supplied) per wheel, ensure they are at the handle end of the Rollcab, see fig.1.
- 3.3 Repeat with the fixed castors at the other end of the Rollcab (fig.1).
- 3.4 Ensure all fixings are secure and turn the Rollcab over onto its wheels.

## 4. OPERATION

- 4.1 To secure the Rollcab ensure the drawers are fully shut. Then lock the Rollcab with key.
- 4.2 To remove a drawer pull it all the way out, press down left tab and lift up right tab, then remove from sliders (fig.2)  
 To reinsert drawers realign with the sliders and push fully home.

## 5. MAINTENANCE

- 5.1 Periodically lubricate the drawer slides.
- 5.2 Clean the surfaces with a soft cloth and a mild water/detergent solution.
- 5.3 Check all fixings and tighten if required.

Parts support is available for this product. To obtain a parts listing and/or diagram, please log on to [www.sealey.co.uk](http://www.sealey.co.uk), email [sales@sealey.co.uk](mailto:sales@sealey.co.uk) or phone 01284 757500.

**NOTE:** It is our policy to continually improve products and as such we reserve the right to alter data, specifications and component parts without prior notice.  
**IMPORTANT:** No liability is accepted for incorrect use of this product.

**WARRANTY:** Guarantee is 12 months from purchase date, proof of which will be required for any claim.

**INFORMATION:** For a copy of our catalogue and latest promotions call us on 01284 757525 and leave your full name, address and postcode.