

SEALEY

13 DRAWER TOPCHEST & ROLL CAB COMBINATION WITH BALL-BEARING SLIDES - RED/GREY

MODEL NO: **AP22513BB.V3**

Thank you for purchasing a Sealey product. Manufactured to a high standard, this product will, if used according to these instructions, and properly maintained, give you years of trouble free performance.

IMPORTANT: PLEASE READ THESE INSTRUCTIONS CAREFULLY. NOTE THE SAFE OPERATIONAL REQUIREMENTS, WARNINGS & CAUTIONS. USE THE PRODUCT CORRECTLY AND WITH CARE FOR THE PURPOSE FOR WHICH IT IS INTENDED. FAILURE TO DO SO MAY CAUSE DAMAGE AND/OR PERSONAL INJURY AND WILL INVALIDATE THE WARRANTY. KEEP THESE INSTRUCTIONS SAFE FOR FUTURE USE.

1. SAFETY

- WARNING!** Ensure Health & Safety, local authority, and general workshop practice regulations are adhered to when using this Topchest & Rollcab combination.
- ✓ Locate the Topchest & Rollcab combination in a suitable working area.
- ✓ Keep the work area clean, uncluttered and ensure there is adequate lighting.
- ✓ Keep the Topchest & Rollcab combination clean and tidy in accordance with good workshop practice.
- ✓ Keep children and unauthorised persons away from the working area.
- ✗ **DO NOT** use the Topchest & Rollcab combination for any purpose other than that for which it is designed.
- ✗ **DO NOT** move the Topchest & Rollcab combination with drawers open.
- ✗ **DO NOT** open more than one drawer at the same time.
- ✗ **DO NOT** step on the drawers.
- ✗ **DO NOT** use in damp work areas.
- WARNING!** The warnings, cautions and instructions referred to in this instruction manual cannot cover all possible conditions and situations that may occur. It must be understood that common sense and caution are factors which cannot be built into this product, but must be applied by the operator.

2. INTRODUCTION

The economical way to buy American PRO® Ball-Bearing quality tool chests. Supplied packed one inside the other. This combo has smooth 25mm ball-bearing slides and all the features of the professional chests except that the swivel castors are Ø100mm. Features locks on both the topchest and rollcab, with removable steel bar on the rollcab and integral bars on the topchest. Supplied with two keys for each lock.

3. SPECIFICATION

Model No:..... AP22513.V3

W x D x H:

9 Drawer Topchest :

Overall Size:.....600 x 260 x 380mm

Small Split Drawer (x6):150 x 220 x 35mm

Small Drawer (x2):510 x 220 x 35mm

Medium Drawer (x1):.....510 x 220 x 80mm

4 Drawer Rollcab:

Overall Size:.....615 x 330 x 935mm

Small Drawer (x2):515 x 305 x 45mm

Medium Drawer (x2):.....515 x 305 x 80mm

Cupboard (x1):610 x 295 x 425mm

4. ASSEMBLY

4.1. Remove nuts, bolts and washers from base then lift off body, fig.1.

4.2. Remove base, fig.2 and reattach fig.3.

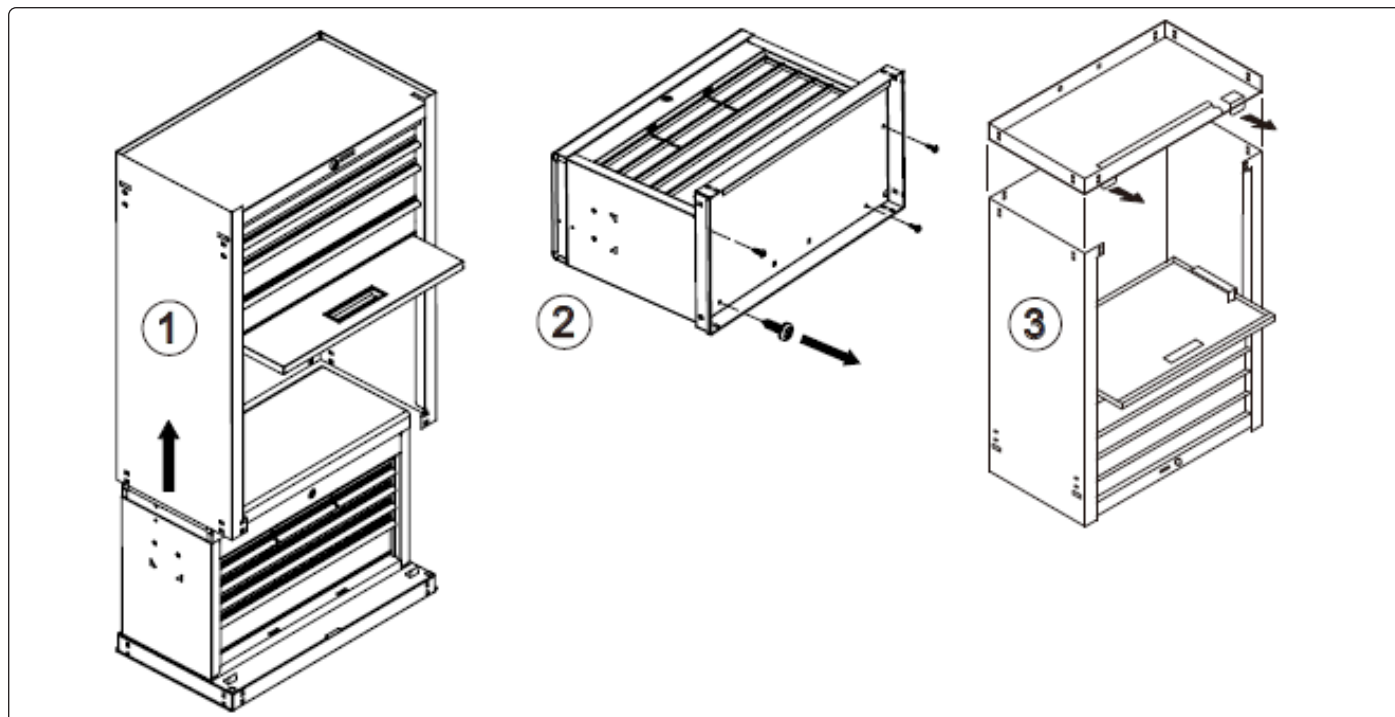

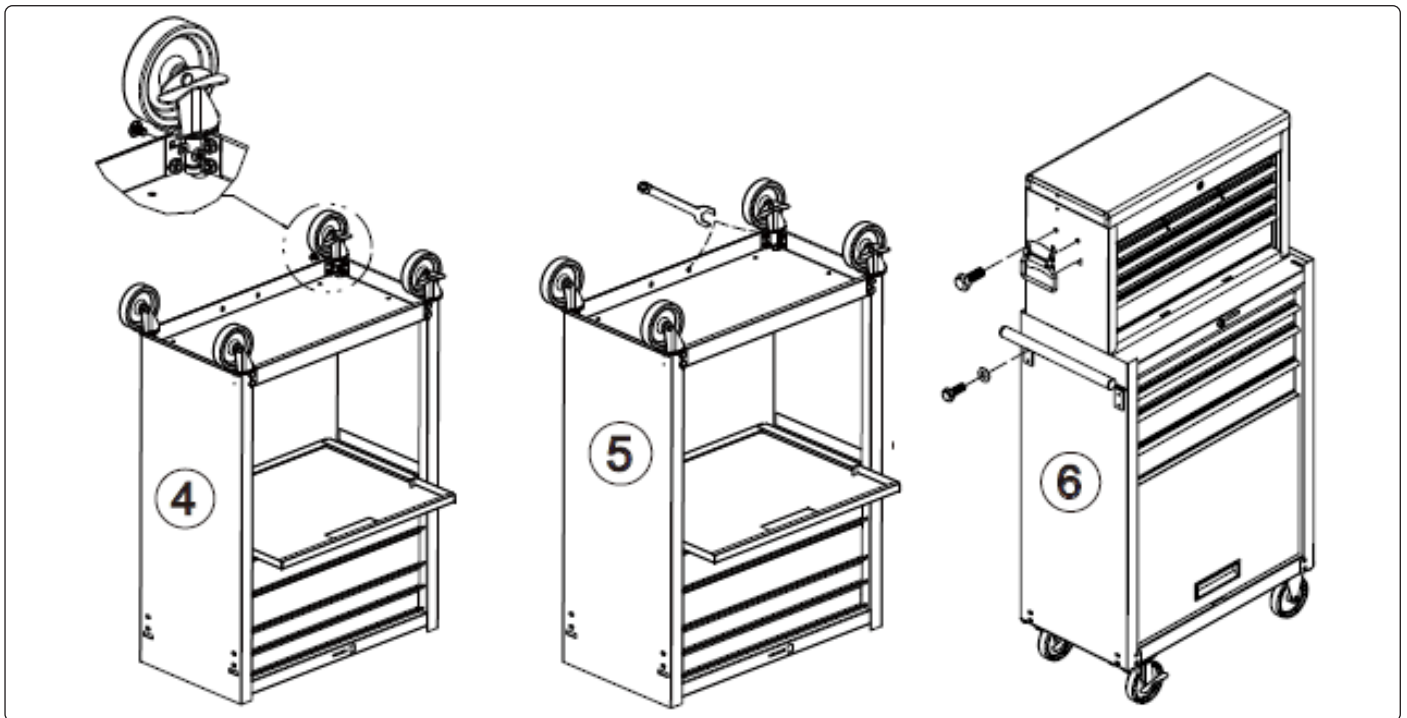

- 4.3. Fit castors, figs 4 and 5.
- 4.4. Fit chest side handles with bolts, fig.6.
- 4.5. Attach side handle onto cabinet and secure with four bolts and washers, see fig.6.

5. MAINTENANCE

- 5.1. Periodically lubricate castors and tighten all hardware.
- 5.2. Clean the surfaces with a soft cloth and a mild water/detergent solution.



ENVIRONMENT PROTECTION

Recycle unwanted materials instead of disposing of them as waste. All tools, accessories and packaging should be sorted, taken to a recycling centre and disposed of in a manner which is compatible with the environment. When the product becomes completely unserviceable and requires disposal, drain any fluids (if applicable) into approved containers and dispose of the product and fluids according to local regulations.

Note: It is our policy to continually improve products and as such we reserve the right to alter data, specifications and component parts without prior notice. Please note that other versions of this product are available. If you require documentation for alternative versions, please email or call our technical team on technical@sealey.co.uk or 01284 757505.

Important: No Liability is accepted for incorrect use of this product.

Warranty: Guarantee is 12 months from purchase date, proof of which is required for any claim.

Sealey Group, Kempson Way, Suffolk Business Park, Bury St Edmunds, Suffolk. IP32 7AR



01284 757500



01284 703534



sales@sealey.co.uk



www.sealey.co.uk