

SEALEY

6 DRAWER TOPCHEST & ROLLCAB COMBINATION WITH BALL-BEARING SLIDES - RED/GREY

MODEL NO: AP2200BB.V2

Thank you for purchasing a Sealey product. Manufactured to a high standard, this product will, if used according to these instructions, and properly maintained, give you years of trouble free performance.

IMPORTANT: PLEASE READ THESE INSTRUCTIONS CAREFULLY. NOTE THE SAFE OPERATIONAL REQUIREMENTS, WARNINGS & CAUTIONS. USE THE PRODUCT CORRECTLY AND WITH CARE FOR THE PURPOSE FOR WHICH IT IS INTENDED. FAILURE TO DO SO MAY CAUSE DAMAGE AND/OR PERSONAL INJURY AND WILL INVALIDATE THE WARRANTY.



Refer to instruction manual

1. SAFETY

1.1. GENERAL SAFETY

- WARNING!** Ensure Health & Safety, local authority, and general workshop practice regulations are adhered to when using this Topchest & Rollcab combination.
- ✓ Locate the Topchest & Rollcab combination in a suitable working area.
- ✓ Keep the work area clean, uncluttered and ensure there is adequate lighting.
- ✓ Keep the Topchest & Rollcab combination clean and tidy in accordance with good workshop practice.
- ✓ Keep children and unauthorised persons away from the working area.
- * **DO NOT use the Topchest & Rollcab combination for any purpose other than that for which it is designed.**
- * **DO NOT** move the Topchest & Rollcab combination with drawers open.
- * **DO NOT** open more than one drawer at the same time.
- * **DO NOT** step on the drawers.
- * **DO NOT** use in damp work areas.
- WARNING!** The warnings, cautions and instructions referred to in this instruction manual cannot cover all possible conditions and situations that may occur. It must be understood that common sense and caution are factors which cannot be built into this product, but must be applied by the operator.

2. ASSEMBLY

- 2.1. Remove the bolts, nuts and washers from the base of the rollcab (fig.1), and then lift off the body to uncover the topchest.
- 2.2. Remove the screws from the base (fig.2), and separate from the topchest, discard the screws.
NOTE: Place protective material onto the ground to avoid damaging the back of the topchest.
- 2.3. Turn the rollcab upside down and place the base into position as shown in fig.3A.
NOTE: Place protective material onto the ground to avoid damaging the top of the rollcab.
- 2.4. Position the corner brackets (fig.3B) and secure using bolts, washers and nuts.
- 2.5. Attach the back panel to the base using two bolts, washers and nuts.
- 2.6. Ensure the base is square in the rollcab and tighten all nuts fully (fig.3C).
- 2.7. Place the rollcab upright and place the topchest on top as shown in fig.4.

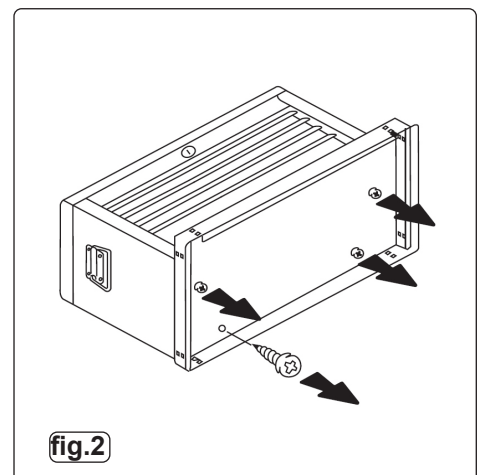
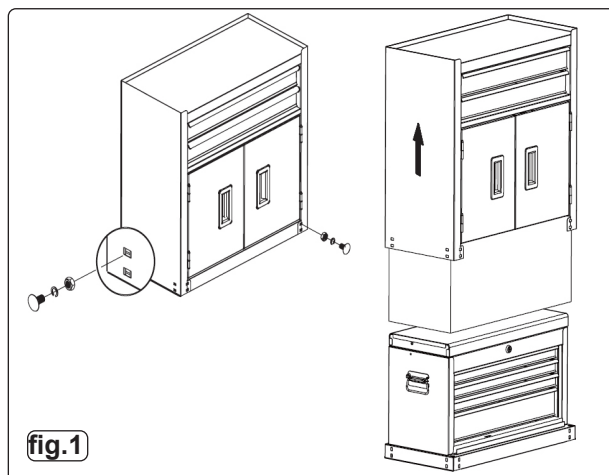
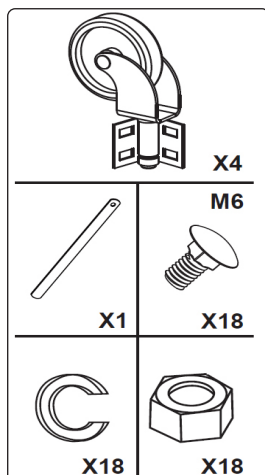

Specification (W x D x H):	
4 DRAWER TOPCHEST:	
Overall Size:	600 x 260 x 340mm
Small Drawer (x3):	510 x 225 x 35mm
Medium Drawer (x1):	510 x 225 x 85mm
2 DRAWER ROLLCAB:	
Overall Size:	615 x 295 x 705mm
Medium Drawer (x2):	515 x 275 x 65mm
Cupboard (x1)	610 x 275 x 375mm

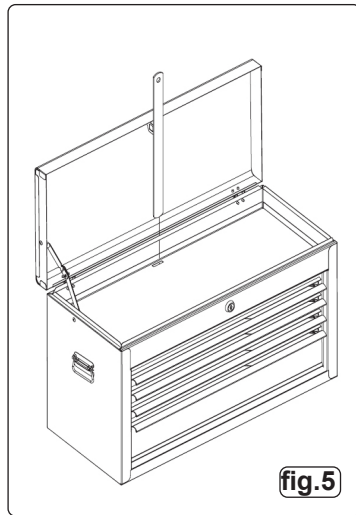
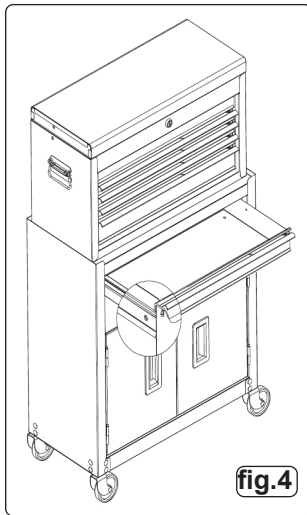
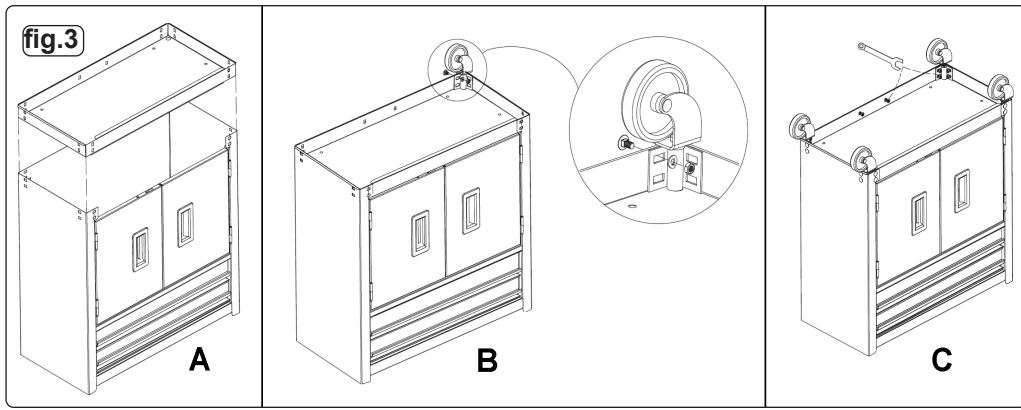

3. OPERATION

- 3.1. To lock the top chest, close all drawers, then insert one lock bar into the back slot inside the top compartment. Close the lid and lock with the key.

4. MAINTENANCE

- 4.1. Periodically lubricate the drawer slides (fig.5).
 4.2. Clean the surfaces with a soft cloth and a mild water/detergent solution.
 4.3. Check all fixings and tighten if required



ENVIRONMENT PROTECTION

Recycle unwanted materials instead of disposing of them as waste. All tools, accessories and packaging should be sorted, taken to a recycling centre and disposed of in a manner which is compatible with the environment. When the product becomes completely unserviceable and requires disposal, drain any fluids (if applicable) into approved containers and dispose of the product and fluids according to local regulations.

Note: It is our policy to continually improve products and as such we reserve the right to alter data, specifications and component parts without prior notice. Please note that other versions of this product are available. If you require documentation for alternative versions, please email or call our technical team on technical@sealey.co.uk or 01284 757505.

Important: No Liability is accepted for incorrect use of this product.

Warranty: Guarantee is 12 months from purchase date, proof of which is required for any claim.

Sealey Group, Kempson Way, Suffolk Business Park, Bury St Edmunds, Suffolk. IP32 7AR



01284 757500



01284 703534



sales@sealey.co.uk



www.sealey.co.uk