

Thank you for purchasing a Sealey product. Manufactured to a high standard this product will, if used according to these instructions and properly maintained, give you years of trouble free performance.



IMPORTANT: PLEASE READ THESE INSTRUCTIONS CAREFULLY. NOTE THE SAFE OPERATIONAL REQUIREMENTS, WARNINGS & CAUTIONS. USE THE PRODUCT CORRECTLY AND WITH CARE FOR THE PURPOSE FOR WHICH IT IS INTENDED. FAILURE TO DO SO MAY CAUSE DAMAGE AND/OR PERSONAL INJURY AND WILL INVALIDATE THE WARRANTY. PLEASE KEEP INSTRUCTIONS SAFE FOR FUTURE USE.

1. SAFETY INSTRUCTIONS

1.1 GENERAL SAFETY

- WARNING!** *Ensure Health & Safety, local authority, and general workshop practice regulations are adhered to when using this workstation.*
- WARNING!** Use workstation on level and solid ground, preferably concrete. *Avoid tarmacadam since the workstation may sink into the surface.*
- ✓ Locate workstation in a suitable working area.
- ✓ Keep the work area clean, uncluttered and ensure there is adequate lighting.
- ✓ Keep the workstation clean and tidy in accordance with good workshop practice.
- ✓ Keep children and unauthorised persons away from the working area.
- ✓ Make sure that the cabinet is securely fitted to the wall before use.
- x **DO NOT** use the workstation for any purpose other than that for which it is designed.
- x **DO NOT** undertake work on the workstation without the workpiece being adequately secured. Use clamps or a vice (not included) to secure the workpiece. Available from your Sealey dealer.
- x **DO NOT** use the workstation out of doors.
- x **DO NOT** get the workstation wet or use in damp or wet locations or areas where there is condensation.
- x **DO NOT** clean the workstation with any solvents which may damage the paint surface or the protective coating on the wooden top.

Note! The assembly of this product will require assistance.

2. INTRODUCTION AND SPECIFICATIONS

- 2.1 Workstation consisting of wooden worktop bench and wall mounting cabinet. Features one drawer, one deep cupboard, two slim cupboards, metal pegboard and open storage space with a removable shelf. All cupboards are lockable. Supplied with 20 hanging hooks. Ideal for keeping all tools close to hand while at work.

- 2.2 Size - Workbench (H x D x W): 860 x 600 x 1200mm
- Cabinet (H x D x W): 610 x 200 x 1200mm

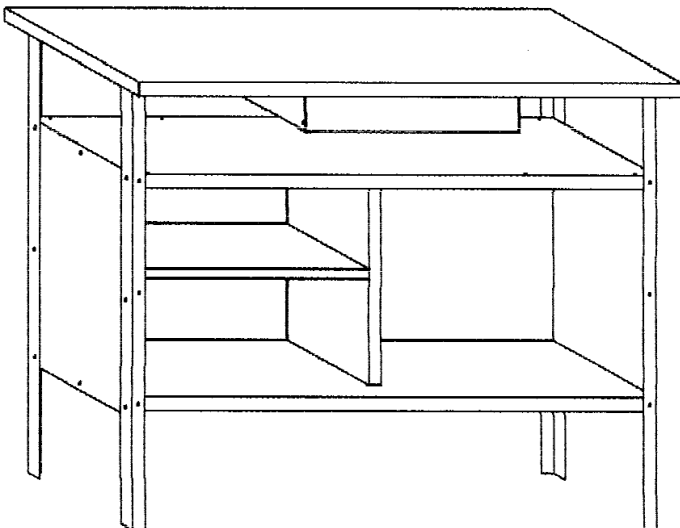
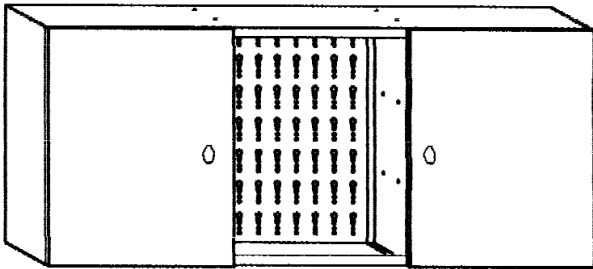

3. ASSEMBLY

Note! Follow instructions and diagrams to assemble the workstation properly. Pay close attention to the numbered panels and follow accordingly as some panels have specific uses e.g. some panels have shelf support slots.

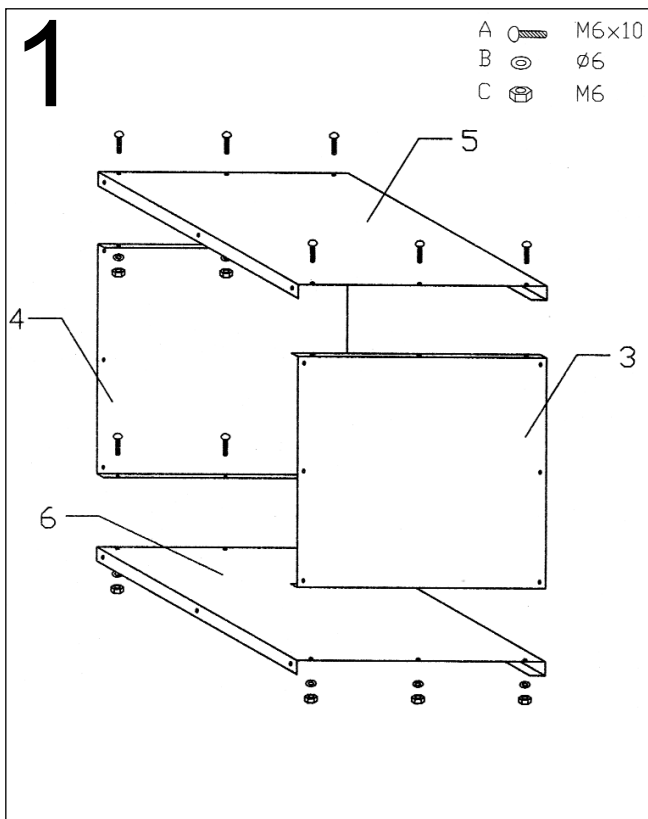

STEP 1. To assemble the lower storage area take two large (5. 6) and two small panels (3, 4) each with six holes and put them together as shown in the diagram above using 12 screws, 12 nuts and 12 washers. Make sure that the double bend lips on the larger panels are facing to the front. Also on panel 3 make sure that the shelf support slot is facing upwards.

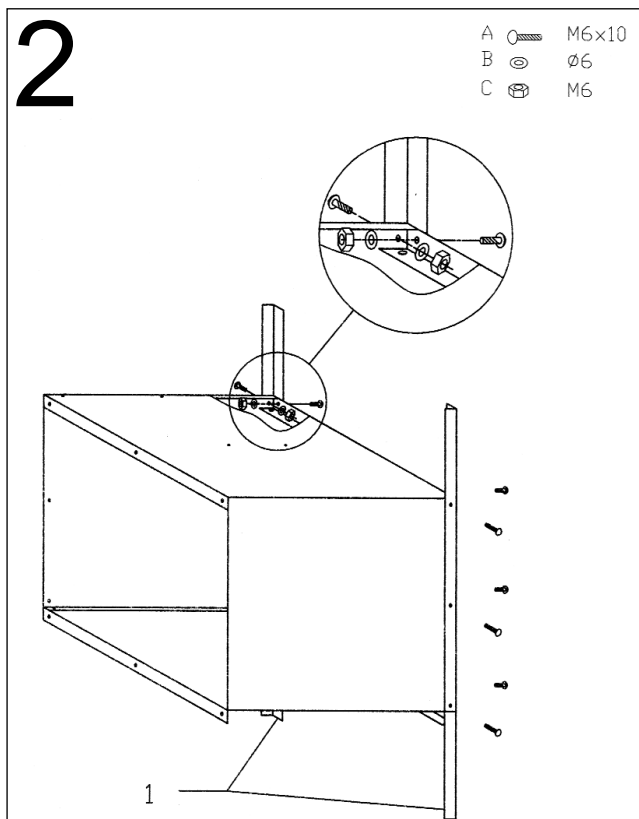

STEP 2. Next attach the two front legs (1) to the lower storage area. As shown in the diagram above the legs are retained with screws, washers and nuts.

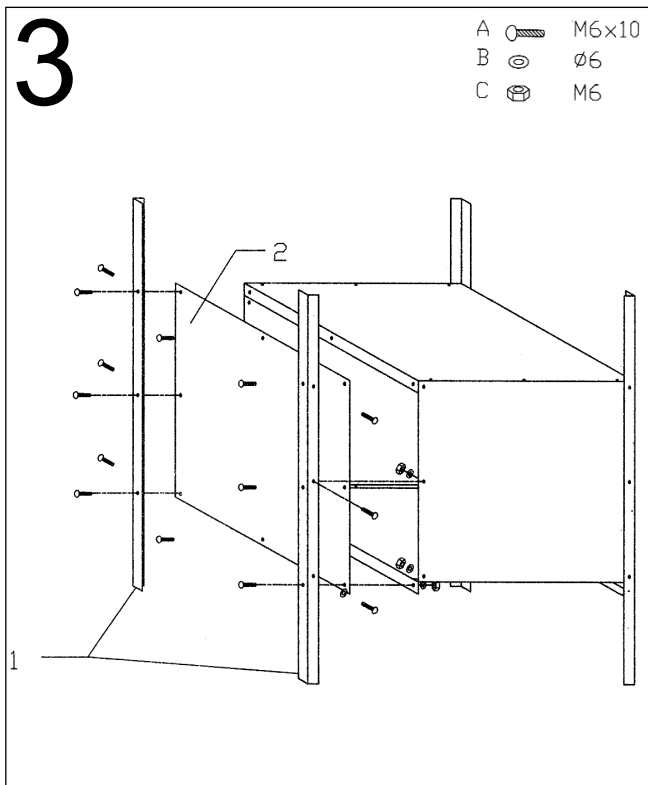

STEP 3. Attach rear legs (1) and back panel (2) at the same time, with the same screws. It may be easier to lay the unit down on its front for this step of the assembly.

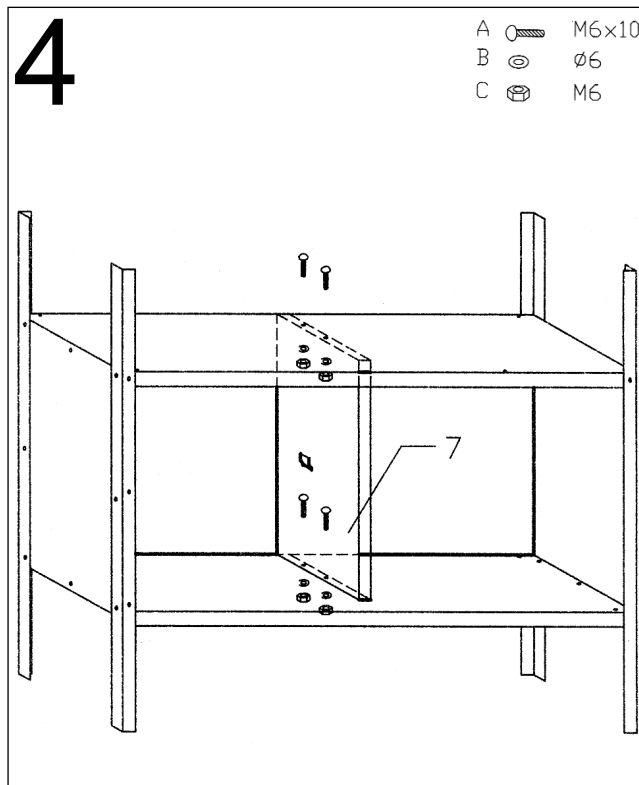

STEP 4. Next insert the internal partition (7). When in front of the workstation make sure that the liped side is facing right and the flat side with the shelf support slot is facing left.

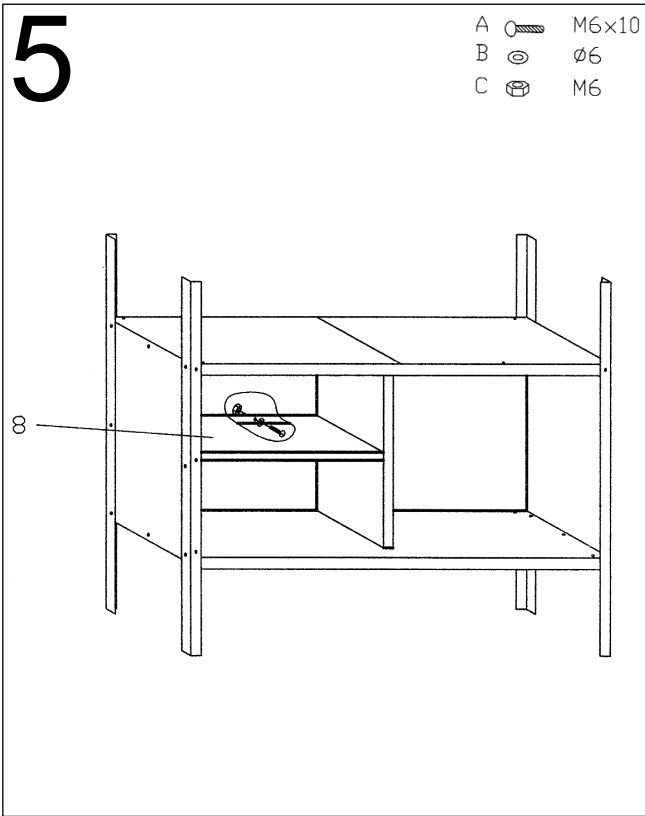

STEP 5. Follow the diagram above to fit the internal shelf (8). Use 1 screw, washer and nut to attach it to the back panel and then locate it in the side panel support slots.

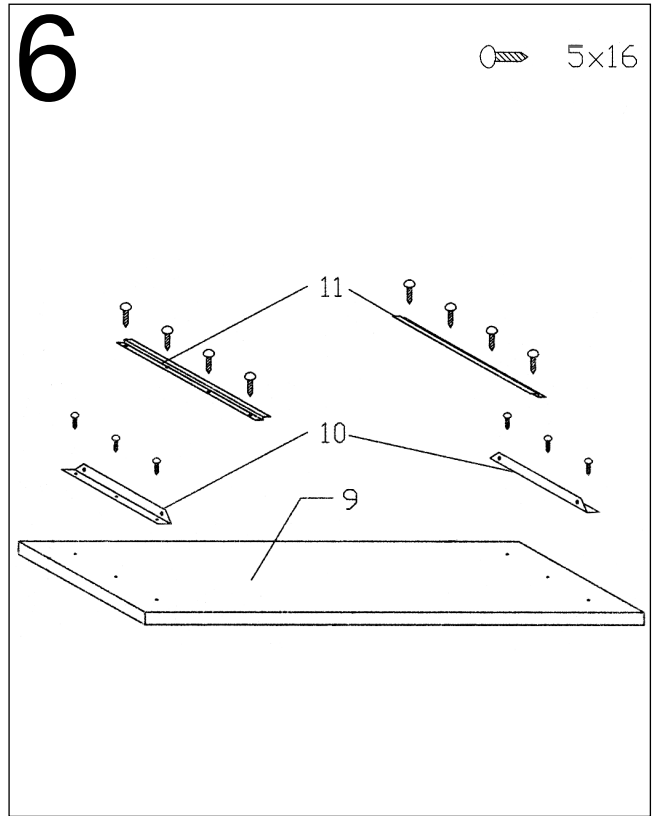

STEP 6. Place the wooden work surface (9) upside down so that the predrilled holes are visible, place the brackets (10) and drawer slots (11) on the underside of the work surface and secure with screws.

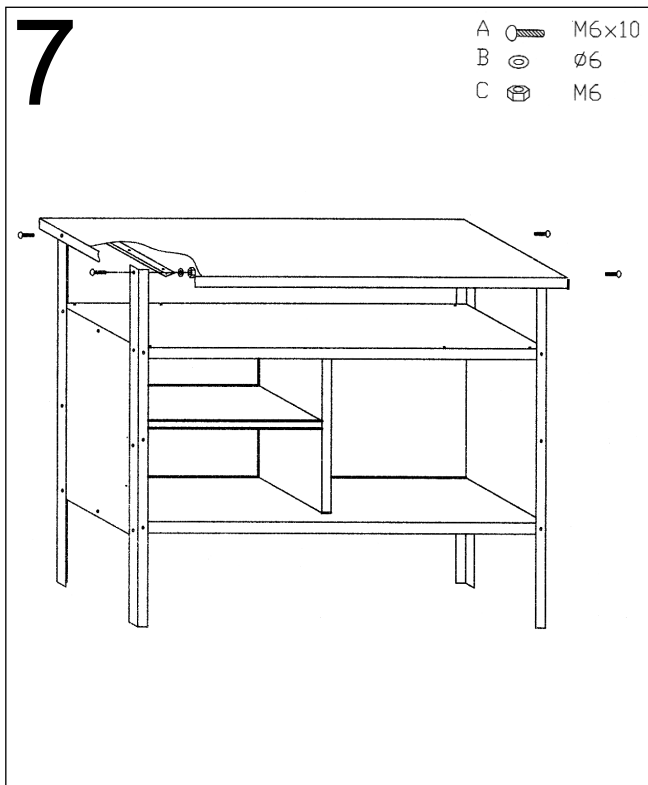

STEP 7. Turn the workstation upright and screw the legs onto the work surface brackets (10 attached in step 6).

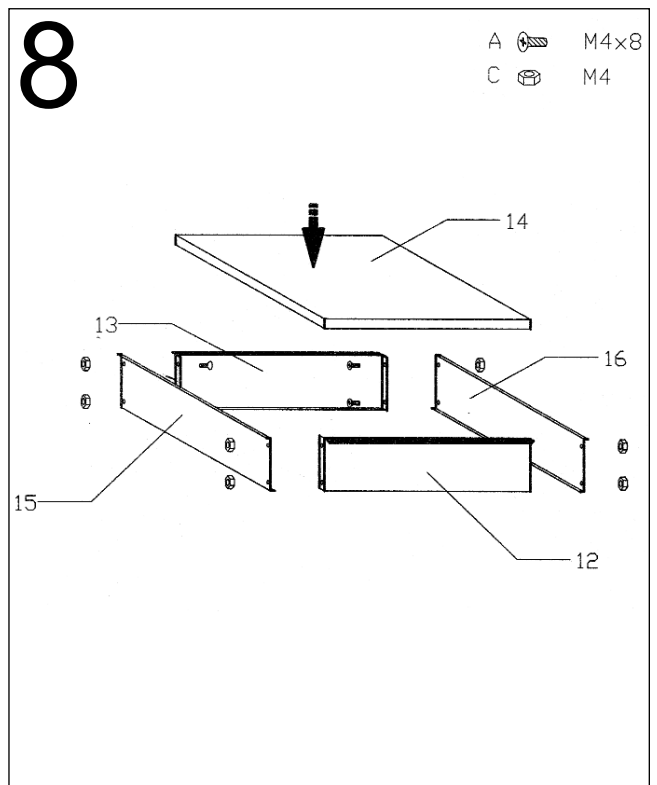

STEP 8. To make the drawer take parts 12, 13, 15, 16 and screw them together as show in the diagram above, making sure that the bottom lip of each panel is facing inwards. Then place the wooden base inside of the shelf.



STEP 9. When the work surface is secure slide the drawer into the slots that were fixed to the underside of the work surface at step 6.

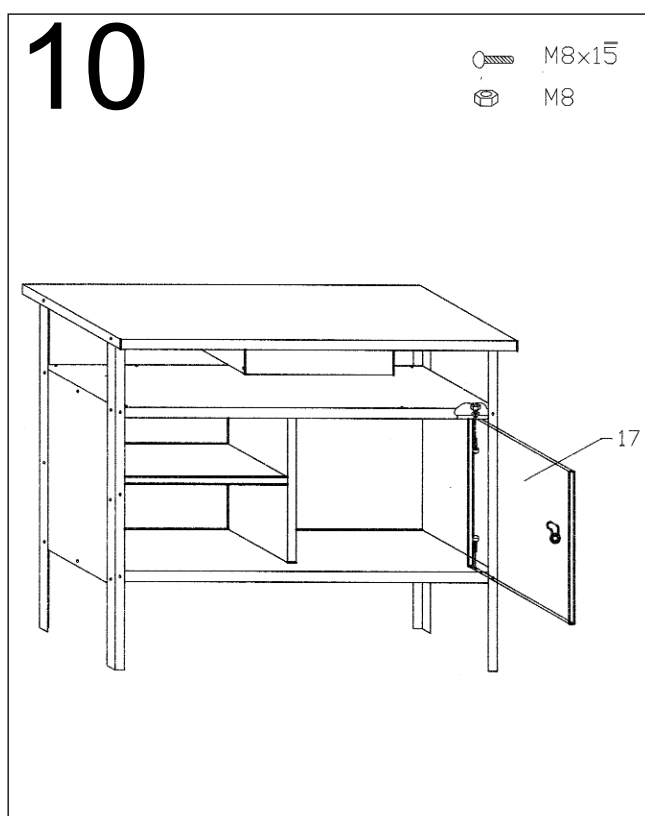

STEP 10. The righthand side of the lower storage area is going to be made into a cupboard, to do this take the cupboard door (17) and fix to the top and bottom panels of the lower storage area, as shown in the diagram above.

The workstation is complete.

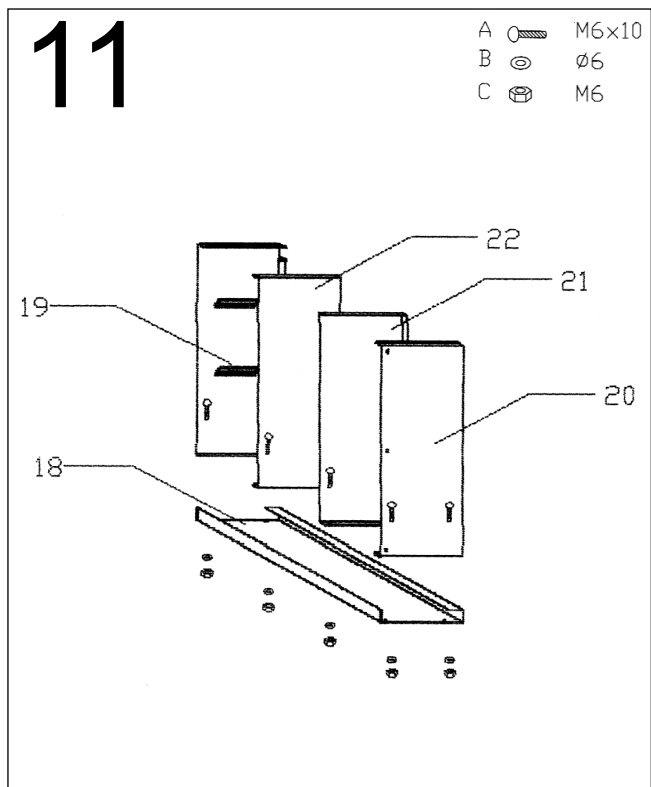

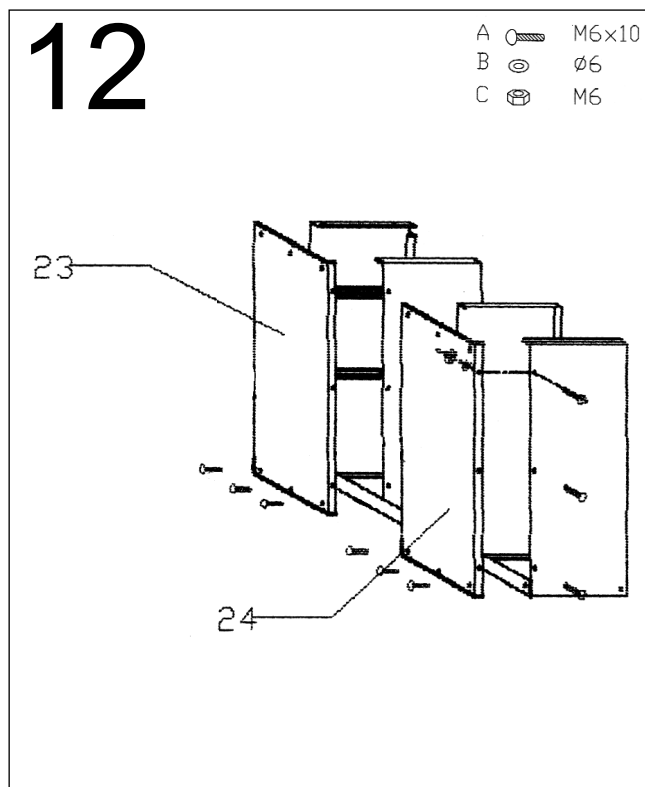

STEP 11. To make the cabinet take panels 18, 19, 20, 21, 22 and screw them together as in the diagram, making sure that on 18 the double bend lip is facing the front and that 19 and 22 have the lipped edge facing each other and the same with 20 and 21.



STEP 12. Attach the back panels (23, 24). These fit inside the bottom ledge of the base. Screw from the side and the bottom, as shown above.

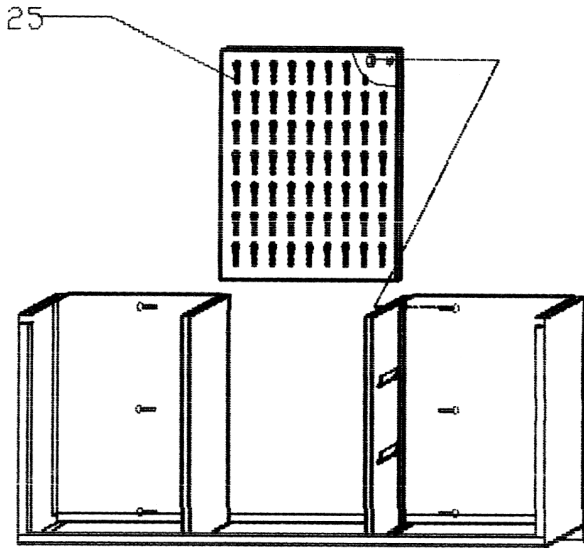

13

- A  M6x10
- B  Ø6
- C  M6



STEP 13. Next insert the hanging panel (25) make sure that it is the correct way up and that the sides with the lipped edges are facing backwards.

14

- A  M6x10
- B  Ø6
- C  M6

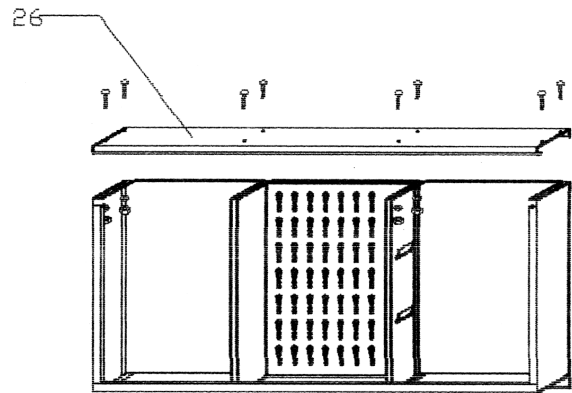

STEP 14. Screw on the top panel (26) of the cabinet making sure that the double bend lip is facing the front.

15

- AA  M6x12
- B  Ø6
- C  M6

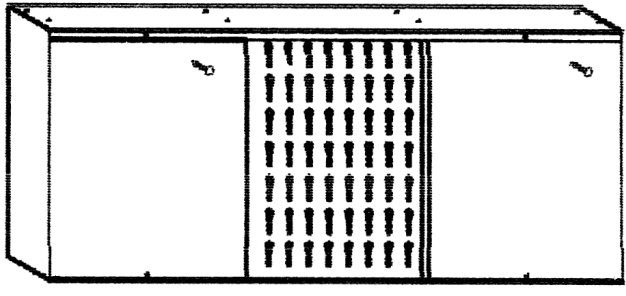

STEP 15. After completing step 14, screw the top of the back panels securely.

16

- AA  M6x12
- B  Ø6
- C  M6

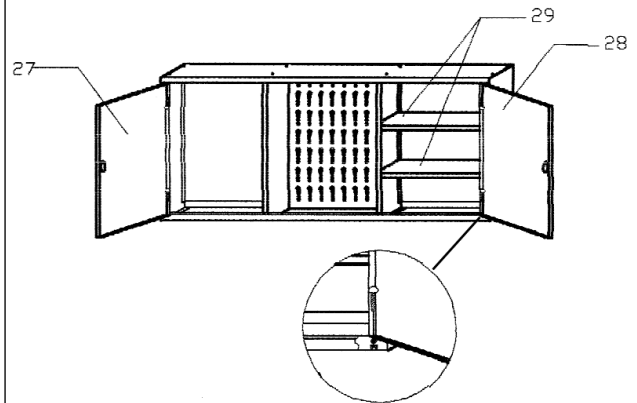

STEP 16. Insert internal shelves (29) as in step 5 except that the shelves are only held in by the shelf support slots, so they can be taken out or put in quickly. Attach the cupboard doors (27, 28) as in step 10 by putting screws through the top and bottom panels of the cabinet and fixing with a nut.

17

STEP 17. When mounting the cabinet onto a wall make sure that it is of sound construction and that the securing points will hold the stain of the cabinet when in use. Ensure that the fixings being used are appropriate and strong enough to hold the weight of the cabinet.

Parts support is available for this product. To obtain a parts listing and/or diagram, please log on to www.sealey.co.uk, email sales@sealey.co.uk or phone 01284 757500.

NOTE: It is our policy to continually improve products and as such we reserve the right to alter data, specifications and component parts without prior notice.
IMPORTANT: No liability is accepted for incorrect use of product. **WARRANTY:** Guarantee is 12 months from purchase date, proof of which will be required for any claim. **INFORMATION:** Call us for a copy of our latest catalogue on 01284 757525 and leave your full name and address including your postcode.



POWER PRODUCTS

Sole UK Distributor
Sealey Group,
Bury St. Edmunds, Suffolk.



01284 757500



01284 703534



www.sealey.co.uk



sales@sealey.co.uk