



# 50KG CAPACITY ADJUSTABLE-HEIGHT MOBILE WORKSTATION

MODEL NO: AP200.V3

Thank you for purchasing a Sealey product. Manufactured to a high standard, this product will, if used according to these instructions and maintained properly, give you years of trouble free performance.

**IMPORTANT: PLEASE READ THESE INSTRUCTIONS CAREFULLY. NOTE THE SAFE OPERATIONAL REQUIREMENTS, WARNINGS & CAUTIONS. USE THE PRODUCT CORRECTLY AND WITH CARE FOR THE PURPOSE FOR WHICH IT IS INTENDED. FAILURE TO DO SO MAY CAUSE DAMAGE AND/OR PERSONAL INJURY AND WILL INVALIDATE THE WARRANTY. KEEP THESE INSTRUCTIONS SAFE FOR FUTURE USE.**



Refer to Instruction Manual

## 1. SAFETY

- WARNING!** Thoroughly read and understand the provided product manual before attempting to use this product.
- WARNING!** Use workstation on level and solid ground, preferably concrete.
- WARNING! DO NOT** stand on this product, or attempt to ride on it. You may fall, which could lead to personal injury.
- WARNING! DO NOT** alter this product in any way. Any added material or components may imbalance the tray, which could lead to property damage and personal injury.
- WARNING! DO NOT** alter this product in any way. Any added material or components may imbalance the tray, which could lead to property damage and personal injury.
- WARNING!** Be mindful of sharp edges/welds while assembling, and operating workstation. Always wear safety gloves and appropriate safety equipment.
- WARNING! DO NOT** exceed weight capacity (see product specifications). This could lead to product failure and personal injury while working with tools and equipment.
- Locate workstation in a suitable working area.
- Keep the work area clean, uncluttered and ensure there is adequate lighting.
- Keep the workstation clean and tidy in accordance with good workshop practice.
- Keep children and unauthorised persons away from working area.
- Ensure that fixings have been securely tightened before use.
- DO NOT** use the workstation for any purpose other than that for which it is designed.
- DO NOT** attempt to transport heavy loads on the workstation.

## 2. INTRODUCTION

Table is fully adjustable in height. Features four compartments, one large for main workpiece and three equal sized smaller sections for accessories. EVA lining on the table helps prevent damage to the unit and workpiece. Suitable for use in workshops and warehouses. Supplied with four castor wheels.

## 3. SPECIFICATION

Model no:	AP200.V3
Minimum Height:	875mm
Maximum Height:	1235mm
Table Size (W x D):	745 x 512mm
Capacity:	50kg

## 4. ASSEMBLY

- 4.1. Remove all contents from the outer box and reference the parts list to ensure that all parts are present.
- 4.2. Fasten (2) Castor wheels (I) to each Base Strut (G & F). Ensure that the Castor wheels (I) is fully inserted into each square slot on the Base Struts (G & F).
- 4.3. Insert Large Plastic inserts (H) into the end caps of the Extended Base Strut (G) and base strut (F).
- 4.4. Align the base plate of the Lower Support Column (J) to the holes on the Base Strut (F). Fasten securely using the M8 x 16 Hex Bolt (L).
- 4.5. Slide the Extended Base Strut (G) into the Lower Support Column (J). Fasten together using the M8 x 16 Hex Bolts (L).
- 4.6. Lay the Top Tray (A) upside down, onto a clean protected surface. Attach the mounting bracket of the Upper Support Column (D) to the bottom of the Tray (A) using the M8 x 16 Hex Bolts (L).
- 4.7. Slide the completed Upper Assembly into the top of the Lower Support Column (J), and secure at the desired height using the Height Adjustment Thumb Screw (E).
- 4.8. Place EVA Mats (K) into Tray (A).
- See diagram and parts list on the next page for build reference.

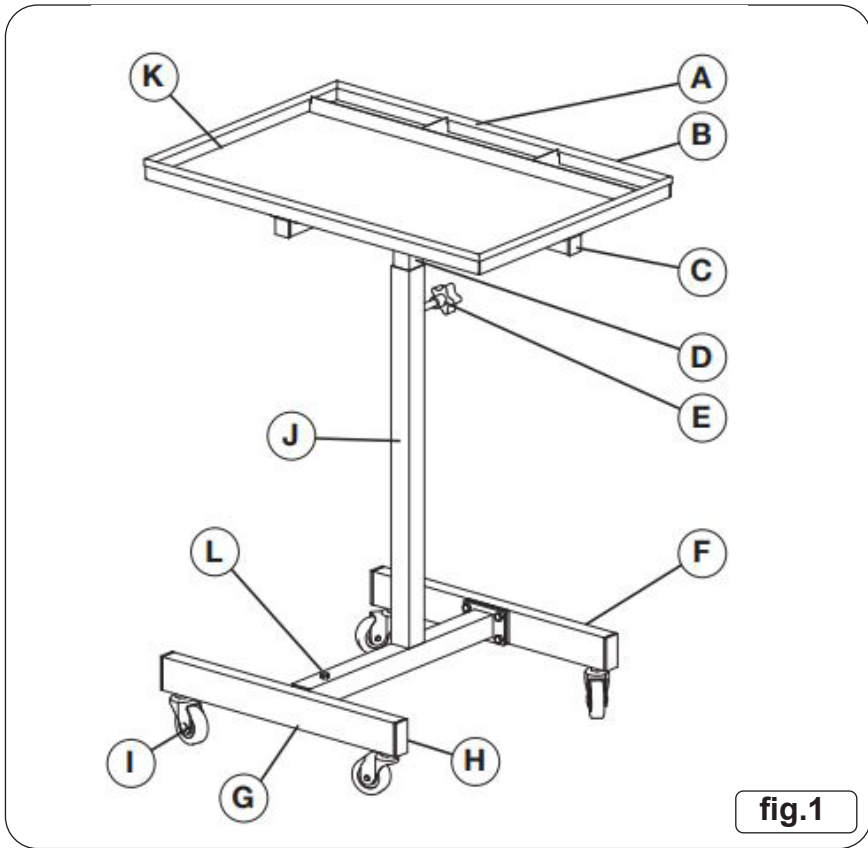

fig.1

PARTS LIST		
Figure	Description	Qty
A	Tray	1
B	Protective Rubber Bumper	1
C	Small Plastic Insert	4
D	Upper Support Column	1
E	Height Adjustment Thumb Screw	1
F	Base Strut	1
G	Extended Base Strut	1
H	Large Plastic Insert	4
I	Castor Wheel	4
J	Lower Support Column	1
K	EVA Mats	4
L	M8 x 16 hex Bolt	9

SUGGESTED TOOLS FOR ASSEMBLY	
1.	Metric Socket Set and Ratchet
2.	Combination Wrench Set
3.	Adjustable Wrench

## 5. OPERATION

- ❑ **WARNING! DO NOT** extend the table beyond the extension warning line located on the table pole. See fig.2.
- 5.1. To adjust the height of the workstation firstly support the table top to prevent it from dropping, then turn the Thumb Screw (E) anticlockwise to loosen. Turn Thumb Screw clockwise to tighten once table top is adjusted to the correct height.
- 5.2. When positioning the table next to or over painted or 'valuable' surfaces ensure they are covered by protective non-scratch covers.

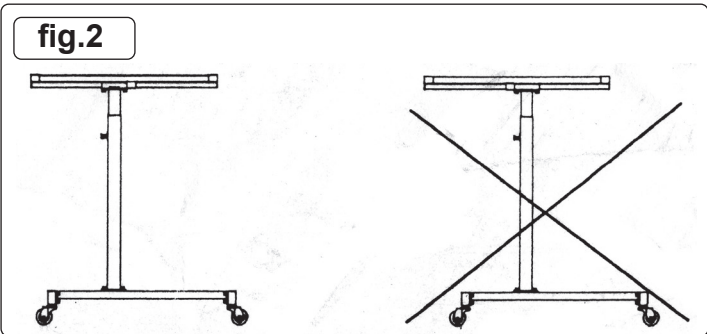

## 6. STORAGE

- ✓ Lower the tray to the lowest height setting for storage.
- ✓ Always store this product on a clean, level surface. **DO NOT** store near flammable materials.

**ENVIRONMENT PROTECTION**

Recycle unwanted materials instead of disposing of them as waste. All tools, accessories and packaging should be sorted, taken to a recycling centre and disposed of in a manner which is compatible with the environment. When the product becomes completely unserviceable and requires disposal, drain any fluids (if applicable) into approved containers and dispose of the product and fluids according to local regulations.



**NOTE:** It is our policy to continually improve products and as such we reserve the right to alter data, specifications and component parts without prior notice. Please note that other versions of this product are available. If you require documentation for alternative versions, please email or call our technical team on [technical@sealey.co.uk](mailto:technical@sealey.co.uk) or 01284 757505.

**IMPORTANT:** No Liability is accepted for incorrect use of this product.

**WARRANTY:** Guarantee is 12 months from purchase date, proof of which is required for any claim.