

Thank you for purchasing a Sealey product. Manufactured to a high standard this product will, if used according to these instructions and properly maintained, give you years of trouble free performance.



IMPORTANT: PLEASE READ THESE INSTRUCTIONS CAREFULLY. NOTE THE SAFE OPERATIONAL REQUIREMENTS, WARNINGS & CAUTIONS. USE THE PRODUCT CORRECTLY AND WITH CARE FOR THE PURPOSE FOR WHICH IT IS INTENDED. FAILURE TO DO SO MAY CAUSE DAMAGE AND/OR PERSONAL INJURY AND WILL INVALIDATE THE WARRANTY. PLEASE KEEP INSTRUCTIONS SAFE FOR FUTURE USE.

1. SAFETY INSTRUCTIONS

1.1 GENERAL SAFETY

- ☐ **WARNING!** Ensure Health & Safety, local authority, and general workshop practice regulations are adhered to when using this bench.
- ✓ Locate bench in a suitable working area.
- ✓ Keep the work area clean, uncluttered and ensure there is adequate lighting.
- ☐ **WARNING!** Use bench on level and solid ground, preferably concrete. *Avoid tarmacadam since the bench may sink into the surface.*
- ✓ Keep the bench clean and tidy in accordance with good workshop practice.
- ✓ Keep children and unauthorised persons away from the working area.
- ☐ **WARNING!** This bench is not electrically insulated and is therefore not suitable for electrical repairs of any sort.
- x **DO NOT** use the bench for any purpose other than that for which it is designed.
- x **DO NOT** undertake work on the bench without the workpiece being adequately secured.
- x **DO NOT** use the bench out of doors.
- x **DO NOT** get the bench wet or use in damp or wet locations or areas where there is condensation.
- x **DO NOT** clean the bench with any solvents which may damage the paint surface.

2. CONTENTS

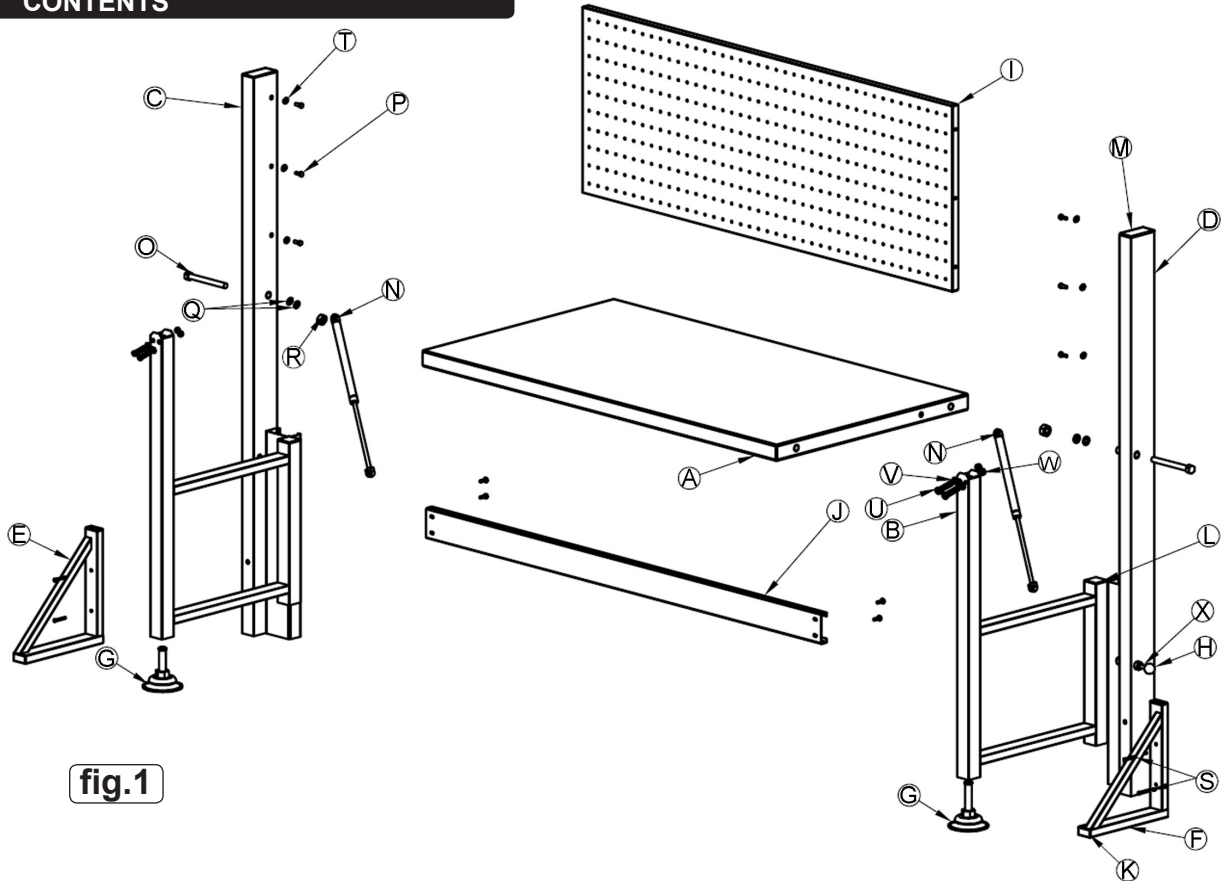

fig.1

Ref.	Item	Qty.
A	Worktable	1
B	Movable Leg	2
C	Main Support Leg (L)	1
D	Main Support Leg (R)	1
E	Triangle Assist Leg (L)	1
F	Triangle Assist (R)	1
G	Adjustable Feet	2
H	Lock Pin	1

Ref.	Item	Qty.
I	Pegboard	1
J	Cross Beam	1
K	Small Plastic Insert	4
L	Medium Plastic Insert	4
M	Large Plastic Insert	2
N	Gas Strut	2
O	M12x100 Bolt	2
P	M6x16 Bolt	10

Ref.	Item	Qty.
Q	M12 Flat Washer	2
R	M12 Nylon Nut	2
S	M6x35 Bolt	4
T	M6 Plastic Washer	12
U	M8x70 Bolt	4
V	M8 Spring Washer	4
W	M8 Nut	4
X	Spring Pin	1

3. ASSEMBLY

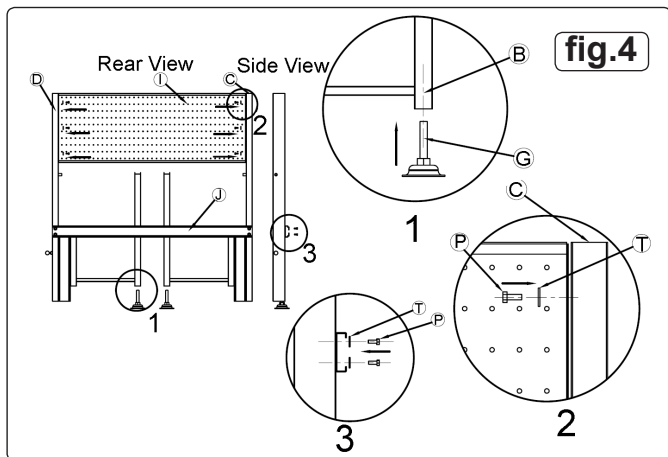

- 3.1 Insert the adjustable workbench feet into the folding legs.
- 3.2 Attach the peg board to the two main support legs using the hex bolts and washers (T, P)
- 3.3 Secure the main cross beam (J) to the two main support legs using the hex bolts and washers (T, P)

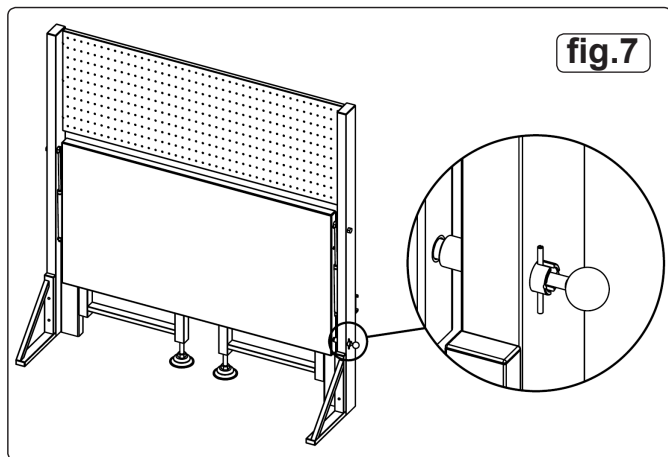

- 3.8 To stow table remove the bolts securing the worktable to the folding legs. Adjust the feet, to allow movement of the folding legs. Fold the legs back and push the worktable down into the vertical position. Twist the lock pin and ensure it locks the worktable in place.

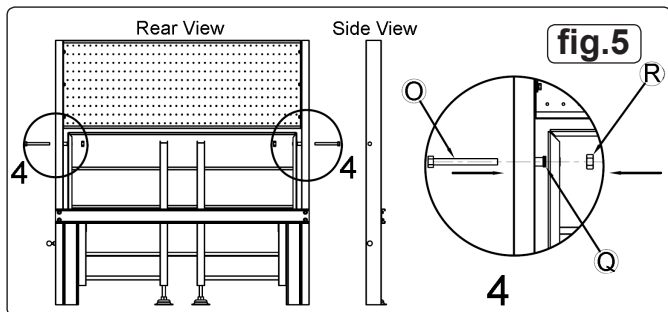

- 3.4 Attach the worktable to the two main support legs using the two large bolts (O) and washers (Q). Secure with nut (R).

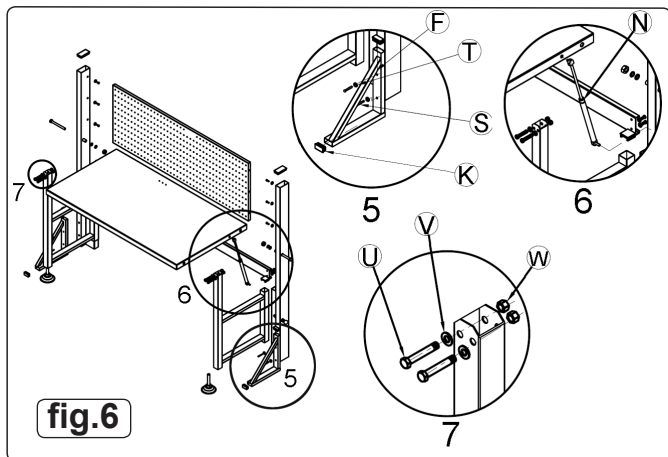

- 3.5 Attach the triangular support legs to the two main support legs using bolt (S) and washers (T). Cap the ends with plastic inserts (K).
- 3.6 Screw the gas struts into the side of the worktable and the main supporting legs.
- 3.7 Swing out the folding legs and rest the worktable on top. Using two long bolts (U), washers (V), and nuts (W) secure the worktable to the legs.

NOTE: It is our policy to continually improve products and as such we reserve the right to alter data, specifications and component parts without prior notice.

IMPORTANT: No liability is accepted for incorrect use of product.

WARRANTY: Guarantee is 12 months from purchase date, proof of which will be required for any claim.

INFORMATION: For a copy of our latest catalogue and promotions call us on 01284 757525 and leave your full name and address, including postcode.



Sole UK Distributor
Sealey Group,
Bury St. Edmunds, Suffolk.

01284 757500
01284 703534

www.sealey.co.uk
sales@sealey.co.uk