

Thank you for purchasing a Sealey product. Manufactured to a high standard this product will, if used according to these instructions and properly maintained, give you years of trouble free performance.

**IMPORTANT PLEASE READ THESE INSTRUCTIONS CAREFULLY. NOTE THE SAFE OPERATIONAL REQUIREMENTS, WARNINGS, AND CAUTIONS. USE THIS PRODUCT CORRECTLY AND WITH CARE, FOR THE PURPOSE FOR WHICH IT IS INTENDED. FAILURE TO DO SO MAY CAUSE DAMAGE AND/OR PERSONAL INJURY AND WILL INVALIDATE THE WARRANTY.**

### 1. SAFETY INSTRUCTIONS

- **WARNING! Ensure Health and Safety, local authority and general workshop practice regulations are adhered to when using tools and equipment.**
- × **DO NOT** use if damaged.
- ✓ Maintain calliper in good and clean condition for best performance.
- ✓ Keep the work area clean, uncluttered and ensure there is adequate lighting.
- ✓ Keep children and unauthorised persons away from the work area.
- × **DO NOT** use the calliper for any purpose other than for which it is designed.
- × **DO NOT** get calliper wet or use in damp or wet locations, or areas where there is condensation. Keep calliper clean and dry using a dry cotton cloth only.
- × **DO NOT** dip or submerge the calliper in any type of liquid.
- × **DO NOT** expose calliper to bright sunlight or dust.
- × **DO NOT** disassemble. The calliper must be checked by qualified service personnel only.
- × **DO NOT** apply any voltage to the calliper i.e. with an electric marker pen.
- ✓ The calliper is a precision instrument, treat with care, avoid using force and do not subject to knocks or shocks.
- ✓ Use in reasonably constant temperature conditions of approximately 20°C.
- ✓ Take particular care not to damage or scratch the scale surface.
- ✓ When not in use, **turn off** and store calliper in a safe, dry, childproof location.

### 2. INTRODUCTION & SPECIFICATION

Hardened and tempered stainless steel dual powered digital calliper with satin finish. Solar powered but also with additional battery cell (CR2016). When light is above 200LUX the solar panel will provide the power and below 200LUX the power will be provided by the battery. Large LCD display for ease of reading. Metric and Imperial calibration with conversion between the two. Zero setting control allows comparative measurement. Supplied in storage case.

Range . . . . . 0-150mm / 0-6"  
 Resolution . . . . . 0.01mm / 0.0005"  
 Accuracy . . . . . 0.03mm / 0.001"  
 Cell Qty x Type . . . . . 1 x CR2016

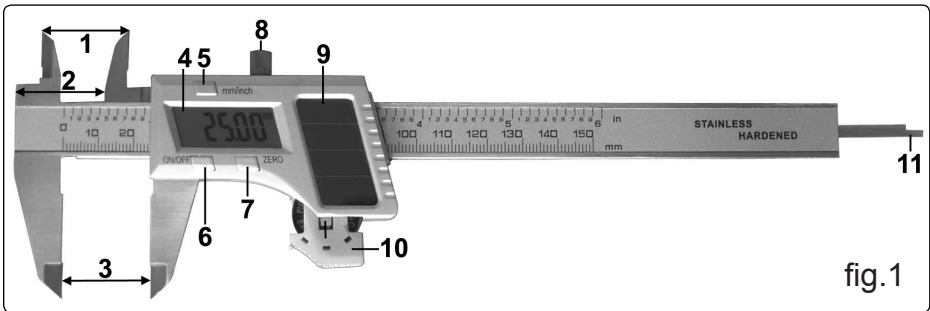

- |                              |  |                          |
|------------------------------|--|--------------------------|
| 1 - Internal Measuring Faces | 5 - Metric (mm)/Imperial (inch) Button | 9 - Solar Panel          |
| 2 - Step Measuring Faces     | 6 - On/Off Button                      | 10 - Battery Compartment |
| 3 - External Measuring Faces | 7 - Zero Button                        | 11 - Depth Gauge         |
| 4 - LCD                      | 8 - Lock Screw                         |                          |

### 3. OPERATION

☐ **WARNING!** Ensure that you have read and understood Section 1 safety instructions before commencing.

- 3.1 Ensure all measuring surfaces are clean and then turn on calliper by pressing on/off control. Wait at least one second before use.
- 3.2 Loosen locking screw and close the calliper; if the LCD does not show zero when closed, reset by pressing the zero button.
- 3.3 Select inch or mm units, with the metric/imperial button. Check that the display shows the required units.
- 3.4 Measurements will now be shown directly on the LCD.
- 3.5 A new zero may be obtained, at any open position of the calliper, by pressing the zero button.
- 3.6 When finished close the calliper and switch off, replace the calliper into its storage box.  
**If the display fails to alter when the slide is moved, remove the battery - wait at least 30 seconds and then refit the battery.**

### 4. BATTERY FITTING

A flashing display indicates that the battery is exhausted - replace as follows:

- 4.1 Switch off and then remove battery holder (fig.1) by sliding outwards, remove the battery holder and flip over as in fig.2.
- 4.2 Remove exhausted battery and fit replacement with positive facing downwards, see fig.3. Flip battery holder over and slide holder back into the calliper, see fig.1.
- 4.3 Dispose of old battery in a safe and approved manner. **Do not burn.**

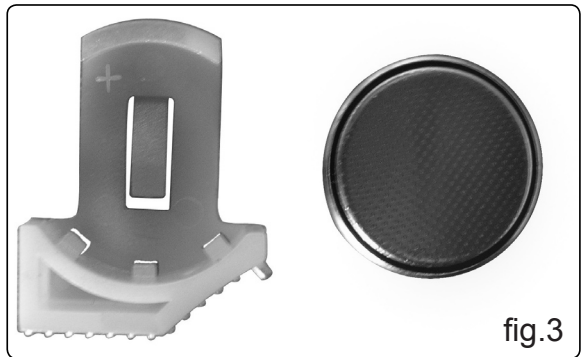

#### Environmental Protection.



Recycle unwanted materials instead of disposing of them as waste. All tools, accessories and packaging should be sorted, taken to a recycle centre and disposed of in a manner which is compatible with the environment.



When the product is no longer required, it must be disposed of in an environmentally protective way. Do not incinerate battery as it may explode when exposed to fire. Do not attempt to open battery.



**Battery Removal** - Slide out the battery holder and remove the exhausted battery. Dispose of according to local authority guidelines.

**NOTE:** It is our policy to continually improve products and as such we reserve the right to alter data, specifications and component parts without prior notice.

**IMPORTANT:** No liability is accepted for incorrect use of this product.

**WARRANTY:** Guarantee is 12 months from purchase date, proof of which will be required for any claim.

**INFORMATION:** For a copy of our catalogue and latest promotions call us on 01284 757525 and leave your full name, address and postcode.



**Sole UK Distributor**  
Sealey Group,  
Bury St. Edmunds, Suffolk.



01284 757500



01284 703534



[www.sealey.co.uk](http://www.sealey.co.uk)



[sales@sealey.co.uk](mailto:sales@sealey.co.uk)

AK9625EV | Issue No: 15/07/09