



INSTRUCTIONS FOR:

OIL DRAINER UNITS

MODEL NO'S: **AK457D, AK450DX**

Thank you for purchasing a Sealey product. Manufactured to a high standard, this product will, if used according to these instructions and maintained properly, give you years of trouble free performance.

IMPORTANT: PLEASE READ THESE INSTRUCTIONS CAREFULLY. NOTE THE SAFE OPERATIONAL REQUIREMENTS, WARNINGS & CAUTIONS. USE THE PRODUCT CORRECTLY AND WITH CARE FOR THE PURPOSE FOR WHICH IT IS INTENDED. FAILURE TO DO SO MAY CAUSE DAMAGE AND/OR PERSONAL INJURY AND WILL INVALIDATE THE WARRANTY. KEEP THESE INSTRUCTIONS SAFE FOR FUTURE USE.



Refer to Instruction Manual



Wear Eye Protection



Wear Protective Gloves

1. SAFETY

- ✓ Replace damaged parts. Use genuine parts only. Non authorised parts may be dangerous and will invalidate the warranty.
- ✓ Keep the drainer clean and in good condition for best and safest performance.
- ✓ Wear appropriate protective clothing.
- ✓ Use drainer in an appropriate working area for its function. Keep area clean and tidy and free from unrelated materials and ensure there is adequate lighting.
- ✓ Ensure the floor is not slippery and wear non slip shoes.
- ✓ Keep children and unauthorised persons away from the working area.
- ✓ Dispose of waste liquids in accordance with local authority regulations.
- ☐ **WARNING! DO NOT** allow uncontrolled discharge of fluids thus polluting the environment.
- ✗ **DO NOT** position drainer in such a way that it will cause potential hazards when moving, holding for draining or storing.
- ▲ **IMPORTANT:** AK450DX must be used in conjunction with a wall mounted air pump, model no: AK450DP in order to discharge waste oil (not supplied with this unit).

2. INTRODUCTION

AK457D: Steel fabricated 75ltr reservoir and telescopic steel funnel fitted with grid filter. Gravity drain using brass tap on rear of unit. Includes full drum indicator.

AK450DX: 75ltr reservoir and telescopic funnel fitted with grid filter. Fitted with female dry-fit coupling for connection to Model no: AK450DP Pump-Away Station. Includes full drum indicator.

3. SPECIFICATION

Model No:	AK457D	AK450DX
Maximum Capacity:	75ltr	75ltr
Minimum Height:	1180mm	1180mm
Maximum Height:	1750mm	1750mm
Length:	590mm	590mm
Width:	600mm	600mm
Discharge:	Gravity	Air Pump
Nett Weight:	29kg	29kg

4. ASSEMBLY

- 4.1. Unscrew the complete axle assembly from the transportation position. Use the nuts, bolts, and washers that are provided to fit the axle assembly and position the castor wheels as illustrated in the parts diagram.
- 4.2. Screw the drainage tube (item 3) into the collection bowl (item 2).
- 4.3. Introduce the drainage tube through the height adjustment adaptor into the reservoir and tighten the scalloped hand wheel (item 4).
- 4.4. Place the filter into the collection bowl (item 1).

5. OPERATION

5.1. Collection of waste oil

- 5.1.1. If unit has been used to drain a previous vehicle, check the oil level indicator float to ensure there is sufficient remaining capacity left before you use the unit. If model AK457D is empty, ensure the evacuation tap is closed before you use the unit.
- 5.1.2. Place the unit under the raised vehicle and adjust the collection bowl to the desired height and tighten the scalloped hand wheel of the adjustable height adaptor.

5.2. Evacuation of waste oil from unit. **WARNING! ensure all waste is disposed of in accordance with local regulations.**

- 5.2.1. AK457D position the gravity drain tap over a suitable outlet and open the tap.
- 5.2.2. AK450DX take the discharge hose of wall mounted pump unit AK450DP and connect the female coupling to the male coupling of the pan unit and evacuate waste accordingly.

6. MAINTENANCE

- 6.1. Keep the collection bowl and unit clean and ensure there are no blockages in the evacuation outlets.
- 6.2. Oil wheels if necessary
- 6.3. When not in use store the unit in a safe, dry, childproof area.

7. PARTS LIST

Item	Part No	Description
1	179.04467 - FB04F	Collection bowl filter
2	179.04492 - FJJ2A	Collection bowl
3	179.87065	Drainage tube
4	179.04395	1" Female Connector
5	179/04464	Scalloped hand wheel
6	179/04563	Reservoir
7	179/04357	M10 x 55 Hexagon bolt, DIN931
8	179/03858	Washer
9	179.87125 - KI 4F	Spacer
10	179.04332	Castor
11	179/03311	M10 Nut, DIN 985
12	179.04562	Sleeve
13	179.04356	M10 x 25 Hexagon bolt, DIN933
14	179.04462	Axle
15	179.04333	Wheel
16	179.19786	Gravity drain valve Model AK457D
	179/19774	Male quick release connector Model AK450DX
	179/04398	Float indicator

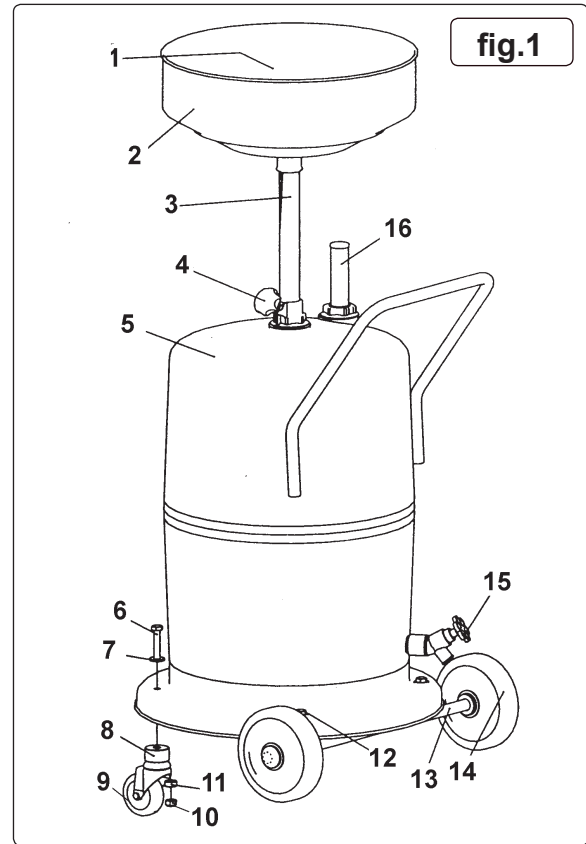

Environmental Protection



Recycle unwanted materials instead of disposing of them as waste. All tools, accessories and packaging should be sorted, taken to a recycling centre and disposed of in a manner which is compatible with the environment. When the product becomes completely unserviceable and requires disposal, drain off any fluids (if applicable) into approved containers and dispose of the product and the fluids according to local regulations.

NOTE: It is our policy to improve products continually and as such we reserve the right to alter data, specifications and component parts without prior notice.

IMPORTANT: No liability is accepted for incorrect use of this product.

WARRANTY: Guarantee is 12 months from purchase date, proof of which will be required for any claim.

SEALEY

Sole UK Distributor, Sealey Group,
Kempson Way, Suffolk Business Park,
Bury St. Edmunds, Suffolk,
IP32 7AR



01284 757500



www.sealey.co.uk



01284 703534



sales@sealey.co.uk