

Thank you for purchasing a Sealey Product. Manufactured to a high standard this product will, if used according to these instructions and properly maintained, give you years of trouble free performance.



IMPORTANT: PLEASE READ THESE INSTRUCTIONS CAREFULLY. NOTE THE SAFE OPERATIONAL REQUIREMENTS, WARNINGS AND CAUTIONS. USE THIS PRODUCT CORRECTLY AND WITH CARE FOR THE PURPOSE FOR WHICH IT IS INTENDED. FAILURE TO DO SO MAY CAUSE DAMAGE AND/OR PERSONAL INJURY AND WILL INVALIDATE THE WARRANTY. PLEASE KEEP INSTRUCTIONS SAFE FOR FUTURE USE.

1. SAFETY INSTRUCTIONS

1.1. GENERAL

- ✓ Ensure the spotlight is correctly charged before initial use.
- ✓ When fully charged, spotlight must not be used continuously for more than 20 minutes. To do so may damage the spotlight.
- WARNING!** The lens becomes very hot during operation.
- DO NOT** cover or block the lens during use.
- DO NOT** turn the spotlight on when it is being re-charged.
- DO NOT** shine directly into your, other person's or animal's eyes.
- DO NOT** stand the spotlight near any surface or item that may be adversely effected by the heat emitted by the lens.
- DO NOT** allow children to use the spotlight.
- DO NOT** handle or move the spotlight whilst it is being charged.
- DO NOT** use the spotlight if you suspect that the battery or the spotlight casing is damaged.
- DO NOT** handle the bulb with your fingers. Use a soft lint-free cloth.
- ✓ Ensure that correctly rated battery and bulb are used for replacements.
- ✓ When not in use store the spotlight in a safe, dry, childproof location.

1.2. BATTERY SAFETY

DANGER! BE AWARE, LEAD-ACID BATTERIES MAY BE DANGEROUS IF NOT HANDLED WITH CARE AND ACCORDING TO THESE INSTRUCTIONS.

- ✓ Before exposing the battery for replacement, remove personal metallic items such as rings, bracelets, necklaces and watches. A lead-acid battery can produce a short-circuit current high enough to weld a ring to metal, which would cause severe burns.
- DO NOT** smoke or allow a spark or flame in the vicinity of battery.
- ✓ Ensure the charger is switched off and disconnected from the spotlight before attempting to open the lamp unit.
- ✓ If the battery or wire terminals are corroded or dirty, clean them before replacing battery.
- DO NOT** dis-assemble the battery for any reason.
- WARNING! DO NOT** allow metal tools to touch both battery terminals simultaneously. Arcing or short circuit will result.
- DO NOT** allow battery wires to touch each other or to make contact with any other metallic part.
- DO NOT** cross-connect wires to the battery as this will damage the unit. Ensure positive (+) (RED) is to positive and negative (-) BLACK is to negative.
- DO NOT** leave battery in a discharged state, recharge battery immediately. If the lantern is not in use, recharge the battery every three months. Dispose of the old battery in accordance with local authority battery regulations. **DO NOT** dispose of with regular refuse.

1.3. ELECTRICAL SAFETY.

USE ONLY THE SUPPLIED CHARGER PLUG FOR CONNECTING SPOTLIGHT TO THE POWER SUPPLY. ONLY USE THE SUPPLIED ADAPTOR FOR CONNECTING TO A VEHICLE 12V SOCKET.

- WARNING!** It is the user's responsibility to read, understand and comply with the following electrical instructions with respect to the charger plug: You must ensure the risk of electric shock is minimised by the installation of appropriate safety devices. An RCCB (Residual Current Circuit Breaker) should be incorporated in the main distribution board. We also recommend that an RCD (Residual Current Device) is used with all electrical products, particularly portable equipment which is plugged into an electrical supply not protected by an RCCB.

You must also read and understand the following instructions concerning electrical safety.

1.3.1. The Electricity At Work Act 1989 requires all portable electrical appliances, if used on business premises, to be tested by a qualified electrician, using a Portable Appliance Tester (PAT), at least once a year.

1.3.2. The Health & Safety at Work Act 1974 makes owners of electrical appliances responsible for the safe condition of the appliance and the safety of the appliance operator. **If in any doubt about electrical safety, contact a qualified electrician.**

1.3.3. You must ensure that you:

- ✓ Inspect the charger plug, cable and connector for wear and damage to ensure items are safe before connecting to the mains power supply. If worn or damaged **DO NOT** use.
- ✓ Check cables are always protected against short circuit and overload.
- ✓ Important: Check that the voltage marked on the charger plug is the same as the power supply to be used.
- ✓ Uncoil the cable between charger and the spotlight.
- DO NOT** pull the charger plug from the mains socket by the lead.
- DO NOT** use any other type of charger with this product.
- DO NOT** place the connector into any area of the spotlight except the correct jack inlet socket.
- DO NOT** try to take the charger plug apart.
- DO NOT** use the charger plug to charge or power any other electrical item.
- DO NOT** get the charger wet, or use in wet, damp conditions (for indoor use only).
- WARNING! NEVER** substitute a standard 13 amp 3 pin plug, or any other type of plug, for the charger plug.

2. INTRODUCTION & OPERATION

2.1. INTRODUCTION

Weatherproof composite spotlight with swivel handle feature allowing pistol grip or carry handle operation. Integral foot doubles as carry handle when used in pistol grip mode. Ø110mm Lens with halogen bulb produces 1-million candle power of intense white light, suitable for a variety of industrial, domestic and leisure applications. Supplied with sealed 6Volt 4Ah battery, in-vehicle charger and 230 - 6Volt battery charger pack.

Output 1 000 000 candle power
Lens Diameter 110mm
Cell Type 6V - 4.0Ah Rechargeable

2.2. OPERATION

☐ **WARNING! Ensure you read and understand safety instructions before use.**

Reminder: These spotlights are designed for intermittent use only. Continuous use may damage the unit.

1. Charge the battery before use. **IMPORTANT: Turn off spotlight while charging. Failure to do so will damage the charger plug/vehicle plug.**
2. Turn spotlight 'On' and 'Off' by the switch on the main body.
3. To use as shown in fig.1, press locking button (fig.1.1) and rotate the handle (fig.1.2) anti-clockwise, to grip position. fig.2 shows the arrangement for standing the spotlight on a surface, using the adjustable support.

2.3. BATTERY CHARGING

☐ **WARNING! Ensure you read, understand and apply safety instructions relating to the battery and charger before use.**

2.3.1. Charger plug

1. Plug the charger adaptor (fig.3) into the jack inlet on the spotlight body (fig.2.1) and stand the spotlight in a safe location ready to charge.
2. Ensure the spotlight is turned 'Off' and then plug charger into the mains supply.
3. Allow approximately 15 hours for the initial charge and 10 hours for subsequent charges. When fully charged, switch off the mains supply and unplug the charger. Remove the charger adaptor (fig.3) from the spotlight and seal the jack inlet. The spotlight may now be used.
4. Store the charger in a safe, dry location.

Notes: a) A fully charged battery will last for approximately 40 minutes
b) Do not let the battery fully discharge.

2.3.2. Vehicle plug

1. Ensure spotlight is turned 'Off' and then plug the 12 volt vehicle plug adaptor (fig.4.) into the jack inlet on the spotlight body (fig.2.1). Stand the spotlight in a safe location ready to charge.
2. Insert plug into vehicle cigarette lighter socket. Allow approximately 15 hours for the initial charge and 10 hours for subsequent charges.
3. When fully charged, unplug the adaptor from the vehicle socket and from the spotlight **before** turning the spotlight on.
4. Store the adaptor in a safe, dry location.

NOTE: Charging the spotlight from an 12 volt vehicle socket will drain the vehicle battery, unless the engine is running.

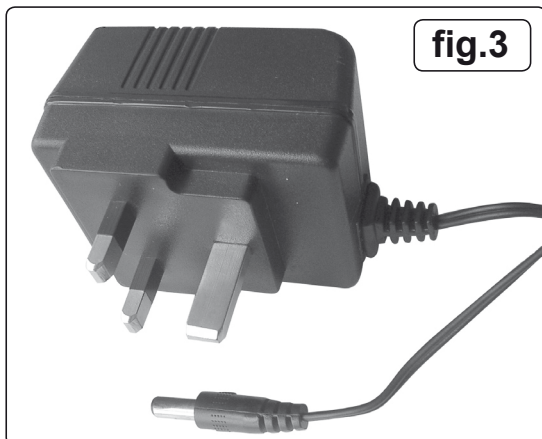

3. MAINTENANCE

3.1. CHANGING THE SPOTLIGHT BULB

- ❑ **WARNING!** Ensure the spotlight is turned off and the lens has cooled prior to changing the bulb.
 1. Undo the spotlight hood (fig.1.H) by turning it anti-clockwise.
 2. Carefully lift the reflector assembly revealing the spring clip (fig.5.1) and the cable connector (fig.5.2).
 3. Disconnect cable (fig.5.3).
 4. Remove the spring clip (fig.5.1).
 5. If unable to remove bulb, first remove screw and nut (fig.5.5)
 6. Pull bulb (fig.5.4) outward from the reflector.
 7. Hold the new bulb with a lint free cloth, (do not handle the bulb), and install by reversing the above procedure.
- ❑ **WARNING! Beware of causing a short circuit.**

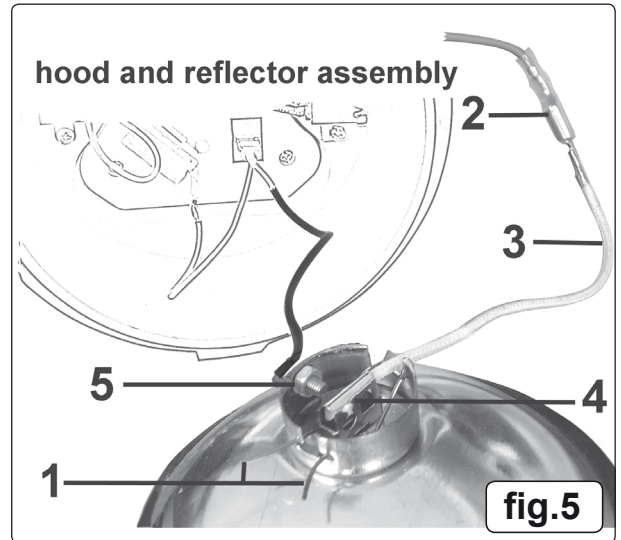

3.2. CHANGING THE BATTERY

- ❑ **WARNING!** Ensure you read, understand and apply safety instructions relating to the battery before changing.
 1. Undo the spotlight hood (fig.1.H) by turning it anti-clockwise.
 2. Carefully lift the hood and reflector assembly.
 3. Remove the screws holding the printed circuit board (fig.6.3)
 4. Disconnect the red and black battery terminal wires removing the black negative wire first (fig.6.2a,2b).
 5. Undo the four battery cover retaining screws (fig.6.1).
 6. Carefully raise the battery cover.
 - ❑ **WARNING! Beware of causing a short circuit.**
 7. Carefully remove the battery.
 8. Replace with genuine Sealey battery and install by reversing the above procedure.
- NOTE:** Take care not to pinch or misconnect any wires.
9. Dispose of old battery in accordance with local authority battery regulations. **DO NOT** dispose of with regular refuse.

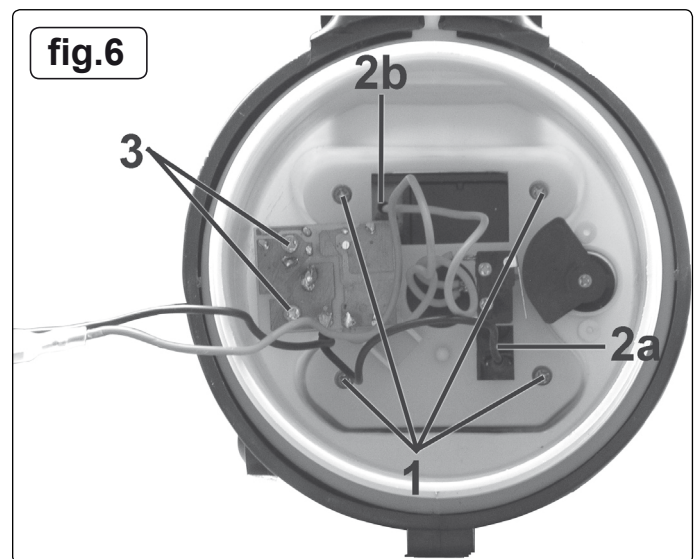

Environmental Protection.



Recycle unwanted materials instead of disposing of them as waste. All tools, accessories and packaging should be sorted, taken to a recycle centre and disposed of in a manner which is compatible with the environment.



When the product is no longer required, it must be disposed of in an environmentally protective way. Contact your local solid waste authority for recycling information.

Battery Removal.



- ❑ **WARNING! Ensure the spotlight is turned off before removing the battery** Refer to Section 3.2 to remove the battery. **Dispose of batteries according to local authority guidelines.**

Under the Waste Batteries and Accumulators Regulations 2009, Jack Sealey Ltd are required to inform potential purchasers of products containing batteries (as defined within these regulations), that they are registered with Valpak's registered compliance scheme. Jack Sealey Ltd's Batteries Producer Registration Number (BPRN) is BPRN00705

NOTE: It is our policy to continually improve products and as such we reserve the right to alter data, specifications and component parts without prior notice.

IMPORTANT: No liability is accepted for incorrect use of this product.

WARRANTY: Guarantee is 12 months from purchase date, proof of which will be required for any claim.

INFORMATION: For a copy of our latest catalogue and promotions call us on 01284 757525 and leave your full name and address, including postcode.



Sole UK Distributor, Sealey Group,
Kempson Way, Suffolk Business Park,
Bury St. Edmunds, Suffolk,
IP32 7AR



01284 757500



www.sealey.co.uk



01284 703534



sales@sealey.co.uk