



INSTRUCTIONS FOR:

DUAL FUSION® PARAFFIN/KEROSENE & DIESEL HEATER 170,000/220,000Btu/hr WITH WHEELS

MODEL No: **AB2200Q**

Thank you for purchasing a Sealey product. Manufactured to a high standard, this product will, if used according to these instructions, and properly maintained, give you years of trouble free performance.



IMPORTANT: PLEASE READ THESE INSTRUCTIONS CAREFULLY. NOTE THE SAFE OPERATIONAL REQUIREMENTS, WARNINGS & CAUTIONS. USE THE PRODUCT CORRECTLY AND WITH CARE FOR THE PURPOSE FOR WHICH IT IS INTENDED. FAILURE TO DO SO MAY CAUSE DAMAGE AND/OR PERSONAL INJURY AND WILL INVALIDATE THE WARRANTY. KEEP THESE INSTRUCTIONS SAFE FOR FUTURE USE.

1. SAFETY



Electrical Hazard



Hot Surface



Unexpected Start Up

1.1. ELECTRICAL SAFETY

- WARNING!** It is the responsibility of the owner and the operator to read, understand and comply with the following:
You must check all electrical products, before use, to ensure that they are safe. You must inspect power cables, plugs, sockets and any other connectors for wear or damage. You must ensure that the risk of electric shock is minimised by the installation of appropriate safety devices. A Residual Current Circuit Breaker (RCCB) should be incorporated in the main distribution board. We also recommend that a Residual Current Device (RCD) is used. It is particularly important to use an RCD with portable products that are plugged into a supply which is not protected by an RCCB. If in any doubt consult a qualified electrician. You may obtain a Residual Current Device by contacting your Sealey dealer.
You must also read and understand the following instructions concerning electrical safety.
- 1.1.1. **The Electricity at Work Act 1989** requires that all portable electrical appliances, if used on business premises, are tested by a qualified electrician, using a Portable Appliance Tester (PAT), at least once a year.
- 1.1.2. **The Health & Safety at Work Act 1974** makes owners of electrical appliances responsible for the safe condition of those appliances and the safety of the appliance operators. If in any doubt about electrical safety, contact a qualified electrician.
- 1.1.3. Ensure that the insulation on all cables and on the appliance is safe before connecting it to the power supply. See 1.1.1. and 1.1.2. and use a Portable Appliance Tester.
- 1.1.4. Ensure that cables are always protected against short circuit and overload.
- 1.1.5. Regularly inspect power supply cables and plugs for wear or damage and check all connections to ensure that none is loose.
- 1.1.6. **Important:** Ensure that the voltage marked on the appliance matches the power supply to be used and that the plug is fitted with the correct fuse - see fuse rating at right.
- 1.1.7. **DO NOT** pull or carry the appliance by the power cable.
- 1.1.8. **DO NOT** pull the plug from the socket by the cable.
- 1.1.9. **DO NOT** use worn or damaged cables, plugs or connectors. Immediately have any faulty item repaired or replaced by a qualified electrician. When a BS 1363/A UK 3 pin plug is damaged, cut the cable just above the plug and dispose of the plug safely.
Fit a new plug according to the following instructions (UK only).
 - a) Connect the **GREEN/YELLOW earth wire to the earth terminal 'E'**.
 - b) Connect the **BROWN live wire to the live terminal 'L'**.
 - c) Connect the **BLUE neutral wire to the neutral terminal 'N'**.d) After wiring, check that there are no bare wires, that all wires have been correctly connected, that the cable outer insulation extends beyond the cable restraint and that the restraint is tight.
Double insulated products, which are always marked with this symbol , are fitted with live (brown) and neutral (blue) wires only. To rewire, connect the wires as indicated above.
DO NOT connect either wire to the earth terminal.
- 1.1.10. Products which require more than 13 amps are supplied without a plug. In this case you must contact a qualified electrician to ensure that a suitably rated supply is available. We recommend that you discuss the installation of an industrial round pin plug and socket with your electrician.
- 1.1.11. If an extension reel is used it should be fully unwound before connection. A reel with an RCD fitted is preferred since any appliance plugged into it will be protected. The cable core section is important and should be at least 1.5mm², but to be absolutely sure that the capacity of the reel is suitable for this product and for others which may be used in the other output sockets, we recommend the use of 2.5mm² section cable.

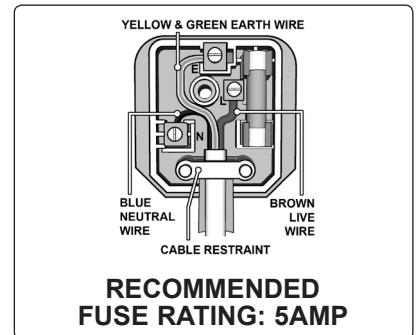

1.2. GENERAL SAFETY

- DANGER!** Risk of carbon monoxide poisoning. Failure to provide proper ventilation could result in serious illness or death.
- ✓ Check that the heater is in sound condition and good working order. *Take immediate action to repair or replace damaged parts.*
- ✓ Use recommended parts only. *Unauthorised parts may be dangerous and will invalidate the warranty.*
- ✓ Only use paraffin, diesel or kerosene to fuel this heater, in accordance with instructions contained in this manual.
- ✓ Locate heater on a level and stable surface.
- WARNING!** Only use heater in well ventilated areas. Ensure continuous ventilation is provided to the heater operating area via windows and doors etc. If people are **not** required to be present in the heated area, the *volume of air to be heated (mtr³)/heat output (kW)* ratio must be at least 10:1 and people must be advised not to remain in the heated area for prolonged periods. If people **are** required to be present in the heated area, the *volume of air to be heated (mtr³)/heat output (kW)* ratio must be at least 30:1. Ventilation must be to the outside of the premises in which the heater is to be operated. **Minimum Ventilation Opening Needed: AB2200Q - 5990cm² (6.5ft²).** The volume concentration of oxygen (O₂) in the heated room, must always remain above 17%.
- WARNING! DO NOT** use the heater near flammable material, liquids, solids, gases or compressed gas cylinders etc.
- x **DO NOT** stand or place **any** object less than 3m from the heater output and keep the heater a minimum of 2m from any walls or objects.
- x **DO NOT** use the heater in closed rooms, living areas, basements or below ground level.

- X **DO NOT** allow untrained persons to operate the heater and **DO NOT** operate the heater without the safety guard.
- X **DO NOT** move or handle the heater when hot, without wearing protective gloves. Never move the heater whilst it is operating.
- X **DO NOT leave the heater unattended for prolonged periods of time when in use.** Switch the heater off and unplug from the mains before leaving work area.
- X **DO NOT** fill the fuel tank whilst the heater is running or still hot. **DO NOT** over-fill the fuel container. Wipe up any spilt fuel immediately.
- X **DO NOT** obstruct the air inlet (rear) and air outlet (front) of the heater and **DO NOT** use duct work in front or at the rear of the heater.
- X **DO NOT** allow children or animals near the heater when in use, or whilst still hot.
- ☐ **WARNING! RISK OF ELECTRIC SHOCK. DO NOT** expose the heater to water spray, rain, dripping water or wind.
- X **DO NOT** operate the heater when you are tired or under the influence of alcohol, drugs or intoxicating medication.
- X **DO NOT** touch the heater outlet when in use, or for a period of time after it's switched off, as these are **VERY** hot and will take time to cool down.
- X **DO NOT** switch the heater off by disconnecting it from the mains. **ALWAYS** set the switch on the burner to the 'OFF' position and allow the cooling cycle to finish, before disconnecting from the mains.
- X **DO NOT** use an external fuel tank. Only use the tank that is fitted to the heater, and only fill it when the heater has cooled down.
- ✓ Ensure that the heater is correctly turned off.
- ✓ When not in use for an extended period, store in a safe, dry area, out of reach of children.

Important: This appliance is not intended for persons (including children) with reduced physical, sensory or mental capabilities, or lack of experience and knowledge, unless they have been given supervision or instruction concerning use of the appliance by a person responsible for their safety. Children should be supervised to ensure that they do not play with the appliance.

2. INTRODUCTION

New design heaters are up to 50% quieter than traditional forced air models. Two heat settings allow for High and Low output enabling maximum fuel efficiency. Proven pump system handles paraffin/kerosene or diesel without any modification and provides a cleaner more efficient combustion. Fitted with top mounted touch pad panel, which allows easy and convenient control over the output and room thermostat temperature. Fitted with many additional features, including digital room temperature (°C) display, code read out, heavy-duty solid wheels, fuel tank gauge and heavy-duty filler cap. Suitable for ventilated areas like warehouses, garages and workshops.

3. SPECIFICATION

Model No:	AB2200Q
Output:	50/65kW
Output:	170,000/220,000Btu/hr
Tank Capacity:	49ltr
Fuel:	Paraffin/Kerosene/Diesel
Supply:	230V-5A
Running Time per Filling(Maximum):	10hrs
Transport Wheels:	Yes
Air Flow:	685cfm
Automatic Shut-Off:	Yes
Heated Area:	44000ft ³
Heated Area:	1250m ³
Weight:	37kg

☐ **WARNING!** *This heater is not suitable for use with Bio-Diesel; use of Bio-Diesel will damage the filter and seals. Damage caused by use of Bio-Diesel will not be covered by warranty.*

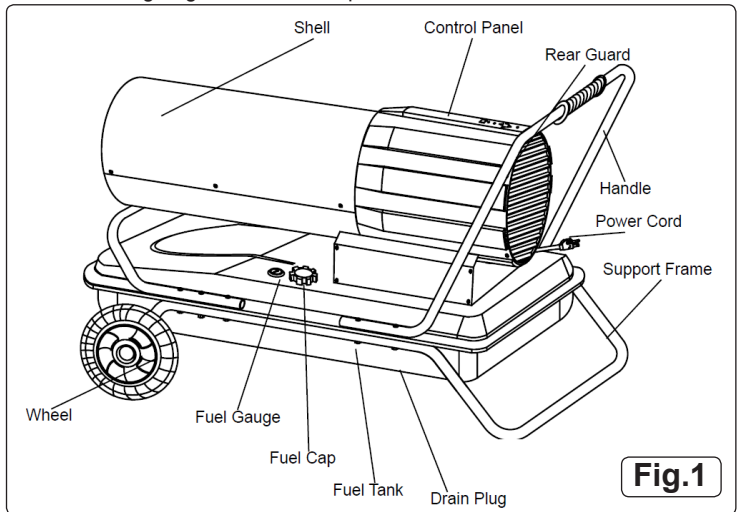

4. ASSEMBLY

- 4.1. Remove the heater and all the packaging from the carton. Note: make sure the axle is removed from the side of the polystyrene packaging.
- 4.2. Tools Required: cross head screwdriver, 8mm open ended spanner, 19mm open ended spanner.
- 4.3. Contents

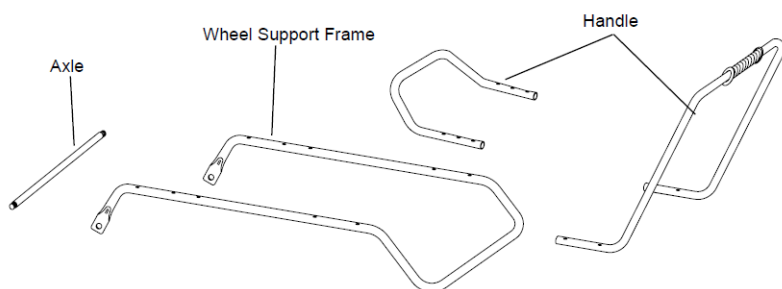
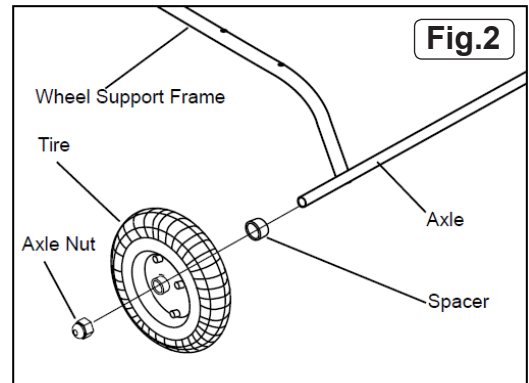
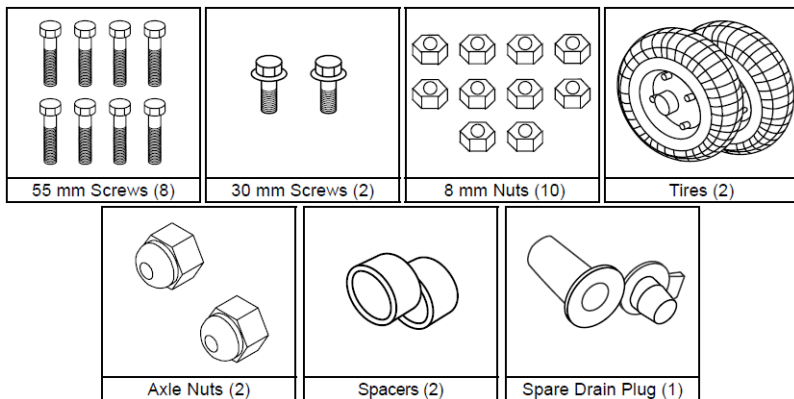

- 4.4. **Refer to fig.2**
Insert axle through holes in wheel support.
- 4.5. Slide the spacers onto the axle, then slide the wheels onto the axle with the air valves facing outwards. Use the axle nuts to hold them in place.
- 4.6. **Refer to fig.3.**
Place heater on wheel support frame and line up holes on the fuel tank lip.
- 4.7. Attach front handle with 4 long (55mm) screws and four nuts, through the second and third holes from the front on both sides of the tank lip and tighten firmly.
- 4.8. Insert two short screws (30mm) through the first hole in the front of the front handle and tank lip. Fit nuts and tighten firmly.
- 4.9. Attach rear handle with 4 long screws (55mm) and four nuts through the first and second hole from the rear on both sides of the tank lip and the wheel support frame and tighten firmly.

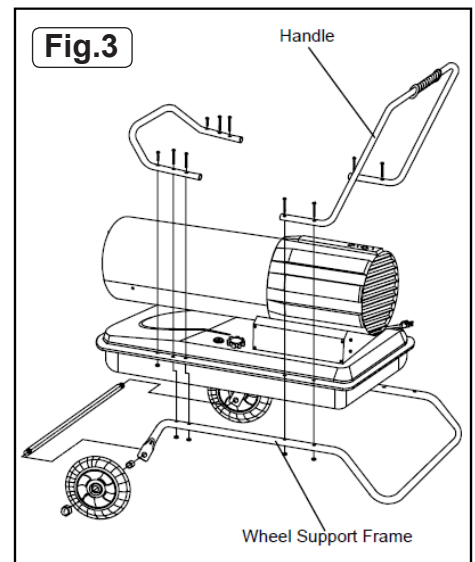

5. OPERATION

- ⚠ **DANGER!** Never refuel this heater while it is hot or operating. Fire or explosion could result. Never fill the fuel tank indoors, only outdoors on a level surface. **DO NOT** overfill the tank.
- ⚠ **WARNING!** Minimum distance from combustibles: Outlet 3 metres, Sides/Top/Rear 2 metres.
- 5.1. **Ventilation**
 - 5.1.1. Risk of indoor air pollution and Carbon Monoxide poisoning. Not for indoor use. Indoor use only permitted for the temporary heating of buildings under construction, alteration or repair.
 - 5.1.2. Always provide a fresh air opening in the heated space. Provide a larger opening if more heaters are being used.
 - 5.1.3. **Minimum Ventilation Opening Needed: AB2200Q - 5990cm² (6.5ft²)**
- 5.2. **Starting the Heater (Ignition) Refer to fig.4**
 - 5.2.1. Fill the tank with kerosene or other approved fuel until the needle on the fuel gauge points to "F".
 - 5.2.2. Replace fuel cap and tighten firmly.
 - 5.2.3. Connect the heater to a mains supply. You must use an extension lead that is at least 3 metres long and of a minimum of 14 AWG rating.
 - 5.2.4. Press the power button to turn the heater on.
 - 5.2.5. Select BTU output setting using BTU HI / LO buttons.
 - 5.2.6. Select desired temperature using temperature HI / LO buttons.
 - 5.2.7. The heater will ignite once the temperature setting is higher than the ambient temperature in the space.
 - Note:** If the heater does not ignite, the thermostat may be set too low. Increase the temperature to a higher setting until the heater ignites.
 - Note:** If the heater does not ignite, press power button to turn off the heater, check steps 1-3 above and press power button to power on the heater. If the heater still does not ignite refer to "Troubleshooting Guide" see section 8.
- 5.3. **Stopping / Restarting the Heater**
 - 5.3.1. To stop the heater, move the power switch to the "Off" position and unplug the mains cable.
 - 5.3.2. To restart the heater wait 10 seconds and follow 5.2. "Starting the Heater" steps.

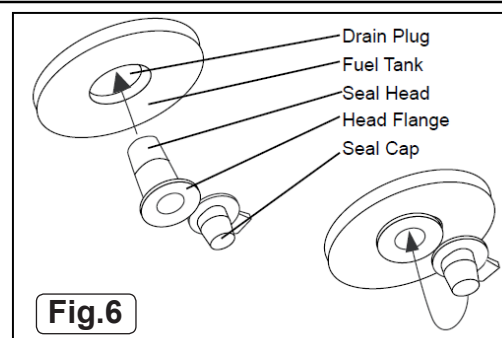
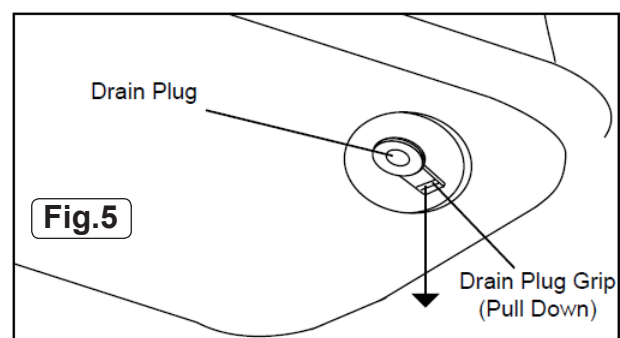
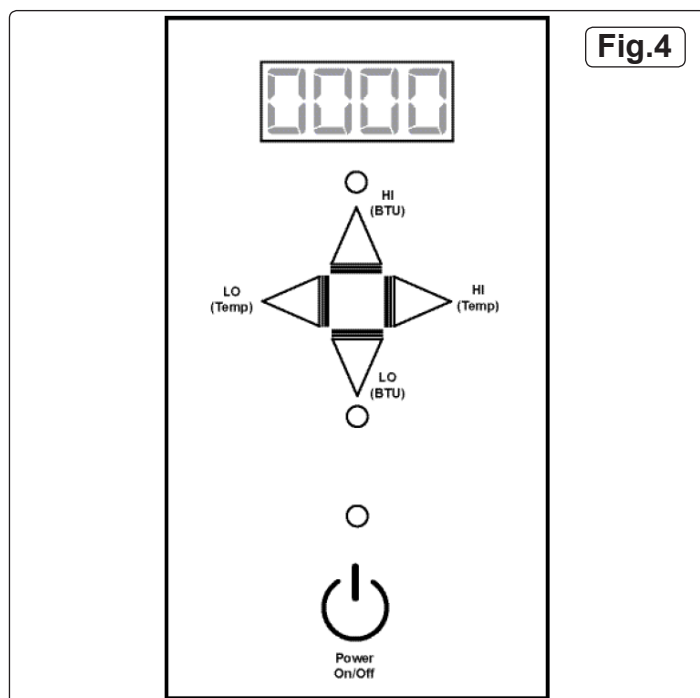

6. MAINTENANCE

6.1. Long Term Storage

- 6.1.1. Drain the fuel in the bottom of the fuel tank.
- 6.1.2. To remove the drain plug, pull the plug grip downward and remove the seal head from the drain hole in the tank. (See fig.5).
- 6.1.3. Using a small amount of kerosene, rinse and swirl the inside of the fuel tank, empty the tank fully.
- 6.1.4. To replace the drain plug; push the drain head fully into the drain hole and secure by pushing the seal cap fully into the head hole. (See fig.6).

6.2. Service

- 6.2.1. **DO NOT** tamper with the unit. Return to a Sealey service agent.

6.3. Maintenance Schedule

- 6.3.1. Fuel/Fuel Tank: flush tank every 200 hours of operation or as needed, (refer to section 6.1). **DO NOT** flush with water, use fresh kerosene only.
- 6.3.2. Fan Blades: Blades should be cleaned at least once per heating season, depending on conditions. Remove all accumulated dust and dirt with a damp cloth, taking care not to bend any of the fan blades. Be sure the blades are dry before restarting the heater. For fan assembly removal see fig.7.
- 6.3.3. Fuel Filter: The fuel filter should be cleaned at least twice per heating season. Clean the filter by rinsing it in clean kerosene. Contaminated fuel could make cleaning the fuel filter necessary immediately. To remove the filter turn the filter 90° anticlockwise.

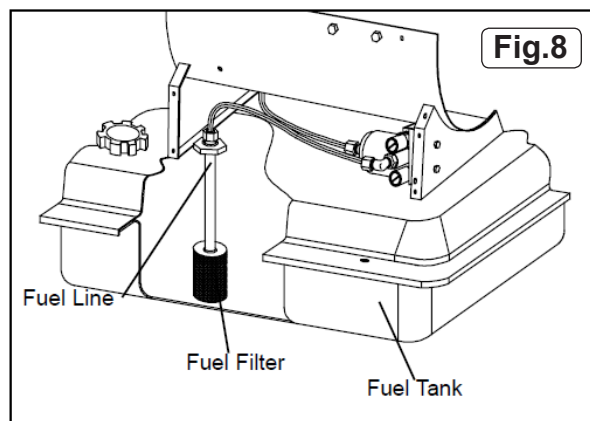
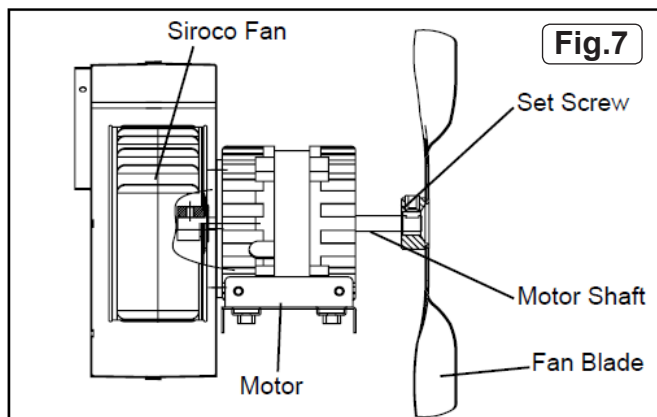

- 6.3.4. Spark Plug: Clean and re-gap after every 600 hours of operation, or replace as needed. After removing the spark plug, clean the terminals with a wire brush. Re-gap the terminals to 3.5mm (0.140") see fig.9.
- 6.3.5. Photocell: The photocell should be cleaned using a cotton swab dipped in alcohol or water at least once per heating season, or more depending on conditions, see fig.10.

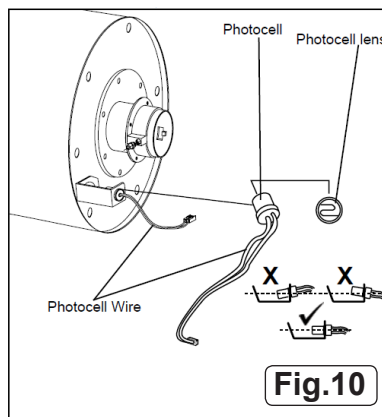
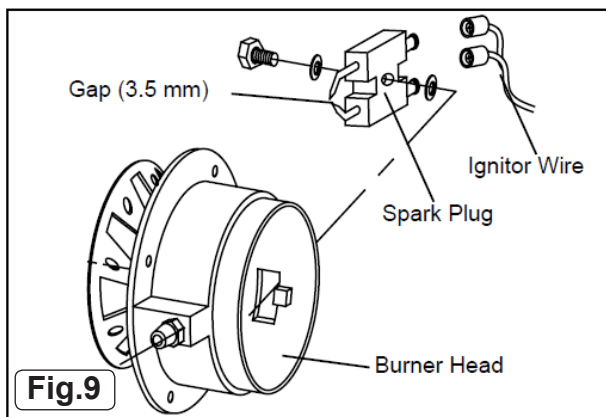

- 6.3.6. Nozzles: Nozzles should be cleaned or replaced at least once every heating season. Contaminated fuel could make this necessary immediately. To clean dirt from the nozzle, blow compressed air through the nozzle front. It may be necessary to soak the nozzle in kerosene to loosen any dirt particles, see fig.11.

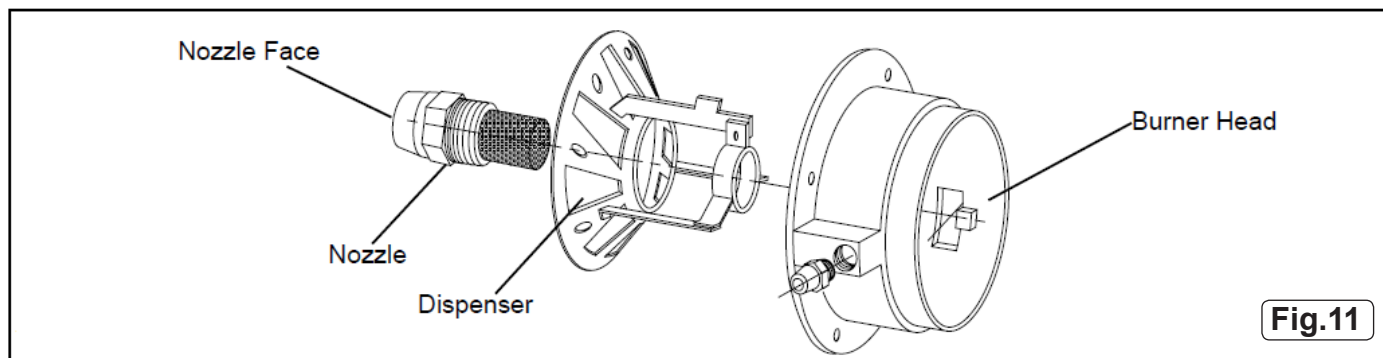

7. TROUBLESHOOTING

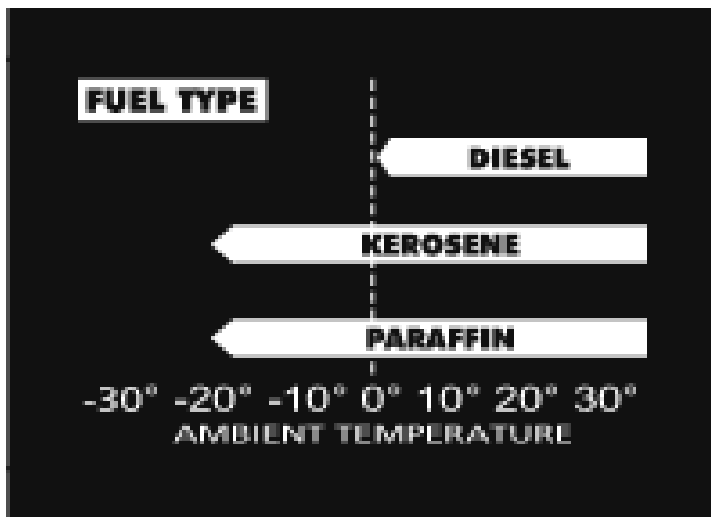

Although this heater operates with diesel fuel, when the temperatures are below 0°C, diesel additives are required to maintain the diesel's viscosity. Typically diesel can cloud in freezing conditions and will start to gel. You will need additives for your fuel in these conditions.

Kerosene/Paraffin does not start to gel until the ambient temperature is around -40°C.

Problem	Possible Cause	Solution
Heater Ignites, but main PCB shuts off after a short period of time. LED display shows "E1".	<ol style="list-style-type: none"> 1. Dirty input, output or lint filter. 2. Dirty fuel filter. 3. Nozzle is dirty. 4. Photocell lens is dirty. 5. Photocell not installed properly. 6. Photocell is defective. 7. Improper electrical connection between main PCB and photocell. 	<ol style="list-style-type: none"> 1. Clean / replace air or lint filter. 2. Clean / replace fuel filter. 3. Clean / replace Nozzle. 4. Clean / replace photocell. 5. Adjust photocell position 6. Replace photocell 7. Check wiring connections.
Heater will not operate or motor runs for a short time. LED display shows "E1".	<ol style="list-style-type: none"> 1. No kerosene in the fuel tank. 2. Corroded spark plug or incorrect plug gap. 3. Dirty fuel filter. 4. Dirty nozzle. 5. Moisture in fuel tank. 6. Improper electrical connection between transformer and circuit board. 7. Ignitor wire not connected to spark plug. 8. Defective ignitor. 	<ol style="list-style-type: none"> 1. Fill tank with fresh kerosene. 2. Clean / replace spark plug. 3. Clean / replace fuel filter. 4. Clean / replace nozzle. 5. Rinse fuel tank with clean, fresh kerosene. 6. Inspect all electrical connections. 7. Re-attach ignitor wire to spark plug. 8. Replace ignitor.
Fan does not operate when heater is plugged in and power switch is in the "ON" position. LED display shows "E1" or "E2".	<ol style="list-style-type: none"> 1. Thermostat is set too low. 2. Broken electrical connection between main PCB and motor. 	<ol style="list-style-type: none"> 1. Rotate thermostat to a higher setting 2. Inspect all electrical connections.
Poor combustion and / or excess soot production.	<ol style="list-style-type: none"> 1. Dirty input, output or lint filter. 2. Dirty fuel filter. 3. Poor quality of fuel. 4. PSI is too high or too low. 	<ol style="list-style-type: none"> 1. Clean / replace air or lint filter. 2. Clean / replace fuel filter. 3. Flush fuel tank and refuel heater. 4. Use proper pressure.
Heater does not turn on and the lamp is not lit.	<ol style="list-style-type: none"> 1. Temperature limit sensor has overheated. 2. No electrical power. 3. Fuse is blown. 4. Improper electrical connection between temperature limit sensor and circuit board. 	<ol style="list-style-type: none"> 1. Push power switch to "OFF" and allow heater to cool for 10 minutes. Restart heater. 2. Check power cords for proper connection and test the power supply. 3. Check / replace the fuse. 4. Inspect all electrical connections.



Parts support is available for this product. To obtain a parts listing and/or diagram, please log on to www.sealey.co.uk, email sales@sealey.co.uk or telephone 01284 757500.

Environmental Protection



Recycle unwanted materials instead of disposing of them as waste. All tools, accessories and packaging should be sorted, taken to a recycling centre and disposed of in a manner which is compatible with the environment.

When the product becomes completely unserviceable and requires disposal, drain off any fluids (if applicable) into approved containers and dispose of the product and the fluids according to local regulations.



WEEE Regulations

Dispose of this product at the end of its working life in compliance with the EU Directive on Waste Electrical and Electronic Equipment (WEEE). When the product is no longer required, it must be disposed of in an environmentally protective way. Contact your local solid waste authority for recycling information.

NOTE: It is our policy to continually improve products and as such we reserve the right to alter data, specifications and component parts without prior notice.

IMPORTANT: No liability is accepted for incorrect use of this product.

WARRANTY: Guarantee is 12 months from purchase date, proof of which will be required for any claim.



Sole UK Distributor, Sealey Group,
Kempson Way, Suffolk Business Park,
Bury St. Edmunds, Suffolk,
IP32 7AR



01284 757500



01284 703534



www.sealey.co.uk



sales@sealey.co.uk