

Thank you for purchasing a Sealey product. Manufactured to a high standard this product will, if used according to these instructions and properly maintained, give you years of trouble free performance.



IMPORTANT: READ THESE INSTRUCTIONS CAREFULLY. NOTE THE SAFE OPERATIONAL REQUIREMENTS, WARNINGS AND CAUTIONS. USE THIS JACK CORRECTLY AND WITH CARE FOR THE PURPOSE FOR WHICH IT IS INTENDED. FAILURE TO DO SO MAY CAUSE DAMAGE AND/OR PERSONAL INJURY AND WILL INVALIDATE THE WARRANTY. RETAIN THESE INSTRUCTIONS FOR FUTURE USE.

1. SAFETY PRECAUTIONS

- ✓ Ensure the jack is in sound condition and good working order. Take action for immediate repair or replacement of damaged parts. Use genuine parts only. The use of unauthorised parts may be dangerous and will invalidate the warranty.
- ✓ Locate the jack in a suitable, well lit work area.
- ✓ Keep work area clean and tidy and free from unrelated materials.
- ✓ Use jack on level and solid ground, preferably concrete. Avoid tarmac/adam as jack may sink in.
- ✓ Place wedges under wheels of vehicle (but ensure wheels of jack can move freely).
- ✓ Ensure the vehicle handbrake is engaged, engine is switched off and transmission is in 1st or reverse gear ("PARK" if automatic).
- ✓ Ensure minimum distance of 0.5m between vehicle and static objects such as doors, walls, etc., to allow for vehicle tilting.
- ✓ Ensure there are no passengers in the vehicle.
- ✓ Ensure all non-essential persons keep a safe distance whilst the jack is in use.
- ✓ Only place jack under those lifting points recommended by vehicle manufacturer (see vehicle handbook).
- ✓ Check the lifting point is stable and centred on the jack saddle.
- ✓ Ensure the jack wheels are free to move and that there are no obstructions.
- ❑ **DANGER:** Use the jack for lifting only, **NOT** for supporting the lifted load.
- ✓ Use suitable capacity axle stands under the vehicle before proceeding with any task.
- ✓ Ensure there are no persons or obstructions beneath the vehicle before lowering.
- ✓ Use a qualified person to maintain or repair the jack hydraulic system.
- ✗ **DO NOT** operate the jack if damaged.
- ✗ **DO NOT** allow untrained persons to operate the jack.
- ✗ **DO NOT** exceed the rated capacity of the jack.
- ✗ **DO NOT** allow the vehicle to move while supported by the jack, nor use the jack to move the vehicle.
- ✗ **DO NOT** jack vehicle if there is a risk of spillage of fuel, battery acid, or other dangerous substance.
- ✗ **DO NOT** work under the vehicle until axle stands have been correctly positioned.
- ✗ **DO NOT** use the jack for purposes other than that for which it is designed.
- ✗ **DO NOT** top up hydraulic system with brake fluid. Use hydraulic jack oil only.

2. SPECIFICATIONS

Model	5100
Capacity	5tonne
Min. Saddle Height	150mm
Max. Saddle Height	570mm
Max. Chassis Height	200mm
Length.....	1410mm
Weight	102kg

3. ASSEMBLY & PURGING

- 3.1. Fit the handle assembly into the handle socket with the valve control lever towards the jack. Retain with the handle fixing bolt. See fig.1.
- 3.2. Before using the jack for the first time, purge the hydraulic circuit in order to eliminate any air in the system. To do this, open the release valve by moving the lever downwards from position A to position B as shown in fig.2. In the lower position B the handle must engage with one of the 3 handle locations indicated in fig.1. Once engaged the release valve can be opened by rotating the lever fully sideways as shown in fig.2-C. Pump the foot pedal through its full travel 6 or 7 times.

- 3.3. Return the release valve lever to the upper closed position (see fig.2-A)
- 3.3. Place a few drops of hydraulic jack oil on the pump piston and pump the handle several times to distribute the oil. Thoroughly lubricate all moving parts.

4. OPERATING INSTRUCTIONS

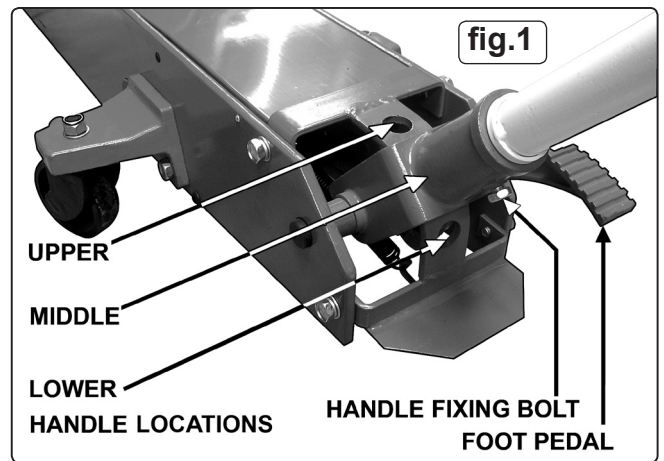

- 4.1. **General jacking.**
 - ❑ **WARNING! Before lifting, ensure Section 1 safety instructions are strictly followed.**
 - 4.1.1. Prepare vehicle as described in safety instructions ensuring the ground on which jack is to stand is level and solid (not tarmac/adam). We recommend concrete.
 - 4.1.2. Position the jack saddle under the vehicle manufacturer's recommended lifting point (see vehicle handbook).
- 4.2. **Jacking the vehicle.**
 - 4.2.1. Ensure that the release valve lever is in the upper closed position, see fig.2A. The jack saddle may be raised quickly up to the load using the foot pedal. **DO NOT** attempt to raise the load with the foot pedal.
 - 4.2.2. Commence pumping the handle up and down through its full stroke until the vehicle reaches the required height.
- Note:** If the jack becomes overloaded, the safety valve will operate and prevent the jack from lifting further.
- 4.3. **Lowering the vehicle.**
 - 4.3.1. To lower the vehicle, open the release valve by moving the lever downwards from position A to position B as shown in fig.2. In the lower position B the handle must engage with one of the 3 handle locations indicated in fig.1. Once engaged the release valve can be opened by rotating the lever fully sideways as shown in fig.2-C.
- ❑ **SAFETY WARNING! Always lower in a slow and controlled manner and ensure that there are no persons or obstacles beneath the vehicle, or in the path of descent.**

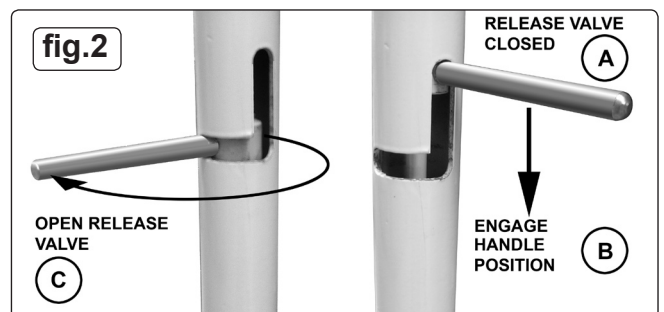

5. MAINTENANCE

IMPORTANT: Only fully qualified personnel should attempt maintenance or repair.

- 5.1. When the jack is not in use, the ram should be in the lowest position to minimise corrosion. Remove the handle to inactivate the jack.
- 5.2. Keep the jack clean and lubricate all moving parts with oil on a regular basis.
- 5.3. Every 3 months grease the lifting arm pivot pin and the rear castors via the grease nipples provided.
- 5.4. The pump and cylinder form a closed hydraulic system and refilling with oil is only necessary in exceptional cases. To check oil level:
 - 1) Place jack on a level surface with the saddle fully lowered.
 - 2) Remove the 4 top cover retaining screws and lift off the cover.
 - 3) The oil is topped up via the rubber bung which is situated on top of the cylinder nearest to the ram end of the pump.

NOTE: Use a good quality jack oil, such as SEALEY HYDRAULIC JACK OIL.

- ☐ **WARNING: DO NOT use brake fluid, or any fluid other than hydraulic jack fluid as this will cause serious damage to the jack and will invalidate the warranty!**
- 5.5. Before each use check for broken, cracked, bent, or loose parts, or any visible damage to ram, pump, saddle, lifting arm, frame and all parts including nuts, bolts, pins and other fasteners. If any suspect item is found, remove jack from service and take the necessary action to remedy the problem.
DO NOT use the jack if it is believed to have been subjected to abnormal or shock loading. Inspect and take appropriate action.
 - 5.6. Periodically check the pump piston and the ram for signs of corrosion. Clean exposed areas with a clean cloth and jack oil.

IMPORTANT: NO RESPONSIBILITY IS ACCEPTED FOR INCORRECT USE OF THIS PRODUCT.

- 5.7. **De-commissioning.**
Should the jack become completely unserviceable, draw off the oil into an approved container and dispose of the jack and the oil according to local regulations.

Hydraulic products are repaired by local service agents only. we have service/repair agents in all parts of the UK.

DO NOT return jacks to us. Please telephone us on 01284 757500 to obtain the address and telephone number of your local agent. If jack is under guarantee you can also contact your local dealer.



6. TROUBLESHOOTING

PROBLEM	POSSIBLE CAUSE	REMEDY
Jack will not lift the load properly or will not hold raised load.	1) Overloaded 2) Release valve not closed 3) Air in system 4) Low oil level 5) Internal defect	1) Be sure to use jack with adequate capacity. 2) Check and close release valve. 3) Purge system as described in section 3.2. 4) Check level and replenish if necessary. 5) Contact Service Agent.
Jack will not lower	1) Unit requires lubrication 2) Piston rod bent or damaged 3) Jack frame/link system distorted due to overloading/poor positioning 4) Air in system 5) Release valve partially closed 6) Release valve blocked	1) Oil all external moving parts. 2) Contact local Service Agent. 3) Replace damaged parts or contact Service Agent. 4) Purge system as described in section 3.2 5) Check and fully open release valve. 6) Clean release valve.

NOTE: It is our policy to continually improve products and as such we reserve the right to alter data, specifications and component parts without prior notice.

IMPORTANT: No liability is accepted for incorrect use of this product.

WARRANTY: Guarantee is 12 months from purchase date, proof of which will be required for any claim.

INFORMATION: For a copy of our latest catalogue and promotions call us on 01284 757525 and leave your full name and address, including postcode.



Sole UK Distributor, Sealey Group,
Kempson Way, Suffolk Business Park,
Bury St. Edmunds, Suffolk,
IP32 7AR

☎ 01284 757500
🖨 01284 703534

🌐 www.sealey.co.uk
✉ sales@sealey.co.uk