

Thank you for purchasing a Sealey product. Manufactured to a high standard, this product will, if used according to these instructions and maintained properly, give you years of trouble free performance.

IMPORTANT: PLEASE READ THESE INSTRUCTIONS CAREFULLY. NOTE THE SAFE OPERATIONAL REQUIREMENTS, WARNINGS & CAUTIONS. USE THE PRODUCT CORRECTLY AND WITH CARE FOR THE PURPOSE FOR WHICH IT IS INTENDED. FAILURE TO DO SO MAY CAUSE DAMAGE AND/OR PERSONAL INJURY AND WILL INVALIDATE THE WARRANTY. KEEP THESE INSTRUCTIONS SAFE FOR FUTURE USE.



Refer to instruction manual



Wear safety footwear

1. SAFETY

- ✓ Ensure the jack is in sound condition and good working order. Take action for immediate repair or replacement of damaged parts. Use genuine parts only. The use of improper parts may be dangerous and will invalidate the warranty.
- ✓ Locate the jack in a suitable, well lit working area.
- ✓ Keep working area clean and tidy and free from unrelated materials.
- ✓ Use jack on level and solid ground, preferably concrete.
- ✓ Avoid tarmac as jack may sink in. Chock wheels of vehicle.
- ✓ Ensure the vehicle handbrake is engaged, engine is switched off and transmission is in gear (or "PARK" if automatic).
- ✓ Ensure minimum distance of 0.5m between vehicle and static objects such as doors, walls, etc., to allow for vehicle tilting.
- ✓ Ensure all non-essential persons keep a safe distance whilst the jack is in use.
- ✓ Ensure there are no passengers in the vehicle.
- ✓ Place jack under only those lifting points recommended by vehicle manufacturer (see vehicle handbook).
- ✓ Check that the lifting point is stable and centred on the jack saddle.
- ✓ Ensure the jack wheels are free to move and that there are no obstructions.
- ▲ **DANGER:** Use the jack for lifting only, **NOT** for supporting the lifted load.
- ✓ Ensure there are no persons or obstructions beneath the vehicle before lowering.
- ✓ Use suitable axle stands under the vehicle before proceeding with any task.
- ✓ Use a qualified person to lubricate and maintain the jack.
- ✓ Ensure that only hydraulic jack oil is used in the jack.
- ✗ **DO NOT** operate the jack if damaged.
- ✗ **DO NOT** allow untrained persons to operate the jack.
- ✗ **DO NOT** exceed the rated capacity of the jack.
- ✗ **DO NOT** allow the vehicle to move during lifting or lowering, or use the jack to move the vehicle.
- ✗ **DO NOT** jack vehicle if there is a risk of spillage of fuel, battery acid, or other dangerous substances.
- ✗ **DO NOT** work under the vehicle until appropriately rated axle stands have been correctly positioned.
- ✗ **DO NOT** use the jack for purposes other than that for which it is intended.
- ✗ **DO NOT** top up hydraulic system with brake fluid. Use hydraulic jack oil only.
- ✗ **DO NOT** adjust the safety overload valve.
- ✓ When not in use store jack, fully lowered, in a safe, dry, childproof area.

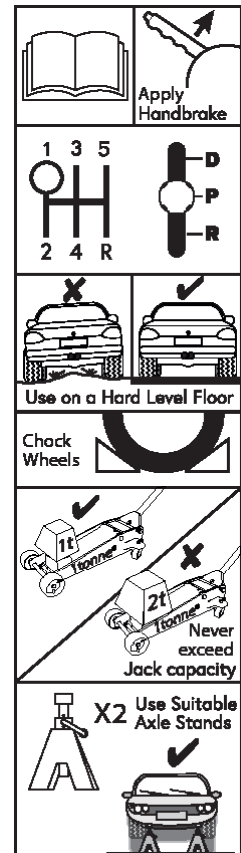

2. INTRODUCTION

Single piece hydraulic unit with heavy base design and large jacking saddle. Universal joint release mechanism allows safer, more controlled Lowering of the jack. Rocket Lift feature brings lifting arm into contact with jacking point with just minimal pumps. Polyurethane wheels for Smoother manoeuvrability and helps prevent damage to workshop floor. Protective jack handle sleeve helps prevent accidental damage to car Bodywork when pumping the handle. The Anniversary Edition range is available in three colours, for ease of location and visual safety.

3. SPECIFICATION

Model Nos:.....	4040 SERIES
Capacity	4tonne
Minimum saddle height	100mm
Maximum saddle height	533mm
Maximum chassis height.....	162mm
Length.....	745mm
Weight.....	44kg

4. ASSEMBLY

- 4.1. Insert the upper handle into the lower handle. Secure the two pieces together with the bolts (Fig.1.A).
- 4.2. Undo the handle socket screw (B) until it no longer protrudes into the handle socket (Fig.2).
- 4.3. Insert the pump handle into the handle socket, engaging the square drive of the release valve.
- 4.4. Ensure that the handle is correctly inserted into the socket, then tighten the handle socket screw (B).

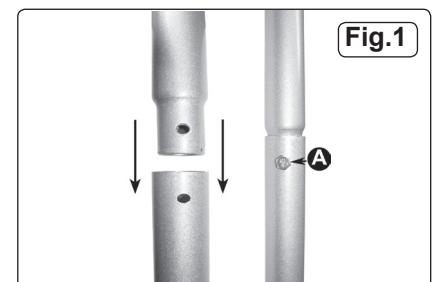

5. HYDRAULIC SYSTEM PURGING

- 5.1. Open the release valve by turning it one full turn counter-clockwise.
- 5.2. Pump the handle a minimum eight full strokes.
- 5.3. Close the release valve by turning it clockwise.

6. OPERATION

- ❑ **WARNING!** Before use ensure you have read, understood and applied Section 1 safety precautions.

IMPORTANT: Before use, the operator is to visually inspect the jack for cracked welds, damaged or missing parts or hydraulic leaks.

6.1. RAISING A VEHICLE

We recommend that efforts of raising the load shall be reduced by the use of assistance during this operation.

- 6.2. Ensure that the jack and the vehicle are on a hard, level surface.
- 6.2.1. Always ensure that the vehicle handbrake is engaged and that the vehicle wheels are chocked.
- 6.2.2. Consult the vehicle manual to determine the location of jacking points.
- 6.2.3. Position the jack under a suitable lifting point.
- 6.2.4. Turn the release valve clockwise, to the closed position (Fig.3).

DO NOT over-tighten.

- 6.2.5. Raise the vehicle to the desired height by pumping the handle up and down.
- 6.2.6. Place axle stands beneath the locations recommended by the vehicle manufacturer.
- 6.2.7. Turn the release valve slowly counter-clockwise to lower the vehicle on to the axle stands.

6.3. LOWERING A VEHICLE

- 6.4. Turn the release valve clockwise to the closed position.
- 6.4.1. Pump the handle to raise the vehicle off the axle stands.
- 6.4.2. Remove the axle stands from beneath the vehicle.
- 6.4.3. Turn the release valve slowly counter-clockwise to lower the vehicle to the ground.

NOTE: When not in use, ALWAYS leave the saddle and ram fully retracted.

7. MAINTENANCE

IMPORTANT: Only fully qualified personnel should attempt maintenance or repair.

7.1. MONTHLY MAINTENANCE

Lubrication is critical to jacks. Any restriction due to dirt or rust can cause either slow or extremely rapid jack movement, causing damage to the internal components.

To keep the jack well lubricated, carry out the following steps.

- 7.1.1. Lubricate the ram, the linkages and the saddle and pump mechanism with light oil.
- 7.1.2. Grease the wheel bearings and axles.
- 7.1.3. Keep all jack surfaces and warning labels clean.
- 7.1.4. Check and maintain the ram oil level (Section 7.3).

7.2. THREE MONTHLY MAINTENANCE

- 7.2.1. At three monthly intervals, check the ram for any signs of rust or corrosion. Clean the ram as required and wipe with an oiled cloth.

7.3. CHECKING THE OIL LEVEL

- 7.3.1. Fully retract the ram by turning the release valve counter-clockwise.
- 7.3.2. With the jack in the level position, remove the oil filler plug (Fig.4).
- 7.3.3. The oil should be level with the bottom of the oil filler hole. If it is not, top up with clean hydraulic jack oil.
- 7.3.4. Replace the oil filler plug and check the jack operation.
- 7.3.5. Purge air from the hydraulic unit as required. Refer to Section 5.

NOTE: Always store the jack in the fully lowered position. This will protect critical areas from excessive corrosion.

Owing to their size and weight, hydraulic products should ideally be repaired by local service agents. We have service / repair agents in most parts of the UK. Before returning your product please call our technical helpline on **01284 757505** for advice and troubleshooting guidance. *If the jack is under guarantee please contact your stockist.*

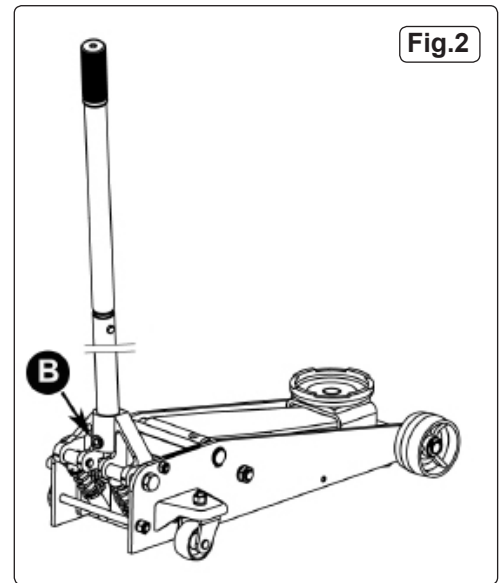

Fig.2

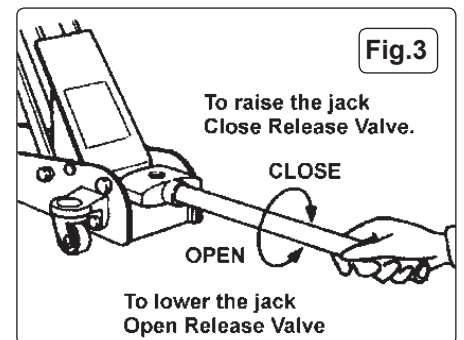

Fig.3

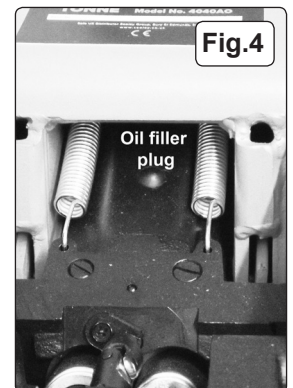

Fig.4