



METAL CUTTING SHEARS

MODEL NO: **3S/4R.V3, 3S/5R.V3, 3S/6R.V3**

Thank you for purchasing a Sealey product. Manufactured to a high standard, this product will, if used according to these instructions, and properly maintained, give you years of trouble free performance.

IMPORTANT: PLEASE READ THESE INSTRUCTIONS CAREFULLY. NOTE THE SAFE OPERATIONAL REQUIREMENTS, WARNINGS & CAUTIONS. USE THE PRODUCT CORRECTLY AND WITH CARE FOR THE PURPOSE FOR WHICH IT IS INTENDED. FAILURE TO DO SO MAY CAUSE DAMAGE AND/OR PERSONAL INJURY AND WILL INVALIDATE THE WARRANTY. KEEP THESE INSTRUCTIONS SAFE FOR FUTURE USE.



Refer to instructions



Wear eye protection



Wear protective gloves

1. SAFETY

- ✓ Ensure that the shears are securely mounted on a rigid work surface surrounded by sufficient free area to manipulate the workpiece easily and safely.
- ✓ Always wear suitable Personal Protective Equipment to guard against injury. Protective goggles and gloves are available from your Sealey Stockist. Non slip footwear should be worn.
- ✓ Make sure that the work area is well lit and is kept tidy. The floor should be dry and clean.
- ✗ **DO NOT** allow fingers or hands to come into close proximity to the cutting wheels and beware of sharp edges and swarf.
- ✗ **DO NOT** use this product if tired or under the influence of alcohol or drugs.
- ✓ Keep children well away from this product at all times.

2. INTRODUCTION

Manufactured from steel-plate and fitted with hardened steel shear blades for accurate cutting and long life. Designed to be bolted to the bench. Suitable for cropping steel sheet and bar.

3. SPECIFICATION

Model No:.....	3S/4R.V3	3S/5R.V3	3S/6R.V3
Maximum Cut Length:.....	105mm	135mm	175mm
Round Bar:.....	Ø10mm*	Ø11mm*	Ø12mm*
Sheet:.....	4mm*	5mm*	6mm*

Note: *Capacity in Steel

4. ASSEMBLY

- 4.1. Securely bolt the body of the shear to a strong work surface at a comfortable height.
- 4.2. Connect both parts of the handle together and attach it to the body.

5. OPERATION

- ✓ Ensure that the shears are securely mounted on a rigid work surface surrounded by sufficient free area to manipulate the workpiece easily and safely.
 - ✗ **DO NOT** force this machine to cut metals beyond its specified range.
- 5.1. **CUTTING FLAT METAL**
 - 5.1.1. Scribe a line on the metal to be cut.
 - 5.1.2. Line up scribe mark with jaws and pull handle.
 - 5.1.3. If required, use the adjustable support rod to stop metal from deforming while cutting.
 - 5.1.4. Extend the handle for the thicker metals.
 - 5.1.5. When cutting a sheet of metal, take small cuts and feed the sheet into the jaws being careful to keep your fingers clear of the jaws. If the sheet of metal is awkward make sure you have assistance.
 - 5.2. **CUTTING ROUND BAR**
 - 5.2.1. Round bar can be cut using the bar cutting hole in the blade.

6. MAINTENANCE

- 6.1. Lightly oil moving components.

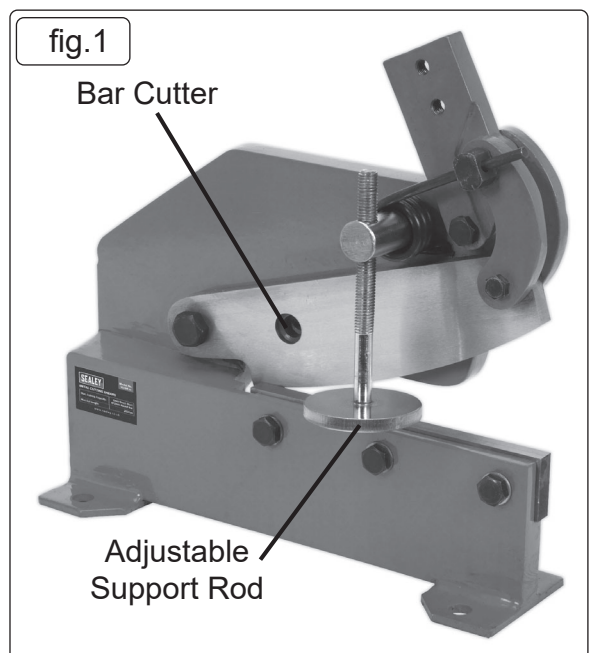



ENVIRONMENT PROTECTION

Recycle unwanted materials instead of disposing of them as waste. All tools, accessories and packaging should be sorted, taken to a recycling centre and disposed of in a manner which is compatible with the environment. When the product becomes completely unserviceable and requires disposal, drain any fluids (if applicable) into approved containers and dispose of the product and fluids according to local regulations.

Note: It is our policy to continually improve products and as such we reserve the right to alter data, specifications and component parts without prior notice. Please note that other versions of this product are available. If you require documentation for alternative versions, please email or call our technical team on technical@sealey.co.uk or 01284 757505.

Important: No Liability is accepted for incorrect use of this product.

Warranty: Guarantee is 12 months from purchase date, proof of which is required for any claim.

Sealey Group, Kempson Way, Suffolk Business Park, Bury St Edmunds, Suffolk. IP32 7AR



01284 757500



01284 703534



sales@sealey.co.uk



www.sealey.co.uk