



TROLLEY JACK 3 TONNE WITH FOOT PEDAL

MODEL NO: **3001CXP**

Thank you for purchasing a Sealey product. Manufactured to a high standard, this product will, if used according to these instructions, and properly maintained, give you years of trouble free performance.

IMPORTANT: PLEASE READ THESE INSTRUCTIONS CAREFULLY. NOTE THE SAFE OPERATIONAL REQUIREMENTS, WARNINGS & CAUTIONS. USE THE PRODUCT CORRECTLY AND WITH CARE FOR THE PURPOSE FOR WHICH IT IS INTENDED. FAILURE TO DO SO MAY CAUSE DAMAGE AND/OR PERSONAL INJURY AND WILL INVALIDATE THE WARRANTY. KEEP THESE INSTRUCTIONS SAFE FOR FUTURE USE.



Refer to instructions



Wear safety footwear

1. SAFETY

- ❑ **WARNING! ALWAYS USE AXLE STANDS**
- ❑ **WARNING!** Please note that the handle socket of this jack is retained under tension and must be released before use. Caution should be taken when releasing, as the handle socket will suddenly raise to its upright position if not controlled. **See 4.1 for instructions on how to release the retaining clip.**
- ✓ Please remember a trolley jack is a lifting device and is not designed to support a load. Never get underneath a vehicle supported only by a jack - your life is at risk. We stock a comprehensive range of axle stands - please see relative section for full details.
- ✓ Ensure the jack is in sound condition and good working order. Take action for immediate repair or replacement of damaged parts. Use genuine parts only. The use of improper parts may be dangerous and will invalidate the warranty.
- ✓ Locate the jack in a suitable, well lit working area. Keep working area clean and tidy and free from unrelated materials.
- ✓ Use jack on level/solid ground, preferably concrete. Avoid tarmac/adam as jack may sink in.
- ✓ Place wedges under wheels of vehicle, but ensure the jack wheels are free to move and that there are no obstructions.
- ✓ Ensure the vehicle handbrake is engaged, engine is switched off and transmission is in gear (or "PARK" if automatic).
- ✓ Ensure minimum distance of 0.5m between vehicle and static objects such as doors, walls, etc., to allow for vehicle tilting.
- ✓ Ensure there are no passengers in the vehicle and that all non-essential persons keep a safe distance whilst the jack is in use.
- ✓ Place jack under lifting points recommended by vehicle manufacturer (see vehicle hand book). Ensure lifting point is stable and centred on saddle.
- ▲ **DANGER:** Use the jack for lifting only, NOT for supporting the lifted load.
- ✓ Use suitable capacity axle stands under the vehicle before proceeding with any task.
- ✓ Ensure there are no persons or obstructions beneath the vehicle before lowering.
- ✗ **DO NOT** operate the jack if damaged.
- ✗ **DO NOT** work under the vehicle until axle stands have been correctly positioned.
- ✗ **DO NOT** exceed the rated capacity of the jack (3tonne/3000kg). When lifting a load of maximum capacity or close to it, it is recommended that the effort be reduced by the use of assistance during this operation.
- ✗ **DO NOT** adjust the safety overload valve.
- ✗ **DO NOT** jack vehicle if there is a risk of spillage of fuel, battery acid, or other dangerous substances.
- ✗ **DO NOT** allow the vehicle to move while supported by the jack, or use the jack to move the vehicle.
- ✗ **DO NOT** top up hydraulic system with brake fluid. Use hydraulic jack oil only and use a qualified person to maintain jack hydraulic system.
- ✗ **DO NOT** allow untrained persons to operate the jack.
- ✗ **DO NOT** use jack for purposes other than which it is designed.
- ✗ **DO NOT** allow persons to ride on the jack.
- ✓ When not in use store jack, fully lowered, in a safe, dry, childproof area.

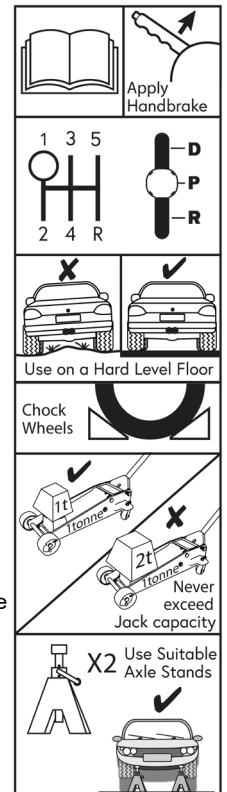

2. INTRODUCTION

Single-piece hydraulic unit with heavy base design. Foot pedal as fast lifting alternative method of raising saddle, especially useful in restricted spaces. Universal joint release mechanism and long 2-piece handle. Heavy-duty castors and extra-large saddle design ease positioning under vehicle. Fitted with safety overload valve and pump-through valve to prevent handle locking at maximum ram extension. Ideal for loaded vans up to 3.5 Tonne GVW.



3. SPECIFICATION

Model No:..... 3001CXP
Capacity:..... 3tonne
Consumable Parts:.....Optional Rubber Jack Pad - JP17
Length:..... 703mm

Maximum Chassis Height: 255mm
Maximum Saddle Height: 460mm
Minimum Saddle Height: 117mm

4. OPERATION

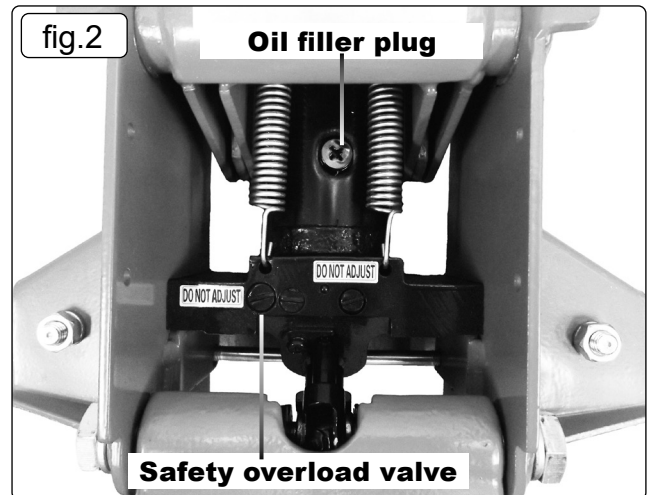
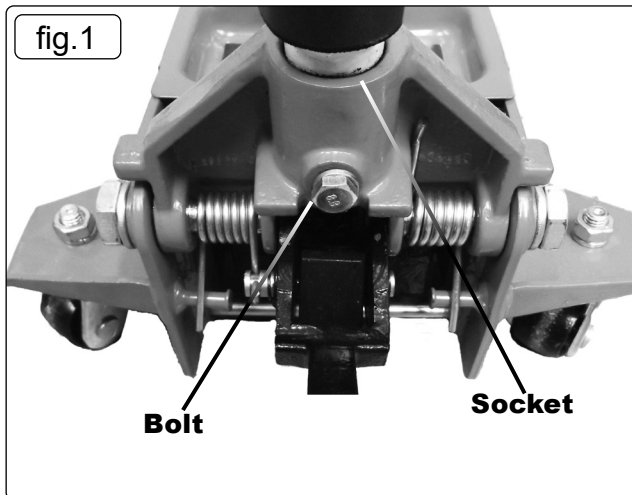

4.1. RELEASING THE RETAINING CLIP

- 4.1.1. Seek assistance from a second person if required.
- 4.1.2. Insert the lower handle section into the handle socket to aid in releasing pressure in the handle socket.
- 4.1.3. Push down on the handle and hold down while unscrewing the handle retaining bolt that is securing the handle socket in the down position.
- 4.1.4. Remove the clip from the bolt and the lower chassis bar.
- 4.1.5. Gently and in a controlled manner slowly allow the lower handle section and handle socket to raise to their upright position.
- 4.1.6. Replace the handle retaining bolt to secure the handle in the socket.

4.2. BEFORE FIRST USE

- 4.2.1. Assemble handle by sliding the two parts together and rotating until the locking pin clicks into position. Partially unscrew bolt on the handle socket (fig.1), slide handle in and tighten the bolt to lock handle in place.
- 4.2.2. Before using jack for the first time, purge the hydraulic unit in order to eliminate any air in the system. Turn handle anti clockwise to open release valve.
- 4.2.3. Pump for 30 to 40 seconds. When complete, close the release valve by turning the handle clockwise.
- 4.2.4. Place a few drops of hydraulic jack oil on pump piston and pump handle several times to distribute oil. Thoroughly lubricate moving parts.

4.3. GENERAL JACKING

- WARNING!** Before lifting ensure Safety instructions are read and understood.

- 4.3.1. Position the jack saddle under the vehicle manufacturer's recommended lifting point.

4.4. JACKING THE VEHICLE

- 4.4.1. Rotate handle clockwise to close the release valve.
- 4.4.2. Commence pumping handle up and down using maximum strokes until the jack saddle reaches the vehicle manufactures jacking point. Check the jacking point is centrally located on the saddle and raise the vehicle.
- 4.4.3. Should the jack become overloaded, a safety excess pressure valve will open, and stop the vehicle from lifting.

- WARNING!** The jack is a lifting device only and must not be used to support the load. Use correctly rated axle stands to support the load.

4.5. LOWERING THE VEHICLE

- 4.5.1. If using axle stands, raise the jack high enough for the stands to be easily removed. Then turn handle anticlockwise very slowly to open the valve.
- 4.5.2. The lowering speed is controlled by the amount you turn the handle. Lower carefully, avoid any sudden changes in descent rate which would shock load the hydraulic system.

- WARNING!** Ensure there are no persons or obstacles beneath the vehicle, or in the path of its descent.

5. MAINTENANCE

- 5.1. When the jack is not in use, the ram should be in its lowest position to minimise corrosion. Remove the handle to inactivate jack.
- 5.2. Keep the jack clean and lubricate all moving parts with oil on a regular basis.
- 5.3. Before each use check for broken, cracked, bent, or loose parts, or any visible damage to ram, pump, saddle, lifting arm, frame and all parts including nuts, bolts, pins and other fasteners. If any suspect item is found remove jack from service and take necessary action to remedy the problem.
- 5.4. **DO NOT** use the jack if believed to have been subjected to abnormal load or shock load.
- 5.4. Periodically check the pump piston and the ram for signs of corrosion. Clean exposed areas with a clean oiled cloth.
- 5.5. After one year the oil should be replaced in order to extend the life of the jack. Use hydraulic jack oil only.
- 5.6. **WARNING!** Only competent personnel should attempt hydraulic maintenance or repair.
- 5.6. To check the oil level, fully lower the jack and remove filler screw (fig.2). The correct level is the bottom of the screw hole. If oil level is low, fill as required. Pump jack 5 or 6 times to expel air. Pump jack up to full height and pour off excess oil before refitting plug.
- 5.6. **DO NOT** touch the safety overload valve (fig.2).

NOTE: Use Sealey quality hydraulic jack oil, Model No.s HJO500MLS / HJO5LS to top up or replace the hydraulic fluid.

- ❑ **WARNING: DO NOT** use brake fluid, or any fluid other than hydraulic jack oil as this may cause serious damage to the jack and will invalidate the warranty.

5.7. To drain the oil, remove the filler screw and raise front of jack. Make sure that no dirt is allowed to enter the hydraulic system.

IMPORTANT: NO RESPONSIBILITY IS ACCEPTED FOR INCORRECT USE OF PRODUCT.

Hydraulic products are only repaired by local service agents. We have service/repair agents in all parts of the UK.

- ✖ **DO NOT** return jacks to us. Please telephone us on 01284 757500 to obtain the address and 'phone number of your local agent. If jack is under guarantee contact your local Sealey Stockist.

5.8. DE-COMMISSIONING THE JACK

Should the jack become completely unserviceable and require disposal, draw off the oil into an approved container and dispose of the jack and the oil according to local regulations.

6. TROUBLESHOOTING

PROBLEM	POSSIBLE CAUSE	REMEDY
Jack will not lift the load	1) Overloaded 2) Oil level low 3) Release valve not correctly closed 4) Air in system 5) Piston rod not functioning 6) Packing worn or defective	1) Be sure to use jack with adequate capacity 2) Top up oil level 3) Check and close release valve 4) Open release valve and pump the handle a few times. Close valve and re-try 5) Clean and replace oil 6) Replace packing
Jack does not lift high enough Or feels "spongy"	1) Oil level too high or too low 2) Worn seals 3) Air in system 4) Release valve not closed	1) Fill or remove excess oil 2) Return jack to local service agent 3) Open release valve and pump the handle a few times. Close valve and re-try 4) Check and close release valve
Jack lifts poorly	1) Pump packing or valves malfunctioning 2) Oil is dirty 3) Air in the system	1) Replace packing and/or clean valves 2) Replace oil 3) Open release valve and pump the handle a few times. Close valve and re-try
Jack lifts but will not hold load	1) Release valve partially open 2) Dirt on valve seats 3) Air in system 4) Faulty seals 5) Packing worn or defective	1) Check and close release valve 2) Lower jack, close release valve. Place foot on front wheel and pull up lifting arm to it's full height by hand. Open the release valve to lower arm 3) Open release valve and pump the handle a few times. Close valve and re-try 4) Replace packing or contact local service agent 5) Replace packing
Jack will not lower completely	1) Unit requires lubrication 2) Piston rod bent or damaged 3) Jack frame/link system distorted due to overloading/poor positioning 4) Air in system 5) Release valve partially closed 6) Jack spring damaged or unhooked.	1) Oil all external moving parts 2) Replace rod or contact local service agent 3) Replace damaged parts or contact local service agent 4) Open release valve and pump the handle a few times. Close valve and re-try 5) Check and fully open release valve 6) Replace spring or contact local service agent
Jack does not lower at all	1) Release valve closed	1) Check and fully open release valve



ENVIRONMENT PROTECTION

Recycle unwanted materials instead of disposing of them as waste. All tools, accessories and packaging should be sorted, taken to a recycling centre and disposed of in a manner which is compatible with the environment. When the product becomes completely unserviceable and requires disposal, drain any fluids (if applicable) into approved containers and dispose of the product and fluids according to local regulations.



REGISTER YOUR
PURCHASE HERE

Note: It is our policy to continually improve products and as such we reserve the right to alter data, specifications and component parts without prior notice.

Important: No Liability is accepted for incorrect use of this product.

Warranty: Guarantee is 12 months from purchase date, proof of which is required for any claim.

Sealey Group, Kempson Way, Suffolk Business Park, Bury St Edmunds, Suffolk. IP32 7AR



01284 757500



01284 703534



sales@sealey.co.uk



www.sealey.co.uk